

PART PLAN

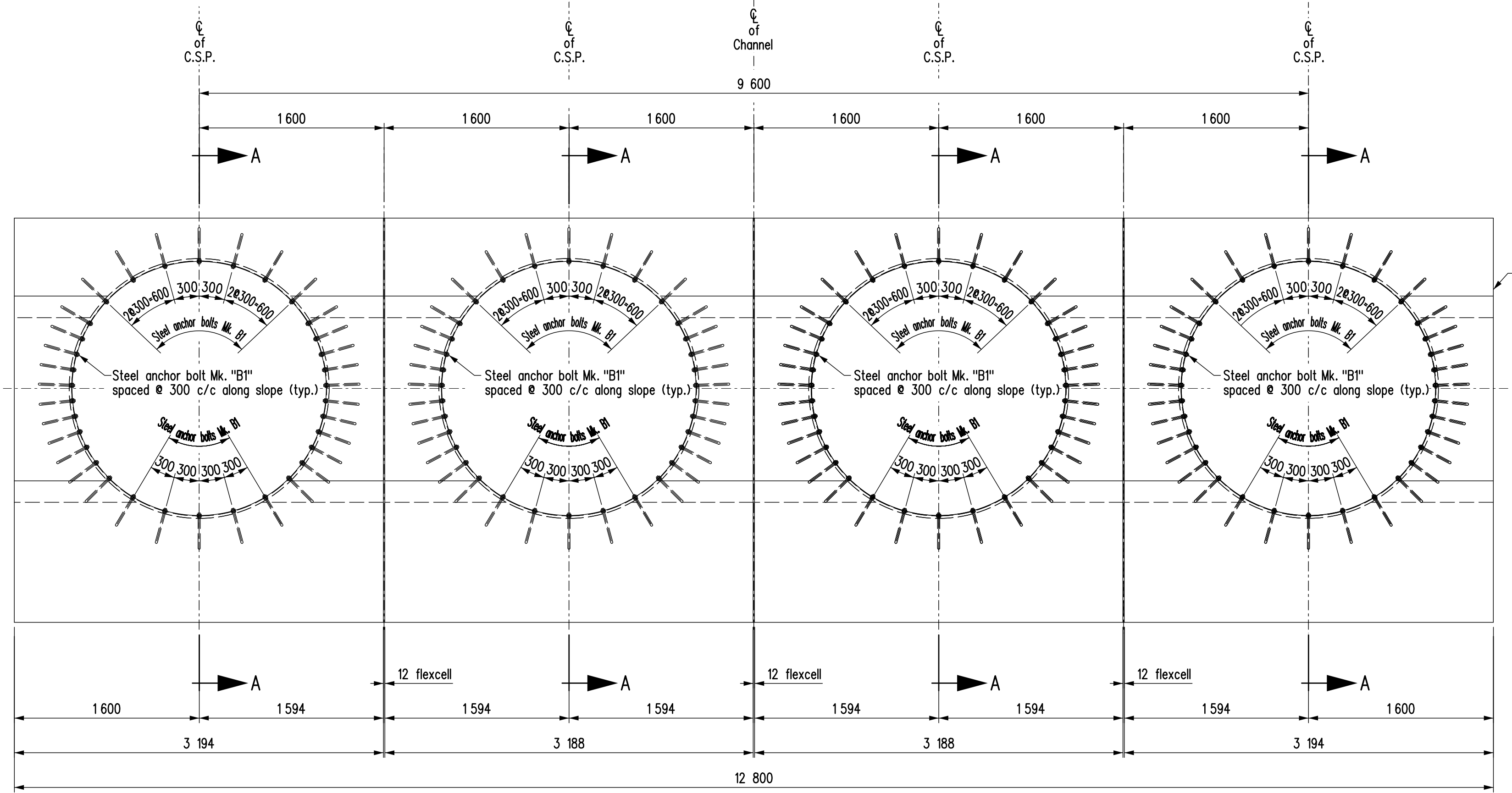

ELEVATION

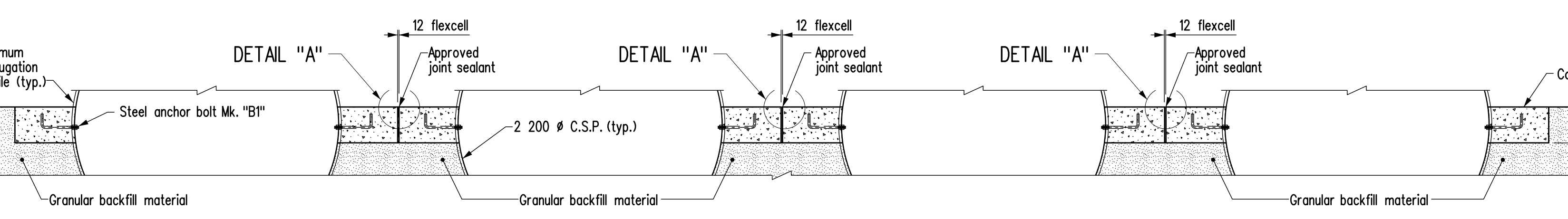

SECTION B-B

NOTES:

1. Pour panels independently with 12 mm flexcell joint as shown or alternately cast the panels monolithically and use joint detail as shown in the Alternate Joint Detail "A". With either method of construction seal the joint(s) with an approved joint sealant.
2. All exposed surfaces of concrete headwalls to be permeable formwork liner finish.
3. All exposed edges of headwalls to be chamfered 25 mm except where noted otherwise.
4. 2 200 mm ϕ Corrugated Steel Pipe (CSP) end treatment assumed to have 2:1 beveled ends with 300 mm top and bottom steps. Also known as "standard slope" ends.
5. Assumed maximum 25 mm corrugation depth.
6. This standard is for culverts designed for a zero degree skew. A maximum of 15 degree skew is permissible provided that:
 - The headwall is constructed perpendicular to the axis of the culvert and
 - The roadway sideslope is modified (widening and flattening of the slope at the obtuse corners) to accommodate the headwall geometry.

DESIGN DATA

SPECIFICATIONS
AASHTO LRFD BRIDGE DESIGN SPECIFICATIONS, SEVENTH EDITION, 2014

STRUCTURAL CONCRETE

COMPRESSIVE STRENGTH $f_c = 35 \text{ MPa}$
 CEMENT CSA A23.1, CLASS C-1
 EXPOSURE CLASS AIR CATEGORY 1
 REINFORCING STEEL CAN/CSA G30.18-M92 GRADE 400W
 CLEAR COVER 50 mm (UNLESS NOTED OTHERWISE)

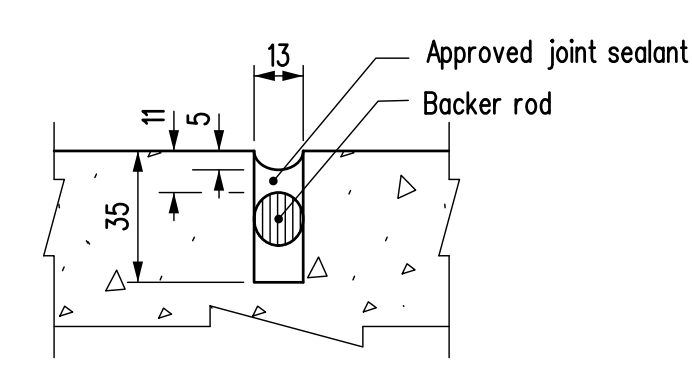

ALTERNATE JOINT DETAIL "A"

Centered between C.S.P.'S
Scale 1:2

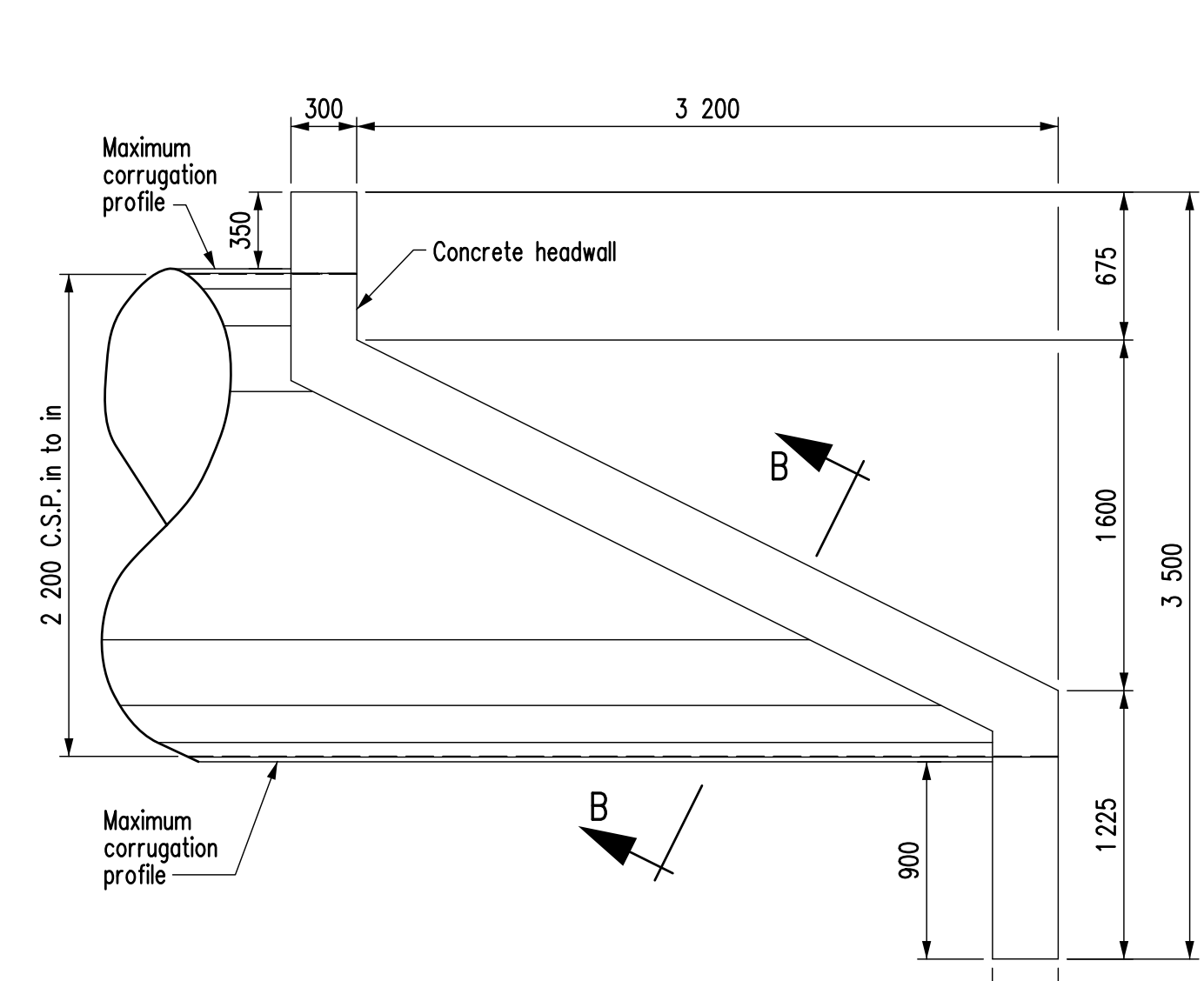

SIDE ELEVATION

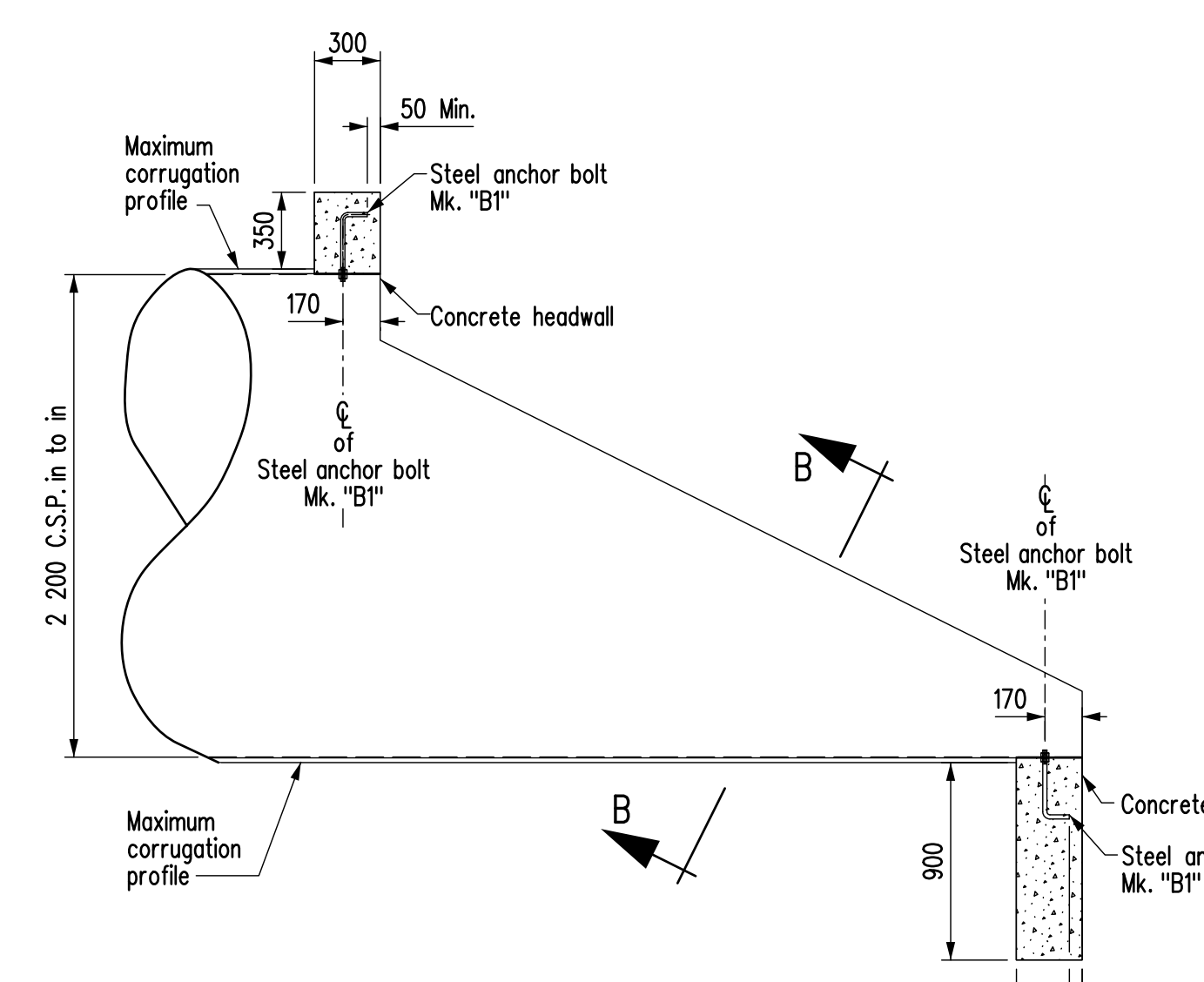

SECTION A-A

BILL OF MISCELLANEOUS METAL								
MARK No.	No.	DESCRIPTION	CORROSION PROTECTION	SIZE	LENGTH	REMARKS	MASS PER UNIT	MASS
B1	272	Steel anchor bolt Grade A36 or 307	Hot dip galvanized	19 dia.	406	As detailed, c/w 2 hex. nuts Grade C & 2 flat washers	1.138	309.54
TOTAL MASS kg =								309.54

NOTES:

1. All material noted in the above Bill shall be hot dip galvanized after fabrication in accordance with CSA G164 for a minimum net retention of 610 g/m² unless otherwise stated in the specified material ASTM standards. The fabricator and galvanizer shall safeguard against embrittlement using recommended practices from applicable standards.
2. Grade C galvanized nuts for A36/307 bolts shall be overlapped to the minimum amount required for the fastener assembly in accordance with ASTM A563.
3. All bolts and threaded rods in the above Bill shall be Imperial thread.

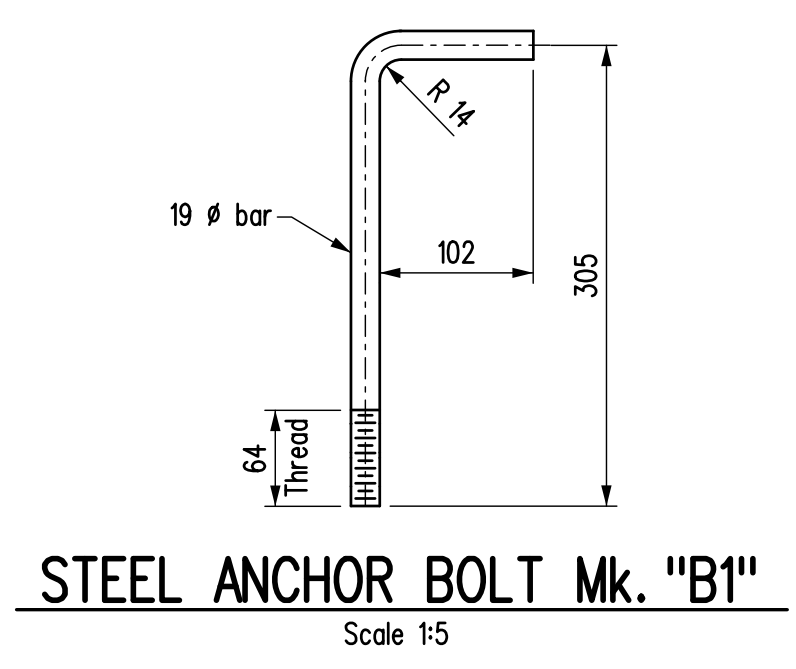

STEEL ANCHOR BOLT Mk. "B1"

Scale 1:5

REVISIONS		HEADWALL DETAILS (CONCRETE) FOR 4 - 2 200 ϕ C.S.P.'S	
DATE	BY	DESCRIPTION	APPROVED BY:
20/01/16	A.H.P.	Added washers & deleted damp proofing	Original signed by Ruth Eden
			EXECUTIVE DIRECTOR OF STRUCTURES
			DATE: June 5, 2014
			SCALE: 1:30
			SHEET No. 1 of 2
			or qs shown STD No. SC_ET_RCH_NS_4-2200

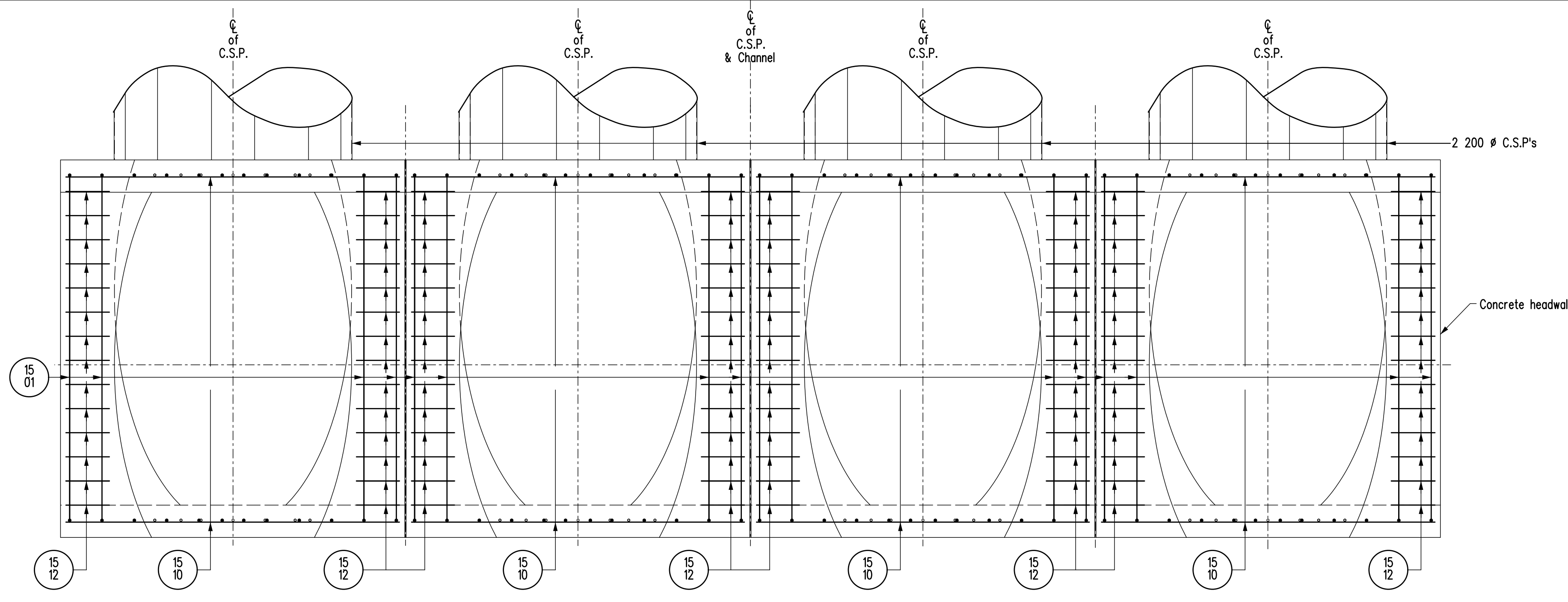

PART PLAN

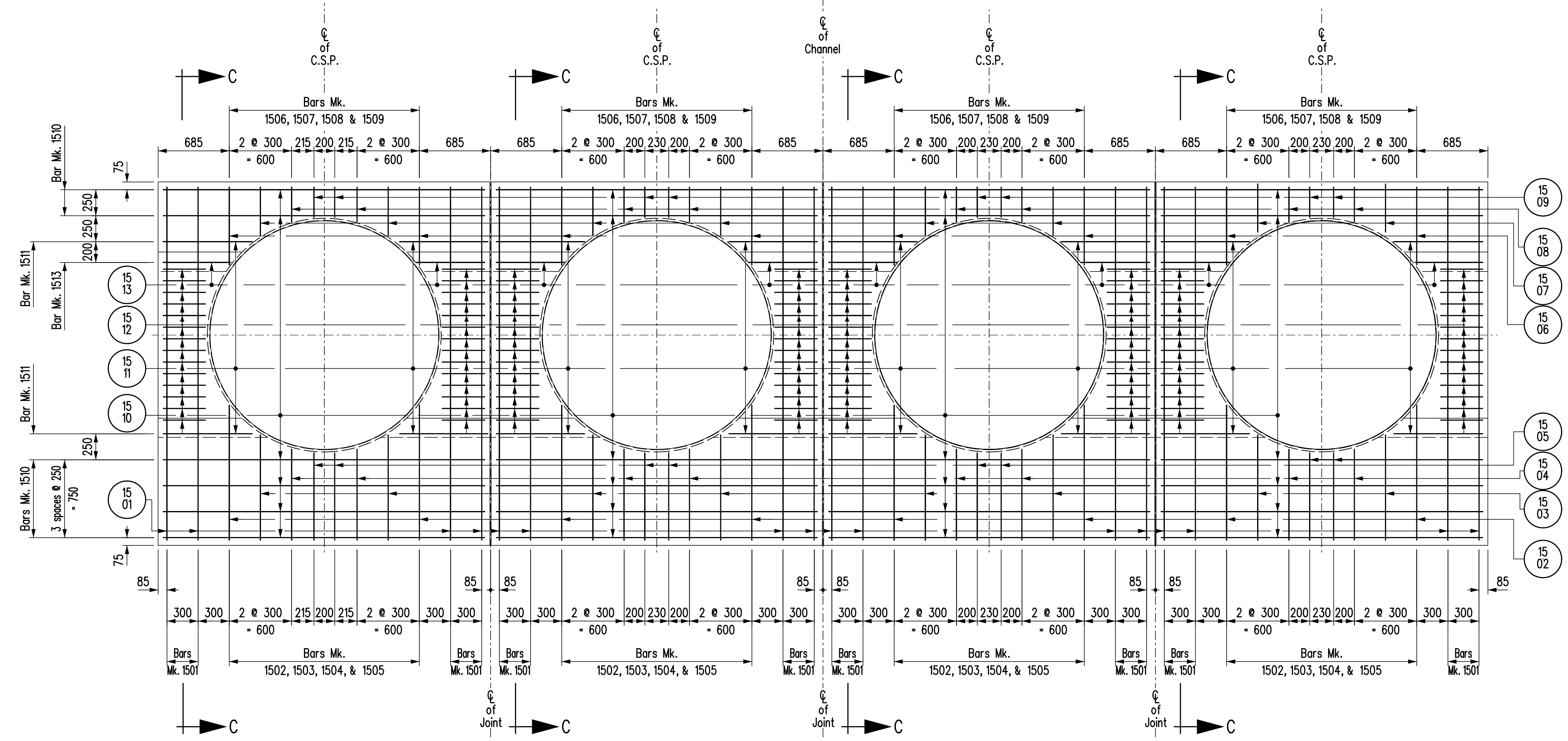

ELEVATION

BILL OF REINFORCING STEEL						FOR 2 REINFORCED CONCRETE HEADWALLS	
MARK	TYPE	PN DIAMETER	LENGTH	No.	MASS	BENDING DIAGRAM	
1501	BENT	90	5 400	32	271.30		
1502	STR		1 300	16	32.66		
1503	STR		1 010	16	25.37		
1504	STR		880	16	22.11		
1505	STR		840	16	21.10		
1506	STR		750	16	18.84		
1507	STR		460	16	11.56		
1508	STR		330	16	8.29		
1509	STR		290	16	7.28		
1510	STR		3 090	48	232.86		
1511	STR		850	32	42.70		
1512	STR		410	224	144.19		
1513	STR		650	16	16.33		

Total mass of reinforcing steel 854.59 kg
 Total volume of structural concrete 23.56 m³

NOTES:

- All dimensions given in bending diagram are out to out, except radii and extensions on 90°, 135° & 180° hooks. Extensions on 90°, 135° & 180° hooks are the "A" or "C" dimensions for the standard 90°, 135° & 180° hooks referred from the RSIC "Manual of Standard Practice". Radii are inside dimensions. All reinforcing steel bends and hooks shall conform to Clause 6.6.2 of C.S.A. A23.1-04, unless noted otherwise in the BILL OF REINFORCING STEEL.
- All reinforcing steel shall be deformed steel, unless noted otherwise in the BILL OF REINFORCING STEEL.
- All reinforcing steel shall conform to CSA G30.18-M92 "Billet Steel Bars for Concrete Reinforcement" Grade 400W, unless noted otherwise in the BILL OF REINFORCING STEEL.
- Like bars shall be bundled, securely tied and identified as to Mark and Site No. by appropriate means. All other items to be identified in a similar fashion.
- Bars marked with the suffix "P" shall be plain unformed bars in accordance with CAN/CSA G40.21-M92 Grade 300W.
- All bars shall be bent in accordance with the following detail:

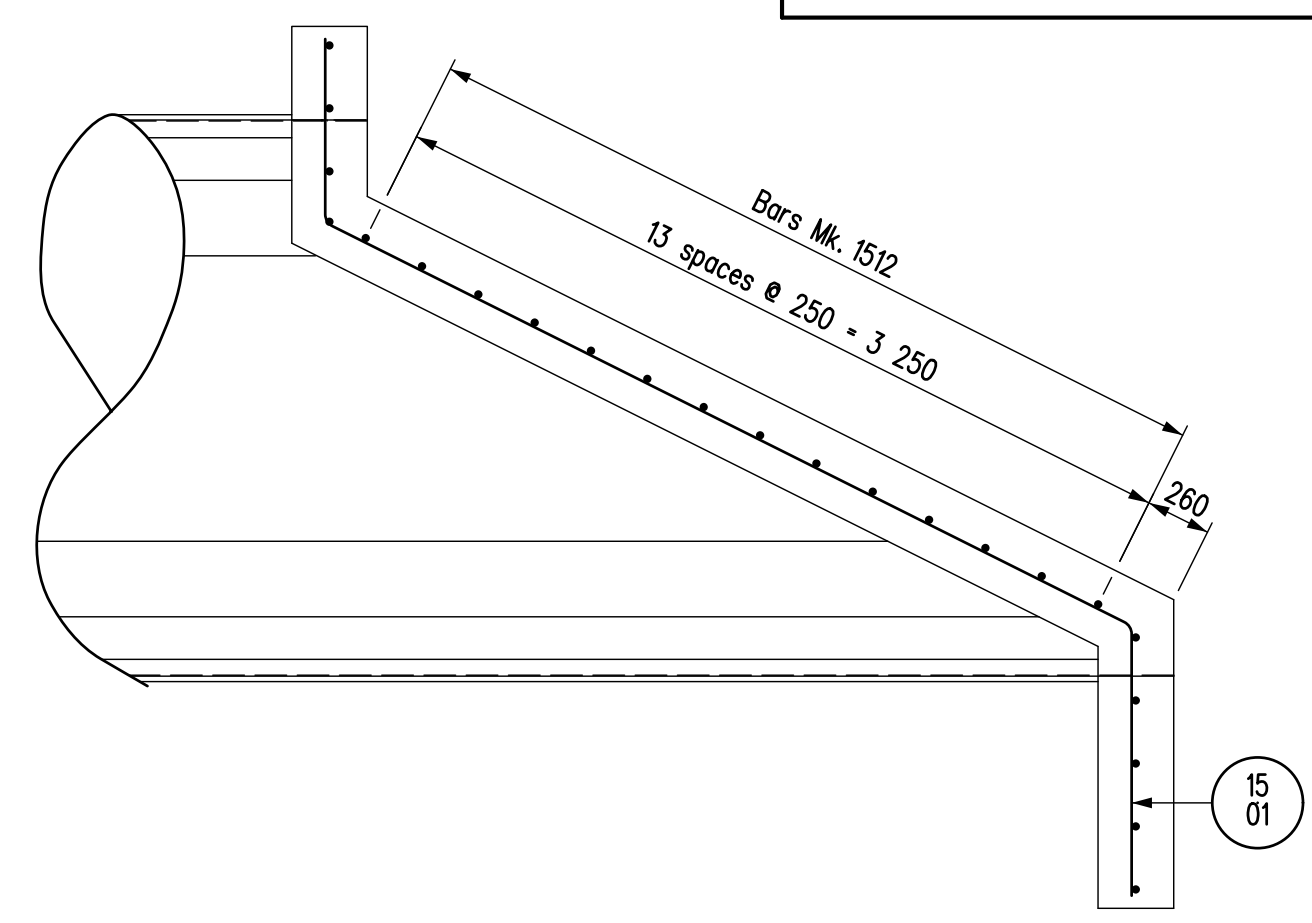

SECTION C-C

REVISIONS		HEADWALL DETAILS (REINFORCING)		FOR 4 - 2 200 Ø C.S.P.'S	
DATE	BY	DESIGN	RECORD	APPROVED BY:	
		DESIGN SEAL	RECORD SEAL	Original signed by Ruth Eden	EXECUTIVE DIRECTOR OF STRUCTURES
				DATE	June 5, 2014
				SCALE:	1:30
				SHEET No.	2 of 2
				or as shown	STD No. SC_ET_RCH_NS_4-2200

