

ELEVATION  
STEEL CHANNEL Mk. "P3"

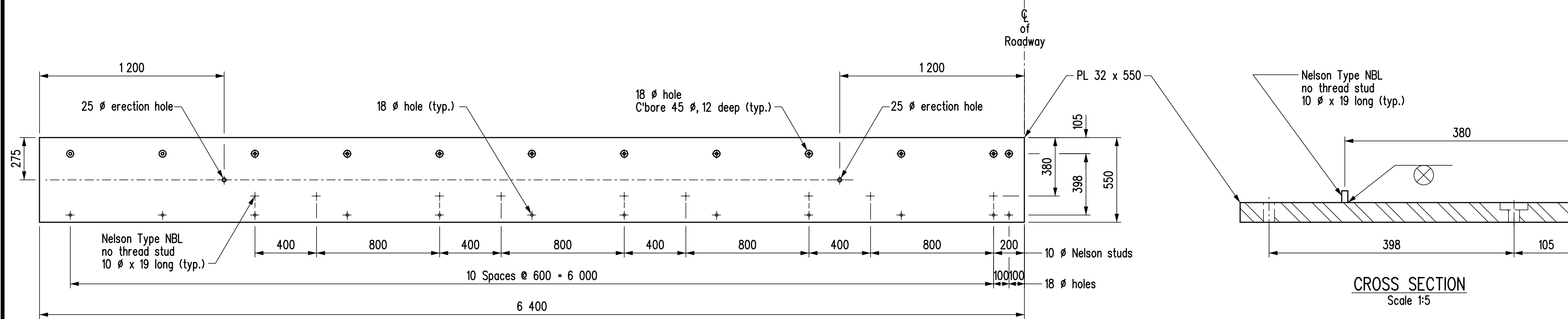
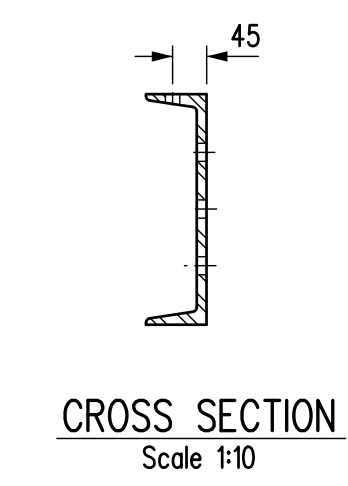

ELEVATION  
STEEL PLATE Mk. "P1" & "P1a"

CROSS SECTION  
Scale 1:5

FOR ABUTMENTS

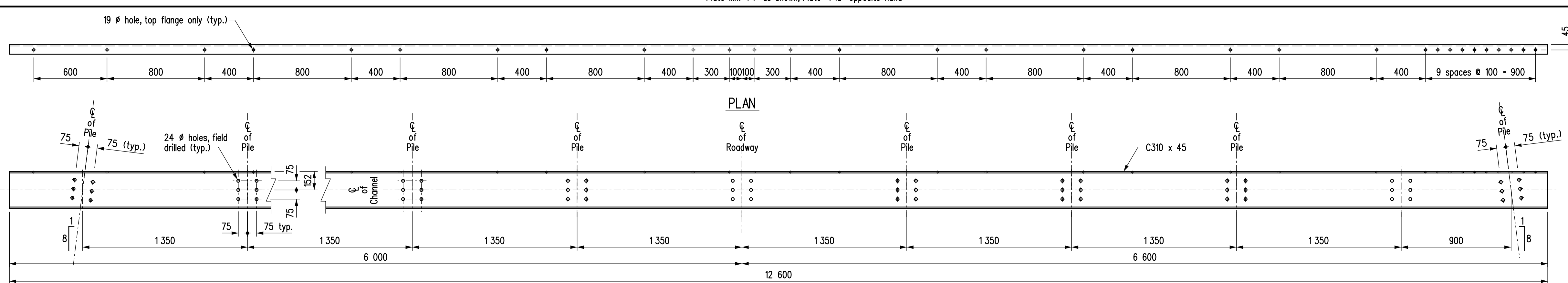

ELEVATION  
STEEL CHANNEL Mk. "P4" & "P4a"

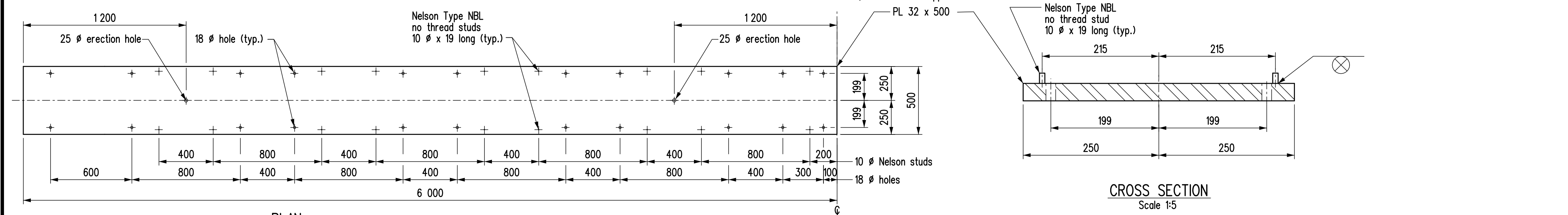
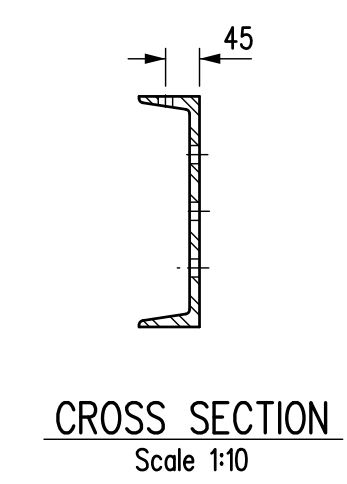

ELEVATION  
STEEL PLATE Mk. "P2"

CROSS SECTION  
Scale 1:5

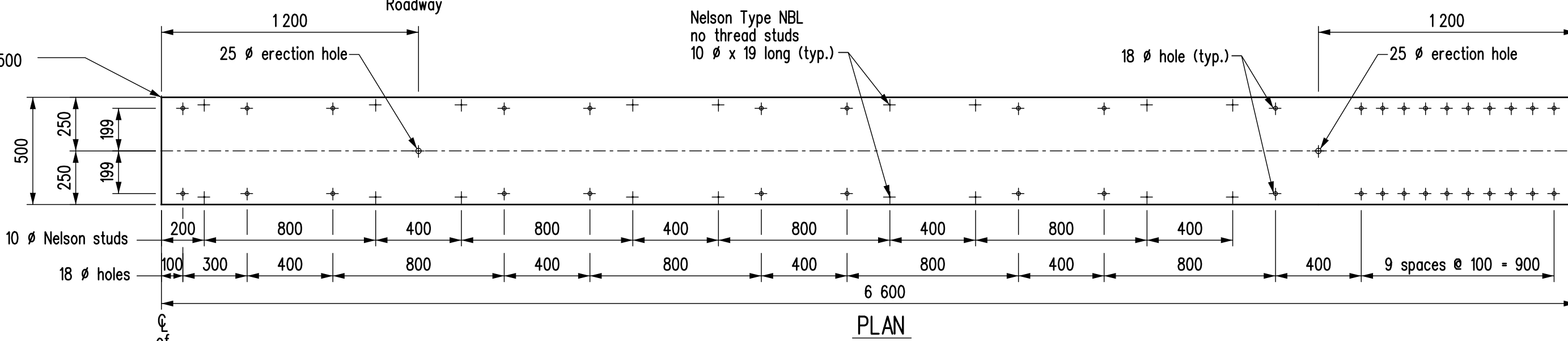

ELEVATION  
STEEL PLATE Mk. "P2a"

FOR INTERMEDIATE PILE BENTS

REVISIONS		STEEL PILE CAP DETAILS	
DATE	BY		
		<b>APPROVED BY:</b> Original signed by John Logan November 8, 2020 DIRECTOR OF STRUCTURES	
		<b>DESIGN</b> BY: A.H.P. CHECKED: A.H.P.	
		<b>DETAILS</b> BY: K.P./N.J. CHECKED: A.H.P.	
		<b>SCALE:</b> 1:20	<b>SHEET No.:</b> 1 of 2
		<b>DATE:</b> _____	<b>STANDARD:</b> STD. NO. PPCC_PR_10.8_12m_IB_SC03

Original signed and sealed by Andy Pankratz July 9, 2020

