

- NOTES:**
1. ALL DIMENSIONS ARE IN MILLIMETRES.
 2. THE ORIGINAL SEALED & SIGNED DRAWING IS IN TRAFFIC ENGINEERING.
 3. ALL SCALES ARE APPROXIMATE.

REVISIONS		
DATE	DESCRIPTION	BY
12-04	ADDED NOTES	DC

Manitoba Infrastructure and Transportation
TRAFFIC ENGINEERING



3 CABLE TO W BEAM GUARDRAIL TRANSITION

SHEET NO	1 OF 2
DATE:	2002 - 09
DRAWN:	D.C.
TSTG02	

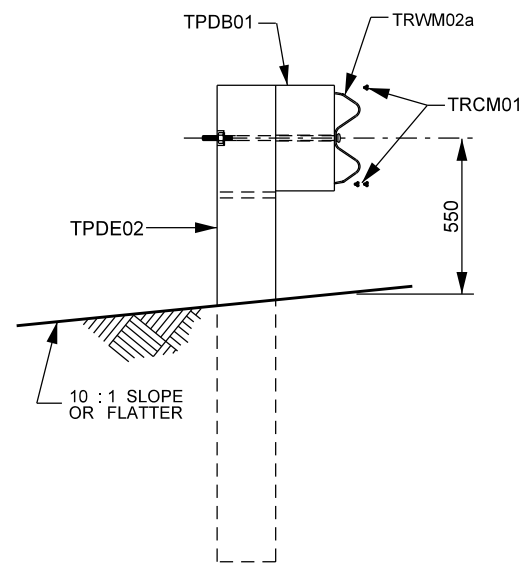

Section "B-B" 1:25

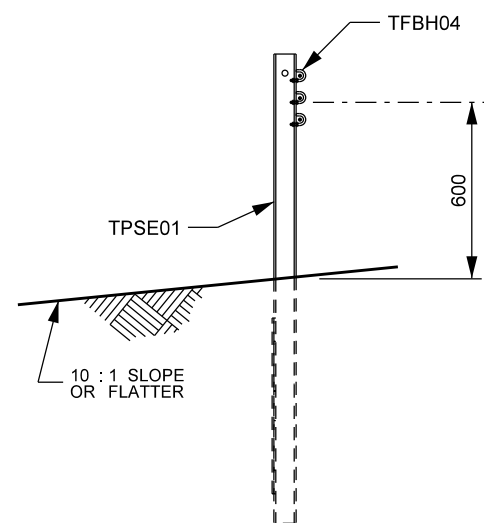

Section "C-C" 1:25

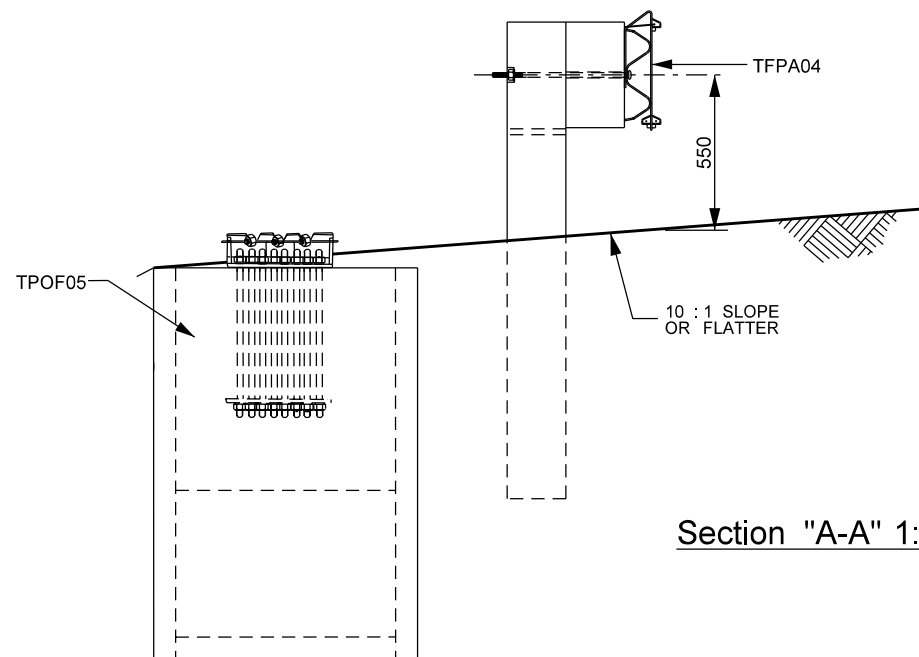

Section "A-A" 1:25

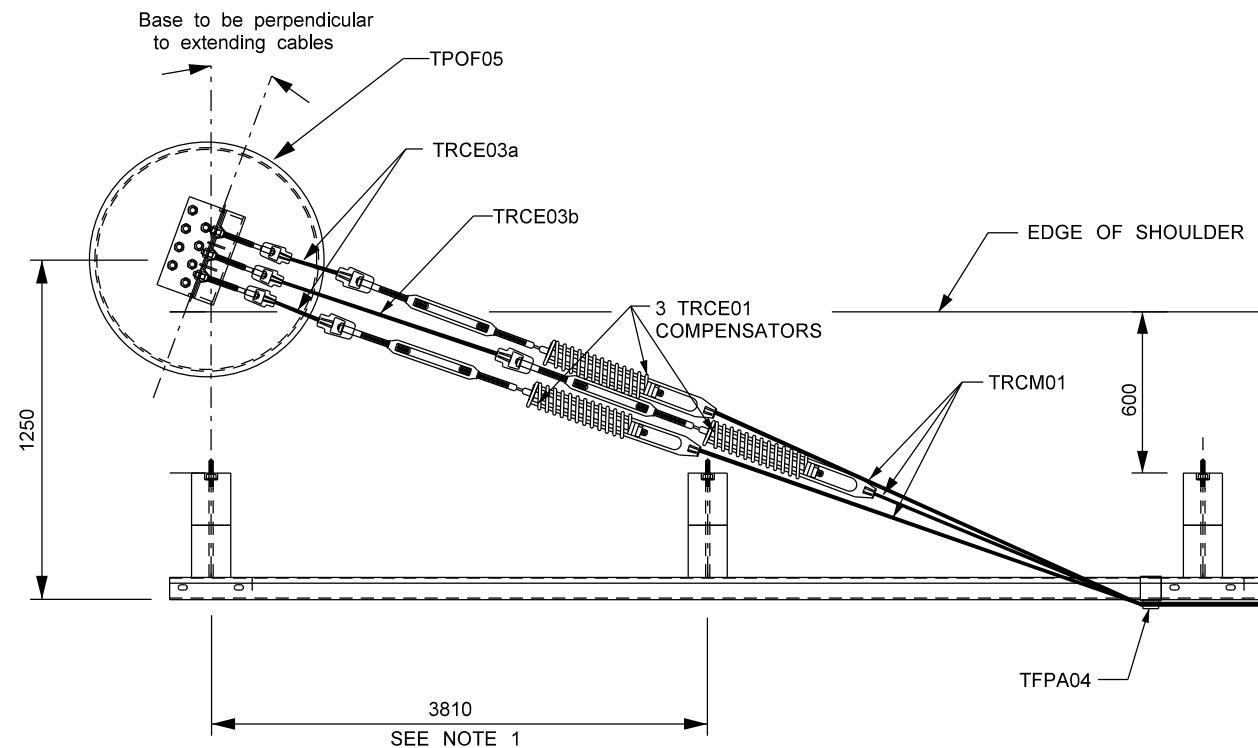

DETAIL D N.T.S.

NOTE:

1. Posts TPDE02 used in this section of rail may also be TPDE05, if used immediately adjacent to transitions TSTB05 to TSTB11.
2. All scales are approximate.

SPRING COMPRESSION CHART													
Use the following table to tension the turnbuckles in the compensating devices, based on the temperature at the time of the adjustment:													
TEMPERATURE (°C)													
50	42	37	31	26	20	15	9	4	-2	-8	-13	-19	-24
to	to	to	to	to	to	to	to	to	to	to	to	to	to
43	38	32	27	21	16	10	5	-1	-7	-12	-18	-23	-29
Total compression of 2 springs for each cable from unloaded position (mm)													
50	64	76	90	100	114	128	140	150	166	178	190	200	216
Note: The compression of the springs does not have to be equal at each end of a cable. (ie. if a total compression requires 100 mm then, 60 at one end and 40 at the other end will be satisfactory, as the total equals 100)													

NOTES:

1. ALL DIMENSIONS ARE IN MILLIMETRES.
2. THE ORIGINAL SEALED & SIGNED DRAWING IS IN TRAFFIC ENGINEERING.
3. ALL SCALES ARE APPROXIMATE.

REVISIONS		
DATE	DESCRIPTION	BY
12-04	CLARIFIED SECTION DETAILS, ADDED NOTES	DC

Manitoba Infrastructure and Transportation
TRAFFIC ENGINEERING



3 CABLE TO
W BEAM GUARDRAIL
TRANSITION

SHEET NO	2 OF 2
DATE:	2002 - 09
DRAWN:	D.C.
TSTG02	