

NOTES:

1. ALL SCALES ARE APPROXIMATE
2. LEAVE OUT ONLY REQUIRED WHERE PAVEMENT EXISTS.
3. ALL DIMENSIONS IN MILLIMETRES.
4. THE ORIGINAL SEALED AND SIGNED DRAWING IS IN TRAFFIC ENGINEERING.

REVISIONS		
DATE	DESCRIPTION	BY
2014/04	LEAVEOUT AND PLAN DETAILS ADDED	HL

Manitoba 
Infrastructure and Transportation
 TRAFFIC ENGINEERING



**STRONG - POST
 W - BEAM GUARDRAIL**

SHEET NO	1 OF 2
DATE:	2002 - 09
DRAWN:	D.C.
TSGR04b	

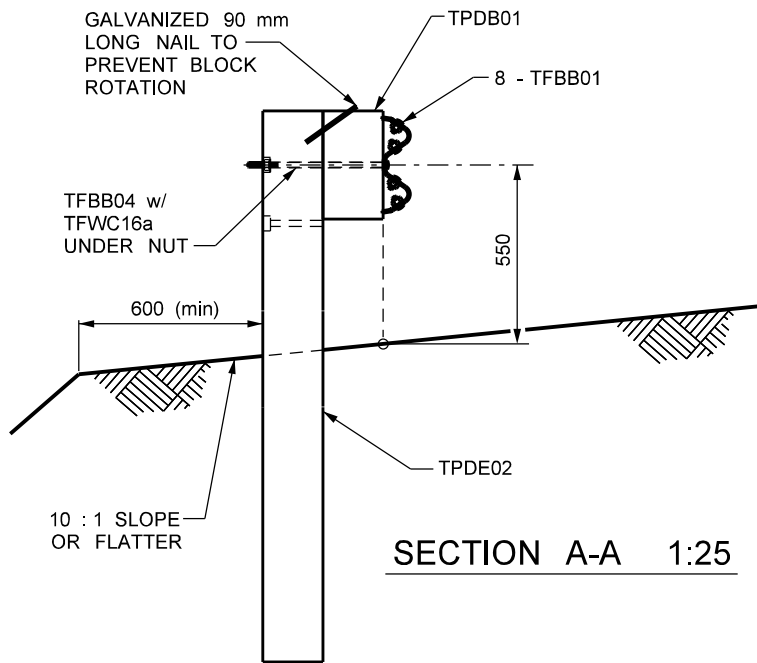

SECTION A-A 1:25

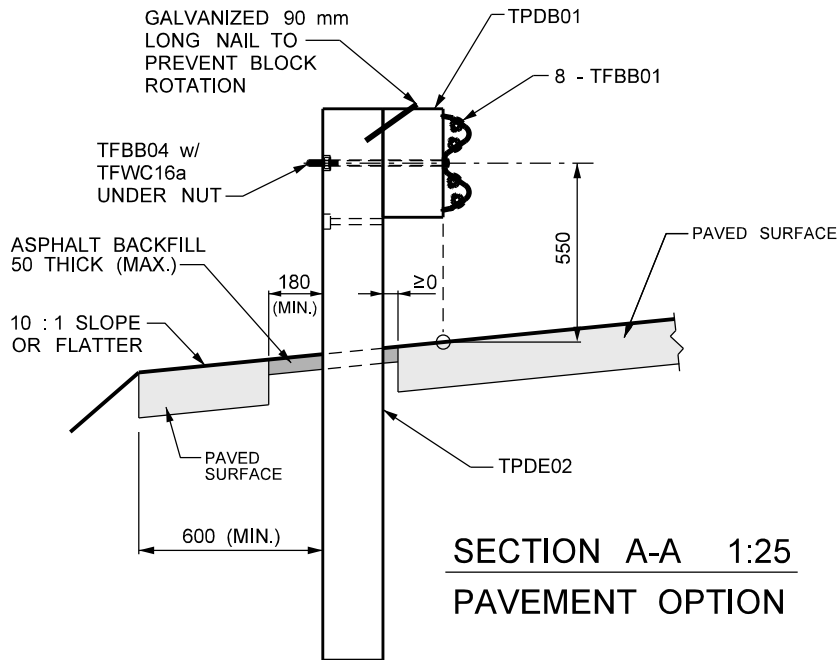

SECTION A-A 1:25
PAVEMENT OPTION

REVISIONS		
DATE	DESCRIPTION	BY
2014/04	LEAVEOUT AND PLAN DETAILS ADDED	HL

Manitoba 
Infrastructure and Transportation
 TRAFFIC ENGINEERING



STRONG - POST
 W - BEAM GUARDRAIL

SHEET NO	2 OF 2
DATE:	2002 - 09
DRAWN:	D.C.

TSGR04b