

PLAN 1:25

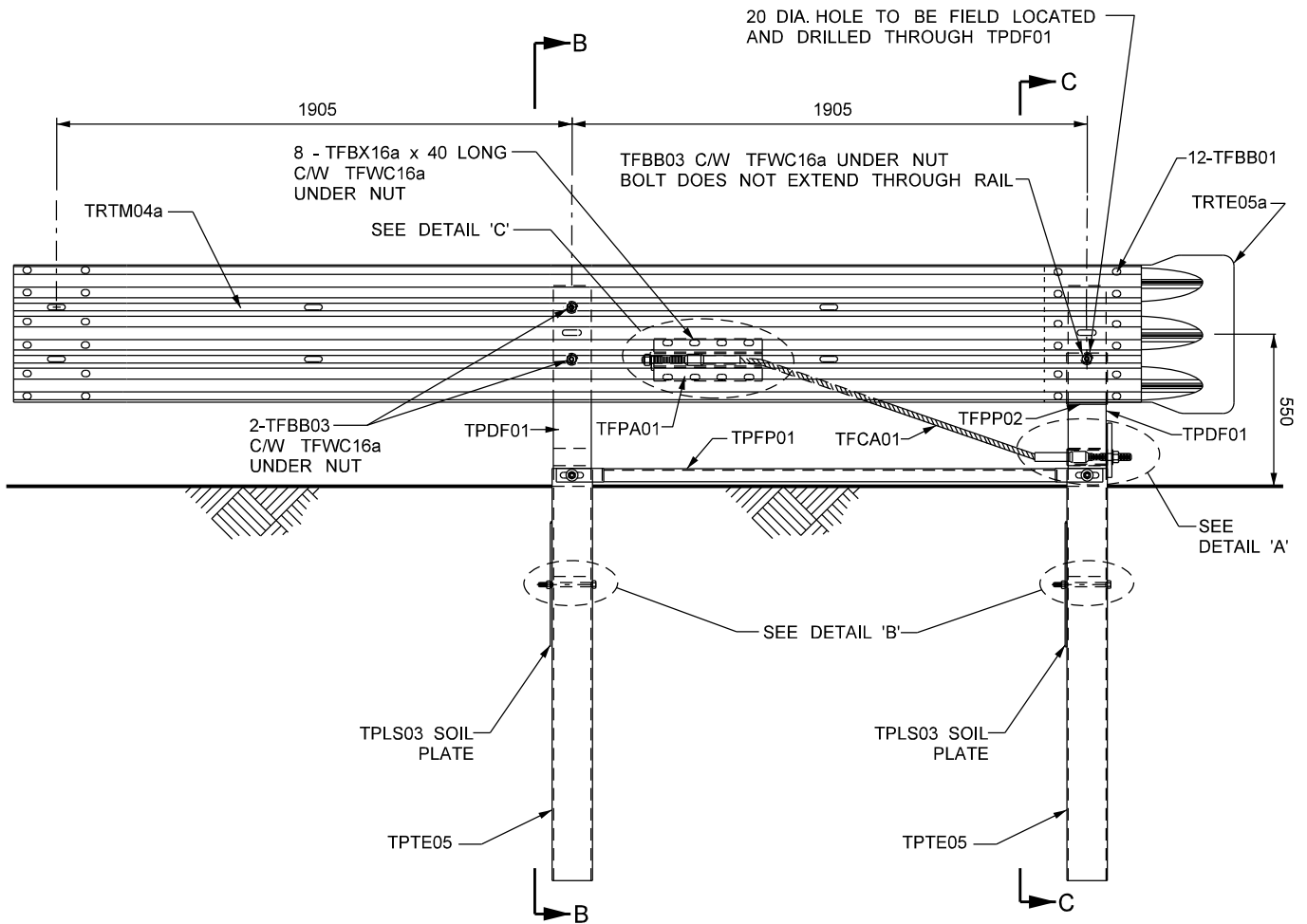

ELEVATION 1:25

NOTES:

1. ALL SCALES ARE APPROXIMATE.
2. ALL DIMENSIONS ARE IN MILLIMETRES.
3. THE ORIGINAL SEALED AND SIGNED DRAWING IS IN TRAFFIC ENGINEERING.
4. ADJUSTMENT OF THE YOKE(S) MAY BE REQUIRED IN THE FIELD TO ACCOMMODATE ASSEMBLY.

REVISIONS		
DATE	DESCRIPTION	BY
2014 /03	REVISED LAYOUT	HL

Manitoba 
Infrastructure and Transportation
 TRAFFIC ENGINEERING



THREE BEAM TRAILING
 END TERMINAL
 FOUNDATION TUBE OPTION

SHEET NO	1 OF 2
DATE:	2002 - 09
DRAWN:	D.C.

TSET02a

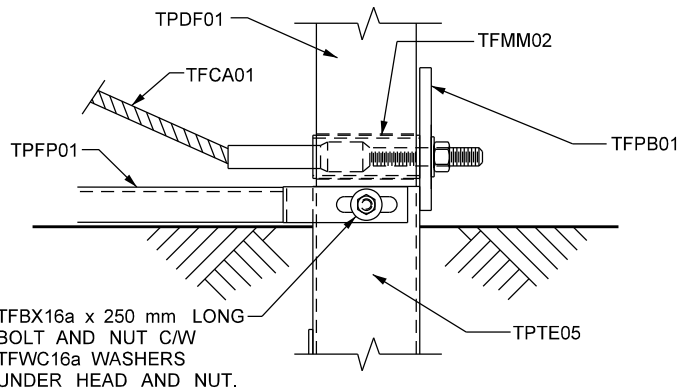

DETAIL 'A' 1:10

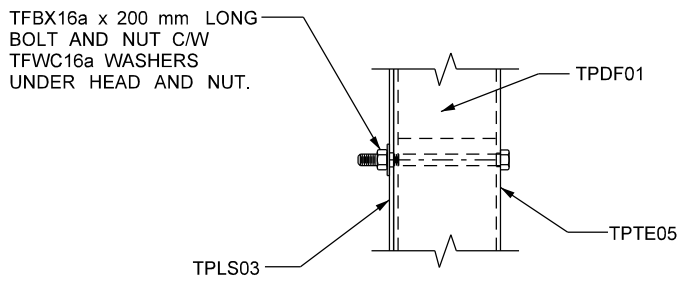

DETAIL 'B' 1:10

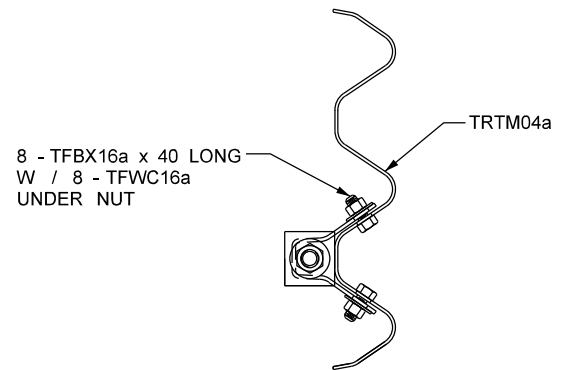

VIEW A-A

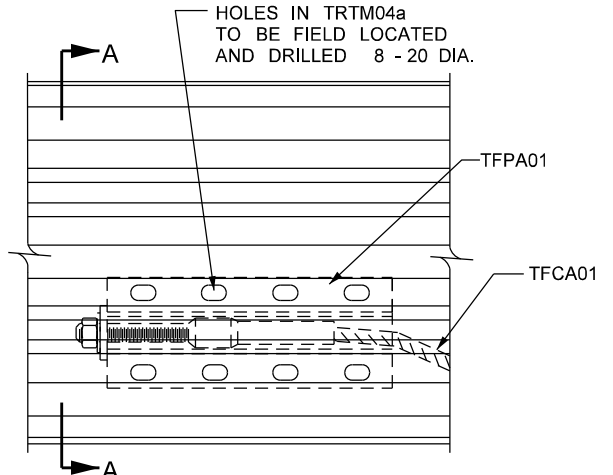

DETAIL 'C' 1:10

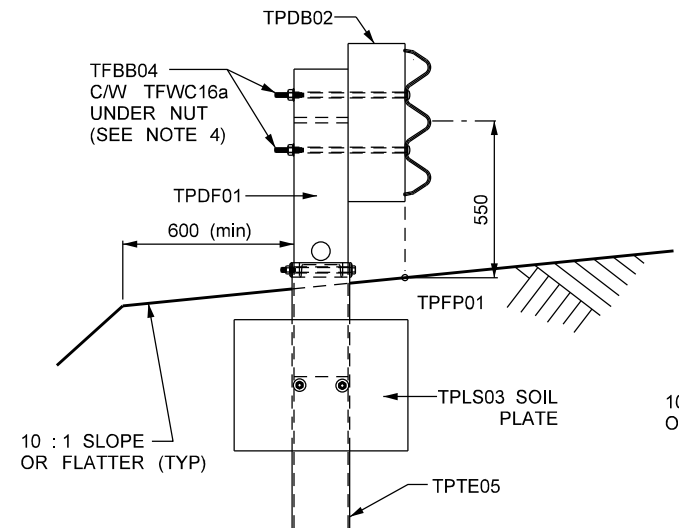

VIEW B-B 1:25

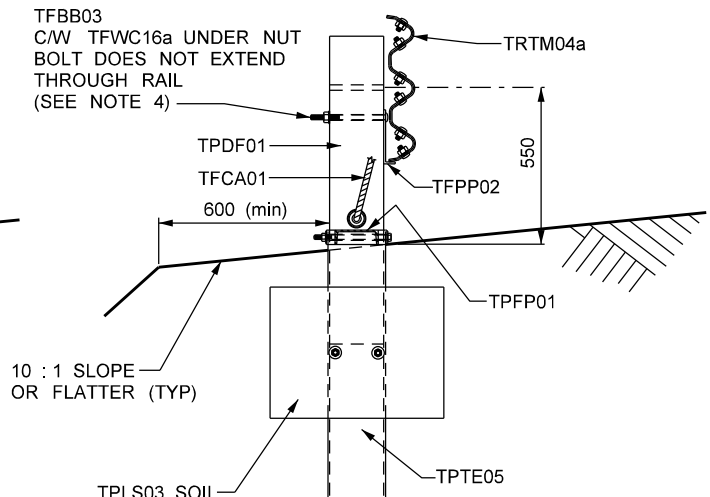

VIEW C-C 1:25

NOTES:

1. ALL SCALES ARE APPROXIMATE.
2. ALL DIMENSIONS ARE IN MILLIMETRES.
3. THE ORIGINAL SEALED AND SIGNED DRAWING IS IN TRAFFIC ENGINEERING.
4. FIELD LOCATE AND DRILL TWO 20 mm DIA. HOLES TO ACCOMODATE BOLT TFBB04 OR TFBB03.

REVISIONS		
DATE	DESCRIPTION	BY
2014 /03	REVISED LAYOUT	HL

Manitoba Infrastructure and Transportation
TRAFFIC ENGINEERING



THRE BEAM TRAILING
END TERMINAL
FOUNDATION TUBE OPTION

SHEET NO	2 OF 2
DATE:	2002 - 09
DRAWN:	D.C.

TSET02a