

# QuadGuard® II

## Assembly Manual



**TRINITY**  
**HIGHWAY**

*Ahead of the Curve™*

# QuadGuard<sup>®</sup> II

The QuadGuard<sup>®</sup> II system has been tested pursuant to National Cooperative Highway Research Program (“NCHRP”) Report 350 specifications. The QuadGuard<sup>®</sup> II system has been deemed eligible for federal-aid reimbursement on the National Highway System (“NHS”) by the Federal Highway Administration (“FHWA”) as a TL-2 or TL-3 device.

## Assembly Manual



2525 N. Stemmons Freeway  
Dallas, Texas 75207



**Important:** These instructions are to be used only in conjunction with the assembly, maintenance, and repair of QuadGuard<sup>®</sup> II systems. These instructions are for standard assembly specified by the appropriate highway authority only. In the event the specified system assembly, maintenance, or repair would result in a deviation from these assembly instructions, contact the appropriate highway authority engineer. This system has been deemed eligible by the FHWA for use on the NHS under criteria utilized by that agency. **Trinity Highway** representatives are available for consultation if required.

**This manual must be available to the worker overseeing and/or assembling the product at all times. For additional copies, contact Trinity Highway directly (888) 323-6374 or visit [www.trinityhighway.com](http://www.trinityhighway.com).**

The instructions contained in this manual supersede all previous information and manuals. All information, illustrations, and specifications in this manual are based on the latest QuadGuard<sup>®</sup> II system information available to Trinity Highway at the time of printing. We reserve the right to make changes at any time. Please contact Trinity Highway to confirm that you are referring to the most current instructions.

## **Table of Contents**

Customer Service Contacts .....	3
Important Introductory Notes .....	3
Safety Rules for Assembly .....	4
Safety Symbols .....	5
Warnings and Dangers .....	5
Limitations and Warnings.....	6
System Overview .....	7
System Components for Replacement .....	8
QuadGuard® II Foundation/Anchoring .....	13
Trinity Highway Approved Adhesive Anchoring System .....	15
Assembly Cautions .....	16
Horizontal Assemblies.....	17
Recommended Tools.....	18
Narrow Systems.....	23
Site Preparation/Foundation Narrow.....	24
Assembly Narrow.....	25
Transition Panel Types Narrow.....	26
Wide Systems .....	42
Site Preparation/Foundation Wide .....	43
Assembly Wide .....	44
Transition Panel Types Wide .....	45
Maintenance and Repair.....	60
Inspection Frequency.....	60
Visual Drive-By Inspection .....	60
Walk-Up Inspection .....	60
Post-Impact Instructions .....	61
Parts Ordering Procedure .....	64

## Customer Service Contacts

Trinity Highway is committed to the highest level of customer service. Feedback regarding the QuadGuard® II system, its assembly procedures, supporting documentation, and performance is always welcome. Additional information can be obtained from the contact information below:

### Trinity Highway

Telephone:	(888) 323-6374 (USA) +1 312 467 6750 (International)
E-mail:	product.info@trin.net
Website:	www.trinityhighway.com

## Important Introductory Notes

Proper assembly of the QuadGuard® II system is critical to achieve performance that has been evaluated and deemed eligible by the FHWA per NCHRP Report 350. These instructions should be read in their entirety and understood before assembling the QuadGuard® II system. These instructions are to be used in conjunction with the assembly of QuadGuard® II system and are for standard assemblies only as specified by the applicable highway authority. If you need additional information, or have questions about the QuadGuard® II system, please contact the highway authority that has planned and specified this assembly and, if needed, contact Trinity Highway's Customer Service Department. This product must be assembled in the location specified by the appropriate highway authority. If there are deviations, alterations, or departures from the assembly instructions specified in this manual, the device may not perform as tested.



**Important: DO NOT** use any component part that has not been specifically approved for this system during the assembly or repair of this system (see p. 8 – 12 for component parts).



This product has been specified for use by the appropriate highway authority and has been provided to that user who has unique knowledge of how this system is to be assembled. No person should be permitted to assemble, maintain, or repair this system that does not possess the unique knowledge described above. These instructions are intended for an individual qualified to both read and accurately interpret them as written. These instructions are intended only for an individual experienced and skilled in the assembly of highway products that are specified and selected by the highway authority.

A manufacturer's drawing package will be supplied by Trinity Highway upon request. Each system will be supplied with a specific drawing package unique to that system. Such drawings take precedence over information in this manual and shall be studied thoroughly by a qualified individual who is skilled in interpreting them before the start of any product assembly.



**Important:** Read safety instructions thoroughly and follow the assembly directions and suggested safe practices before assembling, maintaining, or repairing the QuadGuard® II system. Failure to follow this warning can result in serious injury or death to workers and/or bystanders. Please keep up-to-date instructions for later use and reference by anyone involved in the assembly of the product.



**Warning:** Ensure that all of the QuadGuard® II system Danger, Warning, Caution, and Important statements within the QuadGuard® II manual are completely followed. Failure to follow this warning could result in serious injury or death in the event of a collision.

## **Safety Rules for Assembly**

### **\* Important Safety Instructions \***

This manual must be kept in a location where it is readily available to persons who are skilled and experienced in the assembly, maintenance, or repair of the QuadGuard® II system. Additional copies of this manual are available from Trinity Highway by calling (888) 323-6374, or by email at [product.info@trin.net](mailto:product.info@trin.net), or at [www.trinityhighway.com](http://www.trinityhighway.com). Please contact Trinity Highway if you have any questions concerning the information in this manual or about the QuadGuard® II system.

Always use appropriate safety precautions when operating power equipment, mixing chemicals, and when moving heavy equipment or QuadGuard® II components. Safety articles including but not necessarily limited to work gloves, apron, safety goggles, safety-toe shoes, and back protection should be used.



**Warning:** Safety measures incorporating appropriate traffic control devices specified by the highway authority must be used to protect all personnel while at the assembly, maintenance, or repair site.

## Safety Symbols

This section describes the safety symbols that appear in this QuadGuard® II manual. Read the manual for complete safety, assembly, operating, maintenance, repair, and service information.

### Symbol

### Meaning



**Safety Alert Symbol:** Indicates Important, Caution, Warning, or Danger. Failure to read and follow the Important, Caution, Warning, or Danger indicators could result in serious injury or death to the workers and/or bystanders.

## Warnings and Dangers

Read all instructions before assembling, maintaining, or repairing the QuadGuard® II system.



**Danger:** Failure to comply with these warnings could result in increased risk of serious injury or death in the event of a vehicle impact with a system.



**Warning:** Do not assemble, maintain, or repair the QuadGuard® II system until you have read this manual thoroughly and completely understand it. Ensure that all Danger, Warning, Caution, and Important statements within the manual are completely followed. Please call Trinity Highway at (888) 323-6374 if you do not understand these instructions.



**Warning:** Do NOT modify the QuadGuard® II system in any way.



**Warning:** Ensure that the QuadGuard® II system and delineation used meet all federal, state, specifying agency, and local specifications.



**Warning:** Ensure delineation on the assembly meets all appropriate Manual on Uniform Traffic Control Devices ("MUTCD") and local standards.



**Important:** It is the sole responsibility of the project engineer and/or the local highway authority and its engineers to determine whether use or reuse of any part of the system is appropriate or acceptable following an impact. Trinity Highway makes no recommendation or suggestion regarding this determination. Each impact is unique.



**Important:** It is critical that you inspect this product after assembly is complete to make certain that the instructions provided in this manual have been strictly followed.

## **Limitations and Warnings**

Trinity Highway contracts with FHWA approved testing facilities to perform crash tests, evaluate test results, and submit results to the Federal Highway Administration for review.

The QuadGuard® II system has been deemed eligible for reimbursement by FHWA as meeting the requirements and guidelines of NCHRP Report 350. NCHRP Report 350 tests are designed to evaluate product performance involving a range of vehicles on roadways, from lightweight cars (approx. 820 kg [1800 lb.]) to full size pickup trucks (approx. 2000 kg [4400 lb.]). A product can be certified for multiple Test Levels. The QuadGuard® II system is certified to the Test Level(s) as shown below:

**Test Level 2: 70 km/h [43 mph]**

**Test Level 3: 100 km/h [62 mph]**

**These FHWA directed tests are not intended to represent the performance of systems when impacted by every vehicle type or every impact condition existing on the roadway. This system is tested only to the test matrix criteria of NCHRP Report 350 as approved by FHWA.**

Trinity Highway expressly disclaims any warranty or liability for injury or damage to persons or property resulting from any impact, collision or harmful contact with products, other vehicles, or nearby hazards or objects by any vehicle, object or person, whether or not the products were assembled in consultation with Trinity Highway or by third parties.

The QuadGuard® II system is intended to be assembled, delineated, and maintained within specific state and federal guidelines. It is important for the highway authority specifying the use of a highway product to select the most appropriate product configuration for its site specifications. The customer should be careful to properly select, assemble, and maintain the product. Site lay out, vehicle population type; speed, traffic direction, and visibility are important elements that require evaluation in the selection of a highway product. For example, curbs could cause an untested effect on an impacting vehicle.

After an impact occurs, the debris from the impact should be removed from the area immediately and the specified highway product should be evaluated and restored to its original specified condition or replaced as the highway authority determines as soon as possible.

## **System Overview**

The QuadGuard® II system is a potentially reusable, re-directive, non-gating crash cushion for roadside obstacles ranging in width from 610 mm to 3200 mm (24" to 126"). It consists of energy-absorbing cartridges surrounded by a framework of Quad-Beam™ Panels. The decision as to whether this product is reusable after impact rests solely within the sound discretion of the trained engineer, experienced in highway products, who is working at the direction of the local DOT, or appropriate highway authority, which specified and now owns the product.

The QuadGuard® II system utilizes two types of cartridges in a staged configuration designed to address both lighter cars and heavier, high center-of-gravity vehicles. Its modular design allows the system length to be tailored to the design speed of a site. See the QuadGuard® II Product Manual to determine the appropriate number of Bays (see p. 66 & 67 for an illustration of Bay) for a given speed.

### **Impact Performance**

The 5 Bay QuadGuard® II systems have successfully passed the requirements outlined in NCHRP Report 350, Test Level 3 tests with both the light car and pickup at speeds of up to 100 km/h [62 mph] at angles up to 20 degrees.

During head-on impact testing, within NCHRP Report 350 criteria, the QuadGuard® II system is designed to telescope rearward to absorb the energy of impact. When impacted from the side, within the applicable NCHRP Report 350 criteria, it is designed to redirect the vehicle back toward its original travel path and away from the roadside obstacle.

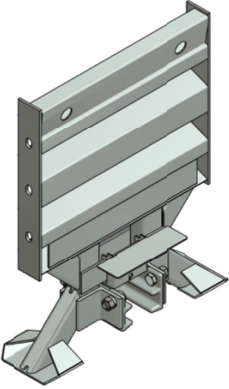
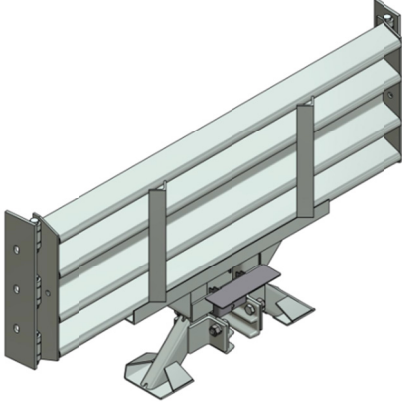
## System Components for Replacement

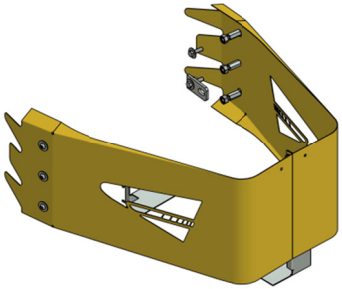
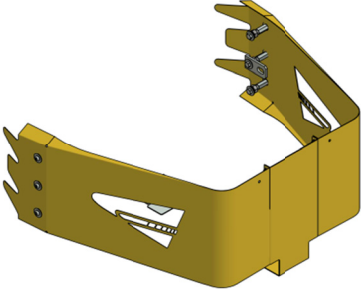
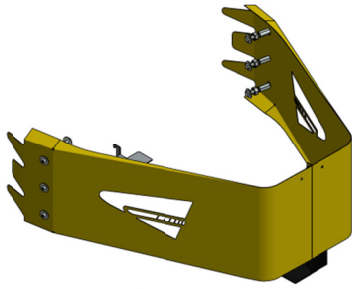
Below is a list of system components to be used in the repair of your particular QuadGuard® II configuration. Please call Trinity Highway customer support if you have any system questions (see p. 3).



**Warning:** Use only Trinity Highway parts that are specified herein for the QuadGuard® II for assembling, maintaining, or repairing the QuadGuard® II system. **Do not utilize or otherwise comingle parts from other systems even if those systems are other Trinity Highway systems.** Such configurations have not been tested, nor have they been deemed eligible for use. Assembly, maintenance, or repairs using unspecified parts or accessories is strictly prohibited.

**Note:** Components are not shown to scale.

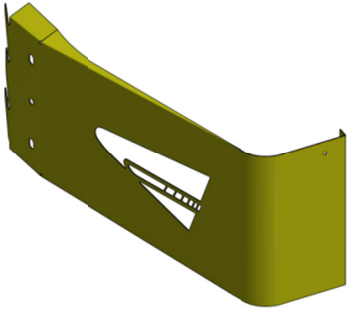
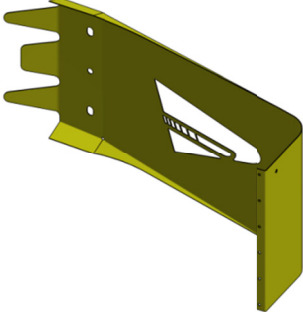
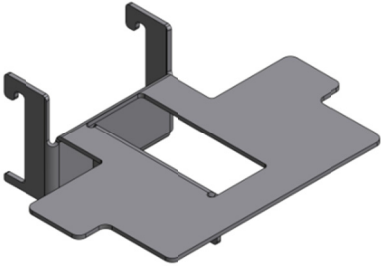
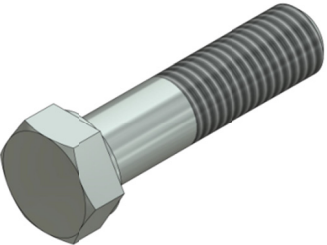
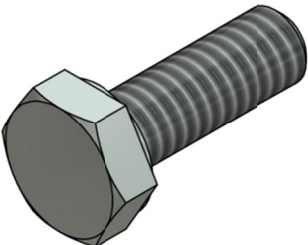
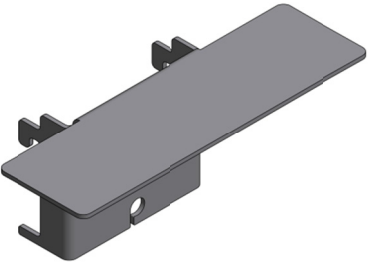
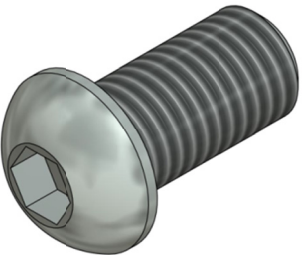
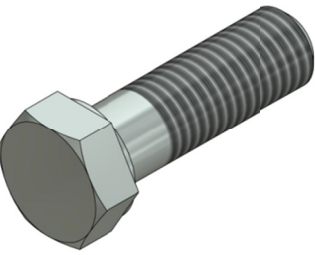
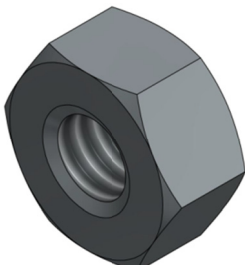
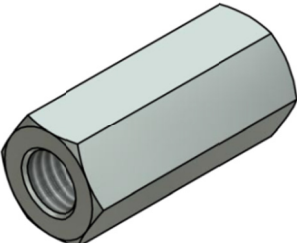


Narrow Diaphragm Assemblies *	Wide Diaphragm Assemblies *		
 <p>607113 - 24" 607114 - 30" 607115 - 36" 606810 - 48"</p>	<p>607173 - 26.48" 607175 - 32.78" 607176 - 35.93" 607177 - 39.08" 607145 - 42.23" 607146 - 45.38"</p>	<p>607148 - 48.53" 607149 - 50.11" 607150 - 51.68" 607151 - 54.83" 607152 - 57.98" 607156 - 59.56"</p>	 <p>607157 - 61.13" 607158 - 64.28" 607159 - 68.06" 607160 - 70.58" 607162 - 73.73" 607163 - 76.88"</p>

Nose, Narrow Assembly *	Nose, Narrow Assembly 48" *	Nose, Wide Assembly *
 <p>611580 - Galvanized 611581 - Yellow 611579 - Black</p>	 <p>611577 - Galvanized 611578 - Yellow 611576 - Black</p>	 <p>611583 - Galvanized 611584 - Yellow 611582 - Black</p>

\*Parts in red are included in assemblies.


<p>Mushroom Washer</p> 	<p>Flat Screw 5/8X8 1/2" Wide</p> 	<p>Spring, 6", Wide</p> 
<p>617045</p>	<p>116879</p>	<p>117458</p>
<p>Flat Screw 5/8X5", G8, Narrow</p> 	<p>Spring, 1 1/2", Narrow</p> 	<p>Rail Nut, Hex, 5/8"</p> 
<p>116878</p>	<p>117458</p>	<p>003340</p>
<p>Rail Bolt, 5/8X2"</p> 	<p>Panel, Fender Assembly, QG</p> 	<p>Washer, Flat, 5/8" X 1 3/4"</p> 
<p>003400</p>	<p>608236</p>	<p>003300</p>
<p>Nose, L, Wide, W/Logo</p> 	<p>Nose, R, Wide, W/Logo</p> 	<p>Bracket, Cart Support, Nose</p> 
<p>611672</p>	<p>611683</p>	<p>605430</p>

**\*Parts in red are included in assemblies.**

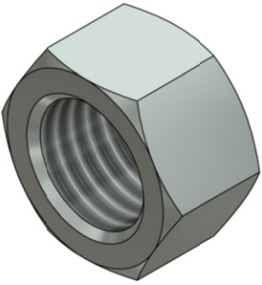

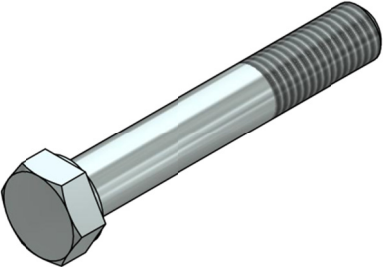
<p>Nose, L, Narrow, W/Logo</p> 	<p>Nose, R, Narrow, W/Logo</p> 	<p>Bracket, Cart, Nose</p> 
<p>611669</p>	<p>611680</p>	<p>605420</p>
<p>Bolt, Hex 5/8" X 2 1/2", G5</p> 	<p>Bolt, Hex, 1/4" X 3/4", G5</p> 	<p>Bracket, Cartridge Support</p> 
<p>118232</p>	<p>113518</p>	<p>605446</p>
<p>Bolt, Bt, 5/8" X 1 1/4", Hex Socket</p> 	<p>Bolt, Hex, 5/8" X 2", G5</p> 	<p>Nut, Hex, 1/4"</p> 
<p>113404</p>	<p>118570</p>	<p>115946</p>
<p>Nut, Hex, Coupling, 5/8" 11" X 2 1/8"</p> 	<p>Washer, Lock, 1/4"</p> 	<p>Washer, Lock, 5/8"</p> 
<p>115986</p>	<p>118085</p>	<p>118100</p>

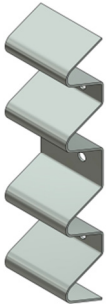
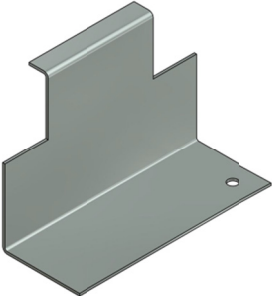
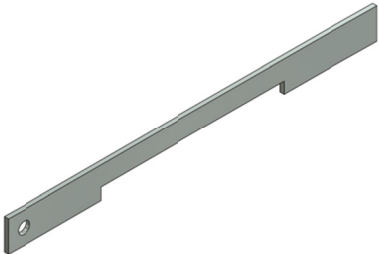
**\*Parts in red are included in assemblies.**

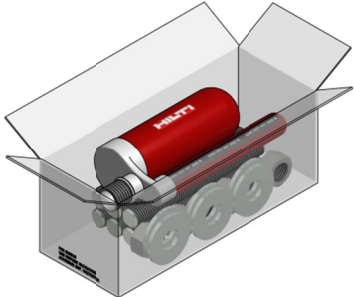
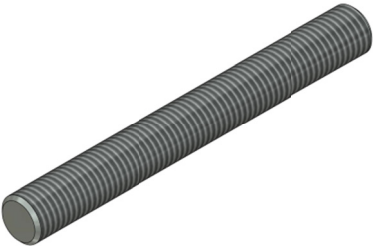
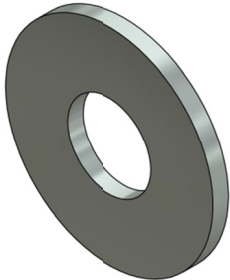


<p>Bracket, Angle, 2" X 1", W/Holes</p>  <p>617387</p>	<p>Washer, Flat 3/8" X 1"</p>  <p>118036</p>	<p>Nut, Hex, 3/8" X 1"</p>  <p>115960</p>
<p>Bolt, Hex, 3/8" X 1", G5</p>  <p>113596</p>	<p>Washer, Flat, 3/8" X 2"</p>  <p>118038</p>	<p>Bolt, Hex, 5/8" X 1 1/2", G5</p>  <p>113654</p>
<p>Bracket, Pull-Out</p>  <p>605535</p>	<p>Shim Kit, 1/8" X 3 5/8" X 8"(2)</p>  <p>614050</p>	<p>Washer, Lock, 3/4"</p>  <p>118089</p>
<p>Bolt, Hex, 3/4" X 2", G8</p>  <p>113555</p>	<p>Monorail Guide</p>  <p>611368</p>	<p>Nut, Heavy Hex, 3/4"</p>  <p>003704</p>



**\*Parts in red are included in assemblies.**

<p>Nut, Heavy Hex, 5/8"</p>  <p>003354</p>	<p>Hinge Plate, Fender Panel</p>  <p>610172</p>	<p>Bolt, Hex, 5/8" X 4", G5</p>  <p>113666</p>
---	--	---

<p>Panel, Side, QG</p>  <p>611898</p>	<p>Bracket, Cartridge Support TS B/U</p>  <p>605447</p>	<p>Locking Bar, Cartridge Support</p>  <p>611266</p>
--	--	---

<p>Approved Adhesive *</p>  <p>619316</p>	<p>Stud, 7", G5</p>  <p>117542</p>	<p>Washer, Flat, 3/4"</p>  <p>118027</p>
--	---	---

\*See Trinity Highway Approved Adhesive Anchoring System section on page 15.

<p>Cartridge Assy, Type I</p>  <p>606027</p>	<p>Cartridge Assy, Type II</p>  <p>606029</p>
---	---

## QuadGuard® II Foundation/Anchoring



**Warning:** Ensure the proposed assembly site conforms with the guidance provided by the AASHTO Roadside Design Guide, including, but not limited to, guidance regarding placement on or adjacent to curbs.

### **Asphalt Installations**

Systems with a Tension-Strut Backup may be temporarily installed in construction zones on asphalt. Assemblies on asphalt must provide a minimum of 76 mm [3"] layer of asphalt over a minimum of 76 mm [3"] layer of Portland Cement concrete, 152 mm [6"] layer of asphalt over 152 mm [6"] layer of subbase, or 203 mm [8"] layer of asphalt with no subbase.



**Important:** Only 460 mm [18"] threaded rods, utilizing Trinity Highway approved adhesive, can be used with (asphalt) foundations. Contact Customer Service at (888) 323-6374 for a complete list of approved adhesives.

### **Concrete Installations**

For concrete installations, the QuadGuard® II system should be installed only on an existing or freshly placed and cured concrete base (28 MPa [4000 psi] minimum). Orientation of the concrete base and the attenuator must comply with the project plans or as otherwise determined by the project engineer or appropriate highway authority.

Recommended dimension and reinforcement specifications for new concrete pads can be found on the standard drawings.

The QuadGuard® II system may be installed on any of the following foundations using the specified anchorage:

#### **Foundation A: Concrete Pad or Roadway**

Foundation: 150 mm [6"] minimum depth Portland Cement Concrete (P.C.C.)

Anchorage: Approved adhesive with 180 mm [7"] studs 140 mm [5 1/2"] embedment

#### **Foundation B: Asphalt over P.C.C.**

Foundation: 76 mm [3"] minimum asphalt concrete (A.C.) over 76 mm [3"] minimum P.C.C.

Anchorage: Length of anchor required is 460 mm [18"] 420 mm [16 1/2"] embedment

#### **Foundation C: Asphalt over Subbase**

Foundation: 150 mm [6"] minimum A.C. over 150 mm [6"] minimum Compacted Subbase (C.S.)

Anchorage: Approved adhesive with 460 mm [18"] studs 420 mm [16 1/2"] embedment

## Foundation D: Asphalt Only

Foundation: 200 mm [8"] minimum A.C.

Anchorage: Approved adhesive with 460 mm [18"] studs - 420 mm [16 1/2"] embedment



**Important:** Systems mounted on asphalt must be replaced and mounted on fresh, undisturbed asphalt if more than 10% of anchors are found to be loose, broken, or show signs of pull out. If 10% or fewer anchors are damaged, replace the damaged anchors in the existing asphalt. Anchor bolts used on systems mounted on asphalt must be inspected every 6 months. See Post Impact Instructions and Maintenance and Repair instructions on page 60.

## Foundation Specifications

For Foundations A, B, C and D mentioned above:

### A. C. (Asphalt Concrete)

AR-4000 A. C. (per ASTM D3381 '83) 3/4" Maximum, Medium (Type A or B) aggregate

Sieve Size	Operating Range (%) Passing
1"	100
3/4"	95-100
3/8"	65-80
No. 4	49-54
No. 8	36-40
No. 30	18-21
No. 200	3-8



**Caution:** Walk-up inspections should be conducted at least once every six months for installations on asphalt.

### P.C.C. (Portland Cement Concrete)

Stone aggregate concrete mix

4000 psi minimum compressive strength

(Sampling per ASTM C31-84 or ASTM C42-84a, testing per ASTM C39-84)

### C.S. (Compacted Subbase)

150 mm [6"] minimum depth 95% compaction

Class 2 aggregate

Sieve Size	Moving Average % Passing
3"	100
2 1/2"	90-100
No. 4	40-90
No. 200	0-25

# Trinity Highway Approved Adhesive Anchoring System

A Trinity Highway approved adhesive anchoring system is required to securely anchor crash cushions. Each approved adhesive kit contains adhesive, studs, nuts, washers and instructions. Both vertical and horizontal assemblies are possible using an approved adhesive anchoring system.

## Vertical Assemblies

**Note:** Read all Trinity Highway approved adhesive instructions before starting.

### 1) Prepare the Concrete Foundation



**Warning:** Do not allow anchoring adhesive to contact skin or eyes. See material safety data sheet supplied with adhesive kit for first-aid procedures. Use only in well-ventilated area. Do not use near open flame.



**Warning:** Wear safety goggles and gloves during construction.

The anchor bolts (studs) that anchor the QuadGuard® II system Backup and/or Monorail sections to the concrete foundation must be those shipped in the kit or of high strength steel (830 MPa [120,000 psi] minimum tensile strength or equal). These studs must be set in minimum 28 MPa [4000 psi] concrete. Allow the concrete to cure a minimum of seven days before applying anchoring adhesive.

### 2) Drill Boreholes

**Note:** Trinity Highway recommends using double-fluted drill bits to achieve optimum tensile strength when using an approved adhesive anchoring system.

Use the part that is to be anchored as a drilling template. Drill the boreholes 3 mm [1/8"] larger than the stud diameter to the recommended depth, using a rotary hammer drill. If a diamond drill bit is used, the surface will be too smooth for the approved adhesive to adhere and full strength will not be achieved. See the approved adhesive instructions provided with your kit. Check to be sure all the boreholes are drilled to the proper depth and aligned with the part to be anchored (see Table A).

**Table A**  
Anchoring Information

Stud Size:	Concrete Bit Size	Minimum Depth	Recommended Torque
3/4"x 6 1/2"	22 mm [7/8"]	125 mm [5"]	Manufacturer Spec
3/4"x 7"	22 mm [7/8"]	140 mm [5" 1/2"]	Manufacturer Spec
3/4"x 18"	22 mm [7/8"]	420 mm [16 1/2"]	15 N-m [10 ft-lb] ⚠



**Important:** When mounting on asphalt, initial torque shall be as shown in Table A. Due to the potential instability of asphalt, anchors may loosen over time. For this reason, anchoring to asphalt should be limited to deployment at temporary locations. It is recommended to re-torque anchors in asphalt every six (6) months to the initial specified torque.

### 3) Clean the Boreholes

Blow the concrete dust from the borehole using oil-free compressed air. Thoroughly brush the borehole with a 7/8" diameter steel bristle tube brush and then blow it out again. If the borehole is wet, completely flush it with water while brushing. The boreholes must be free of debris, dust, water, ice, oil, grease and other contaminants prior to adhesive injection.

### 4) Apply Approved Adhesive

Fill the borehole 1/3 to 1/2 full.



**Caution:** Do not overfill or under-fill the borehole. If the borehole is overfilled, there will not be enough grout to anchor all of the studs provided in the kit. If borehole is underfilled, the grout may not develop the required pull out strength.

### 5) Add the Washers and Nuts

Place a flat washer onto the stud then thread a nut on until **1 or 2 threads of the NUT** are left exposed.

### 6) Insert Studs in Boreholes and Wait for Grout to Harden

Push the stud down through the part to be anchored and into the borehole. Give the stud several twists in the approved adhesive to wet the threads.



**Caution:** Do not disturb or load the stud until the approved adhesive material has hardened (see instructions supplied with the approved adhesive kit).

### 7) Torque the Nuts

Once the grout has hardened, torque the nut to the recommended values (see Table A on p. 15).

## Assembly Cautions

### 1) Steel rebar

If steel rebar is encountered while drilling an anchor bolt borehole, apply one of the following solutions:

- A) Using a diamond core drill bit or rebar drilling tool, drill through the rebar only, then switch back to the concrete bit and drill into the underlying concrete until the proper hole depth is reached.



**Danger:** Do not drill through rebar without first obtaining permission to do so from the project engineer and only per the engineer's instructions.

- B) Drill a new borehole down at an angle past the rebar to the proper depth. Anchor the stud by completely filling both boreholes with an approved adhesive.

## Horizontal Assemblies

The horizontal approved adhesive kit is the same as the vertical kit.



**Caution:** Do not overfill or under fill a borehole. Fill borehole approximately 1/3 to 1/2 full. If the borehole is overfilled, there will not be enough grout to use all of the anchor studs/kit. If borehole is under filled, the grout may not develop the required pull out strength.

### 1) Follow the instructions supplied with your approved adhesive kit

Apply approved adhesive to each anchor per instructions.

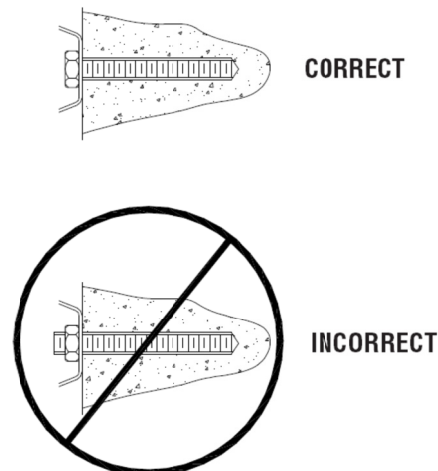
### 2) Add the Washers and Nuts

Put washer and nut on stud, leaving nut flush with end of stud (see Figure 1).

### 3) Insert Studs into Boreholes

Push stud through part to be anchored and into borehole. Twist the stud in the approved adhesive to wet the threads.

**Note:** In horizontal applications the stud should be flush with the top of the nut (see Figure 1).



**Figure 1**  
**Horizontal Application**



**Caution:** Do not disturb or load the stud until the approved adhesive material has hardened (see approved adhesive kit instructions for hardening times).

### 4) Torque the nuts

Once the grout has hardened, torque the nut to the approved adhesive manufacturing spec (see p. 15).



## **Recommended Tools**

### **Documentation**

- Manufacturer's Assembly Manual
- Manufacturer's Drawing Package

### **Cutting Equipment**

- Rotary Hammer Drill
- Rebar Cutting Bit
- Concrete Drill Bits – 22 mm [7/8"] (\*Double-Fluted)
- Grinder, Hacksaw or Torch (optional)
- Drill Bits 1/16" through 7/8"

\* Trinity Highway recommends using double-fluted drill bits to achieve optimum tensile strength when applying an approved adhesive to the anchoring system.

### **Hammers**

- Sledgehammer
- Standard hammer

### **Wrenches**

- Heavy Duty 1/2" drive impact wrench
- 1/2" drive Sockets: 9/16", 11/16", 3/4", 15/16", 1 1/8", 1 1/4"
- 1/2" drive Deep Well Sockets: 15/16", 1 1/4"
- 1/2" drive Ratchet and Attachments
- 1/2" drive Breaker Bar – 24" long
- 1/2" drive Torque Wrench: 200 ft-lb
- Crescent Wrench: 300 mm [12"]
- Allen Wrench: 3/8"

### **Personal Protective Equipment**

- Safety Glasses
- Gloves
- Safety Toe Shoes

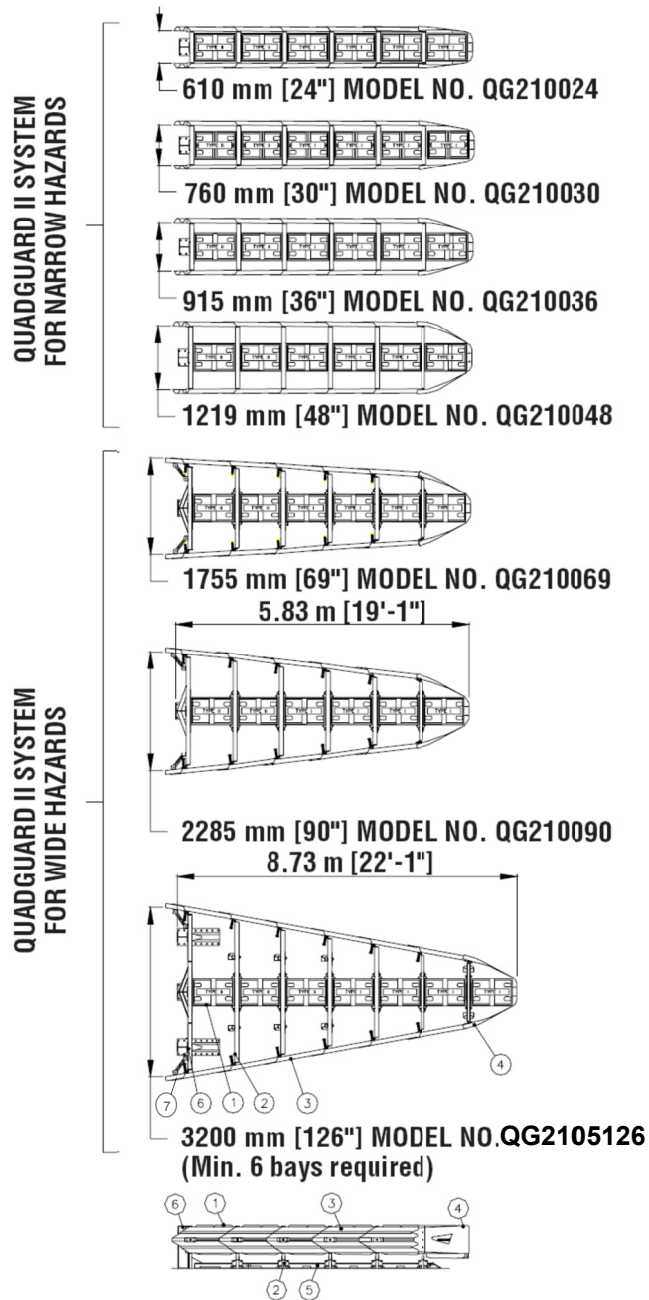


**Important:** Trinity Highway makes no recommendation whether use or reuse of any part of the system is appropriate or acceptable following an impact. It is the sole responsibility of the project engineer and/or the local highway authority and its engineers to make that determination. It is critical that you inspect this product after assembly is complete to make certain that the instructions provided in this manual have been strictly followed.

## Miscellaneous

- Traffic Control Equipment
- Lifting and moving equipment (A lifting device is preferred although a forklift can be used.) Minimum 5,000 lb. capacity required.
- Air Compressor (100 psi minimum) and Generator (5 kW)
- Long Pry Bar
- Drift Pin 300 mm [12"]
- Center Punch
- Tape Measure 7.5 m [25']
- Chalk Line
- Concrete Marking Pencil
- 7/8" Diameter steel tube brush for cleaning drilled boreholes
- Rags, water, and solvent for touch-up

**Note: The above list of tools is a general recommendation and should not be considered an exhaustive list. Depending on specific site conditions and the complexity of the assembly specified by the appropriate highway authority the required tools may vary. Decisions as to what tools are needed to perform the assembly properly are in the sole discretion of the specifying highway authority and the authority's selected contractor performing the assembly of the system at the authority's specified assembly site.**



**Figure 2 Plans & Elevation**  
 (Five Bay systems with Tension Strut Backups shown, except as noted)

Key

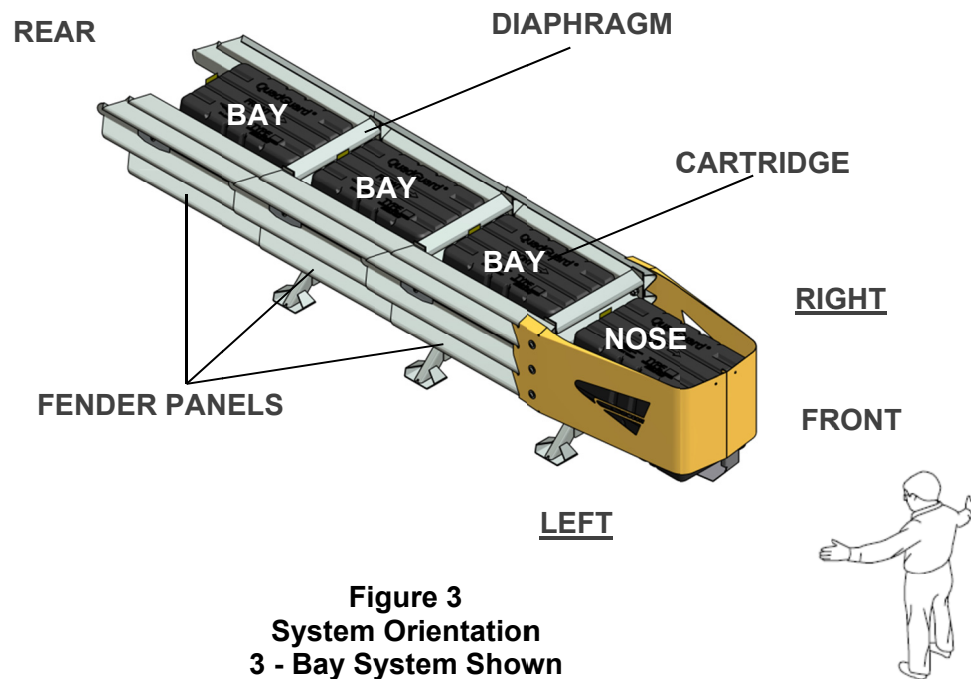
- 1) Cartridge
- 2) Diaphragm
- 3) Quad-Beam™ Fender Panel
- 4) Nose Cover
- 5) Monorail
- 6) Backup
- 7) Side Panel

## How to Determine Left/Right

To determine left from right when ordering parts, stand in front of the system facing the roadside feature. Your left is the system's left and your right is the system's right.

## Counting the Number of Bays

One Bay consists of one Cartridge, one Diaphragm, two Fender Panels, etc. The Nose section is not considered a Bay, though there is a Cartridge in the Nose of each system (see p. 66 & 67 for illustrations). Note that this means there will always be one more Cartridge in the system than the number of Bays in the system. To determine number of Bays, count Fender Panels on one side (see Figure 3). The Three-Bay system is shown below.



**Figure 3**  
**System Orientation**  
**3 - Bay System Shown**

## Measuring the Width

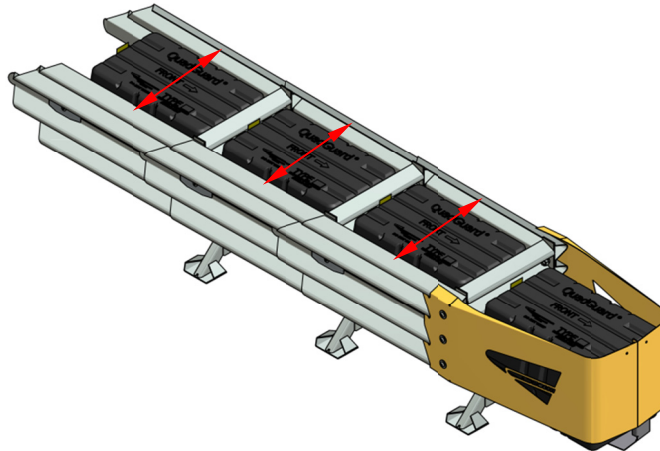
The QuadGuard® II system is available in seven (7) nominal widths:

- 610 mm [24"]
  - 760 mm [30"]
  - 915 mm [36"]
  - 1219 mm [48"]
  - 1755 mm [69"]
  - 2285 mm [90"]
  - 3200 mm [126"]
- (Minimum 3 Bays Required)
- (Minimum 6 Bays Required)

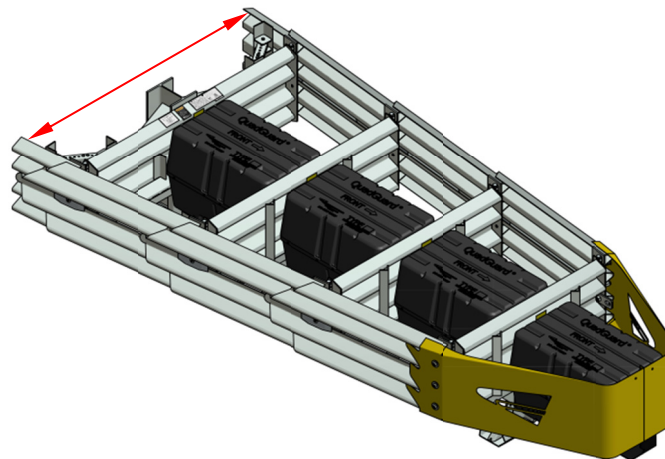
The nominal width of a parallel system is the width of the diaphragm (see Figure 4).

The nominal width of a wide system is the width at the location shown in Figure 5.

The outside width of the system is approximately 150 mm [6"] to 230 mm [9"] wider than the nominal width. The width of the system is not the same as the width of the Backup (see p. 66 & 67 for illustrations).

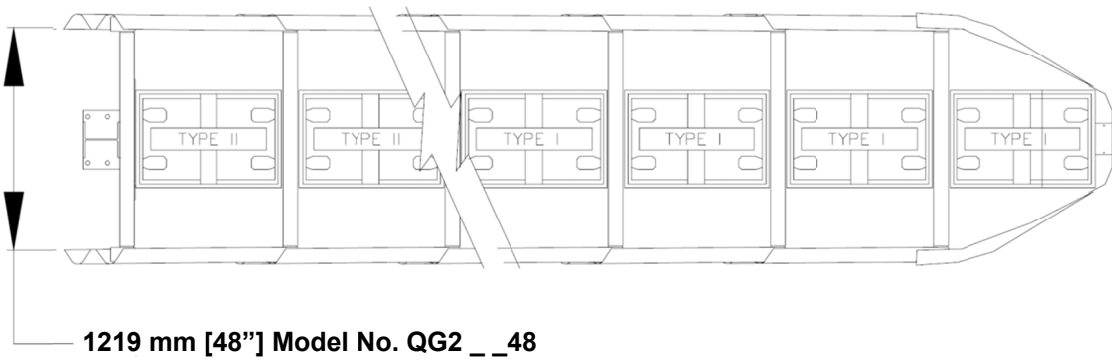
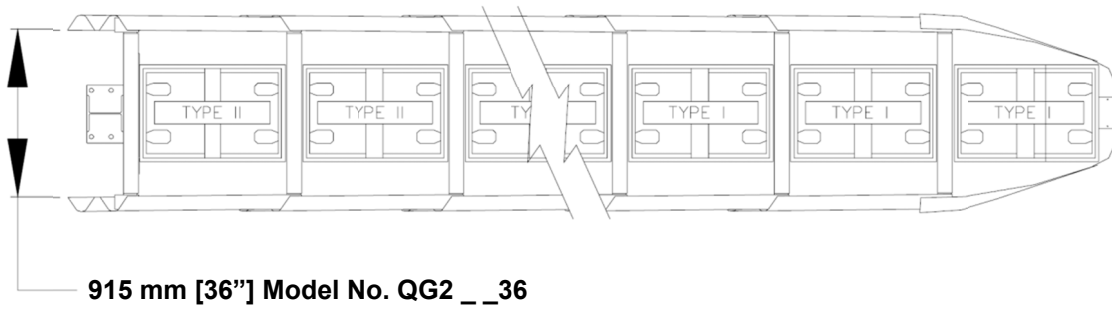
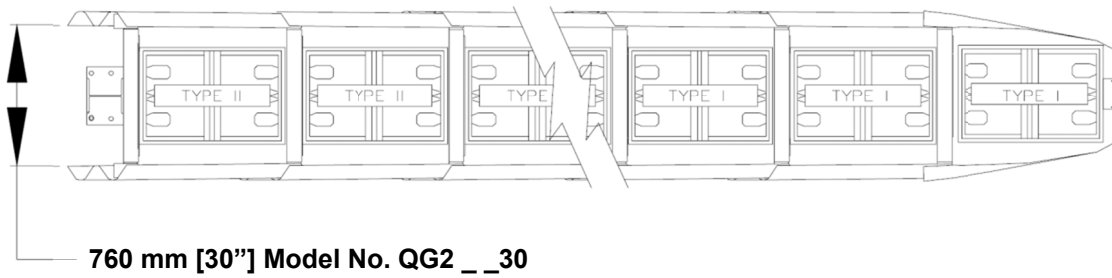
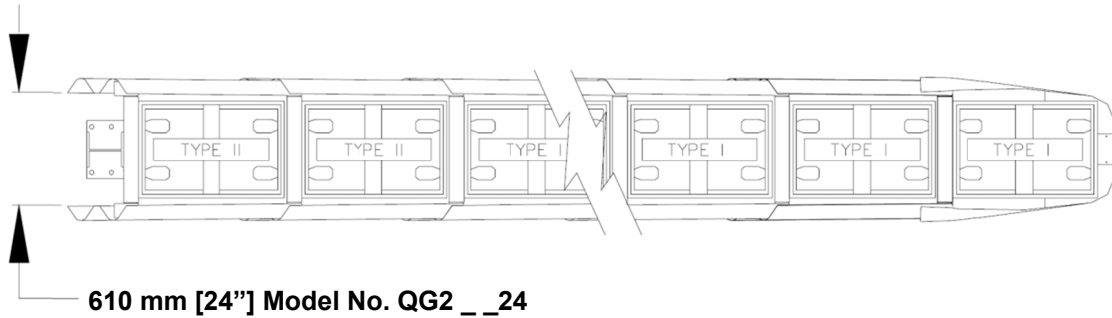


**Figure 4**  
**Width of Parallel system**



**Figure 5**  
**Width of Wide system**

# Narrow Systems



**Figure 6**  
**Narrow System and Model Numbers**

## Site Preparation/Foundation Narrow

A QuadGuard® II system should be assembled only on an existing or freshly placed and cured concrete base (28 MPa [4000 psi] minimum). Location and orientation of the concrete base and attenuator must comply with project plans or as otherwise determined by the local highway authority.

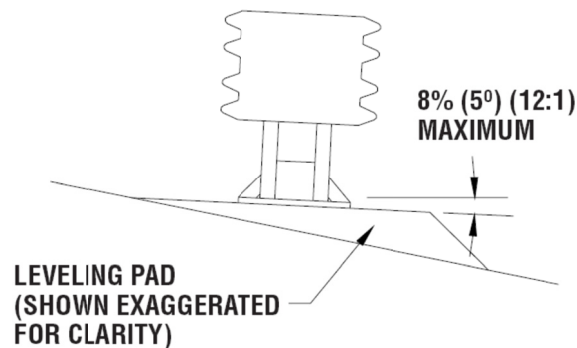
Recommended dimension and reinforcement specifications for new concrete foundations are provided in Trinity Highway concrete foundation drawings, supplied with the system. The system may be assembled on a non-reinforced concrete roadway (minimum 200 mm [8"] thick). Deployment cross-slope shall not exceed 8% and should not twist more than 2% over the length of the system; the foundation surface shall have a light broom finish.



**Warning:** Ensure that there is proper site grading for the QuadGuard® II placement as dictated by the state or specifying agency, pursuant to AASHTO guidelines.



**Caution:** Accurate placement of all steel rebar is critical to avoid interference with the concrete anchor bolts.



**Figure 7**  
**Cross-Slope**



**Warning:** Location of the Backup in relation to nearby objects will affect the operation of the attenuator. Upon impact, the Fender Panels are designed to telescope rearward and extend beyond the rigid Backup as much as 876 mm [34.5"] from their pre-impact location. Position the Backup so that the rear ends of the last Fender Panels are a minimum of 760 mm [30"] forward of objects that would otherwise interfere with movement of the rearmost Fender Panels. Failure to comply with this requirement is likely to result in system performance that has not been crash tested pursuant to NCHRP Report 350 criteria and may also cause component damage which will necessitate maintenance or replacement of the system.



# Assembly Narrow

## Inspect Shipping

Before deploying the QuadGuard® II, check the received parts against the shipping list supplied with the system. Make sure all parts have been received.

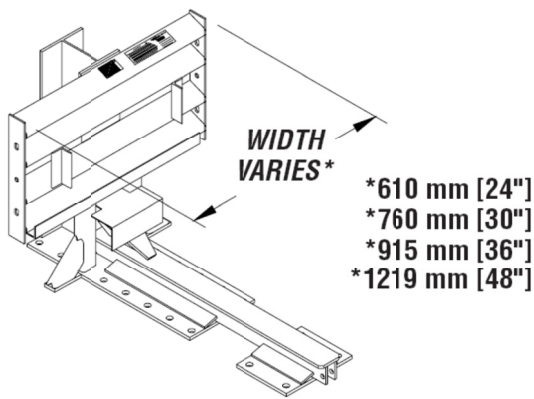


**Important:** The Manufacturer's Drawing Package supplied with the QuadGuard® II must be used with these instructions for proper assembly and should take precedence over these general instructions.

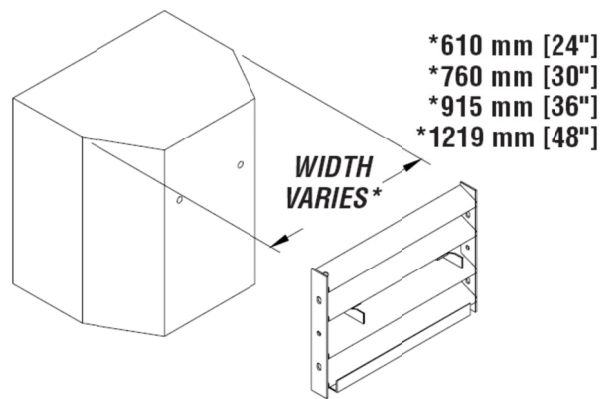
### 1) Determine Backup & Transition Type

The QuadGuard® II is available with a Tension Strut Backup or a Concrete Backup. Refer to Figures 8 and 9, along with the Backup Assembly drawing, to determine which type of Backup is being deployed.

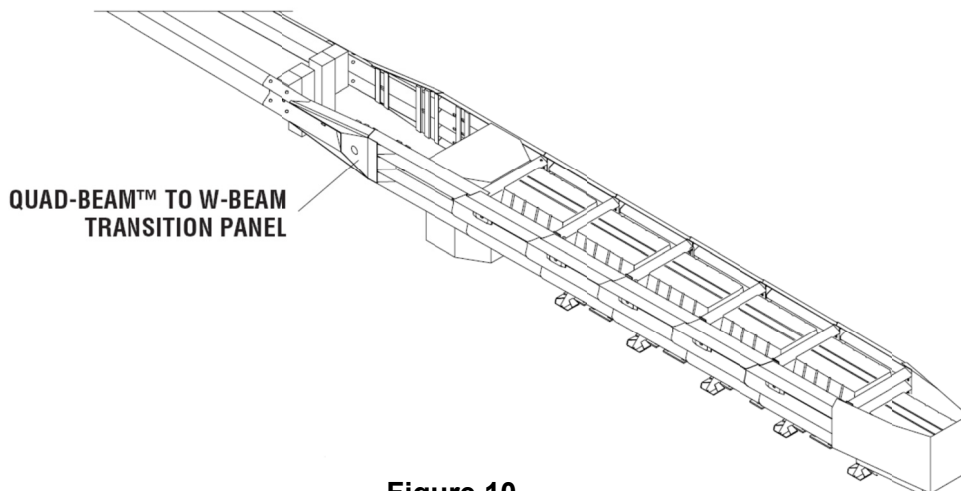
A Transition Panel or Side Panel must be used on each side of the Backup. A Side Panel is not needed when a Transition Panel is used. Several types of Transitions are available for use with the QuadGuard® II. Refer to Figures 10 - 15 and the Manufacturer's Drawing Package to determine which type of Panels to attach.



**Figure 8**  
**Tension Strut Backup**



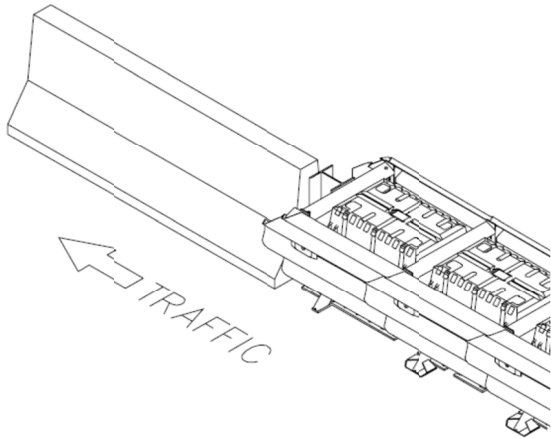
**Figure 9**  
**Concrete Backup**



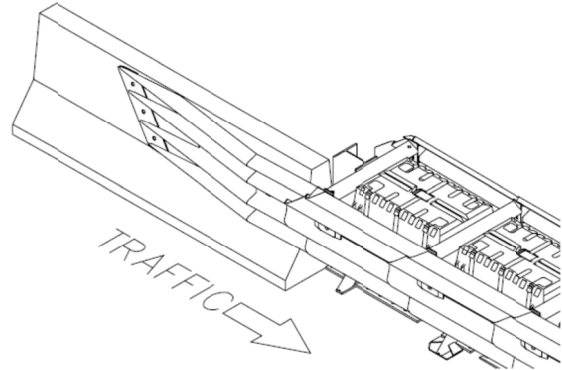
**Figure 10**  
**Transitioning the QuadGuard® II System**

## Transition Panel Types Narrow

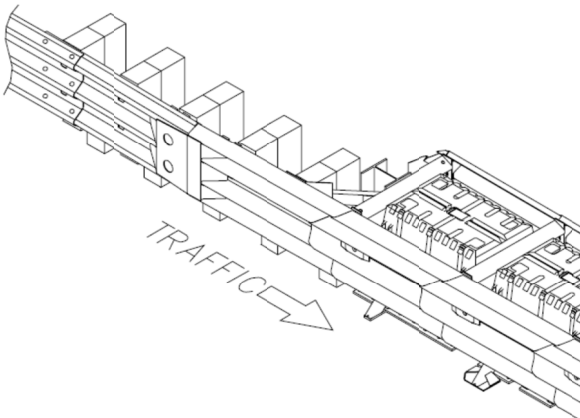
**Note:** The proper Transition Panel or Side Panel must be used for impact performance of the system. The correct Panel(s) to use will depend on the direction of traffic and what type of barrier or roadside obstacle the QuadGuard® II system is shielding. Contact the Customer Service Department prior to deployment if you have any questions.



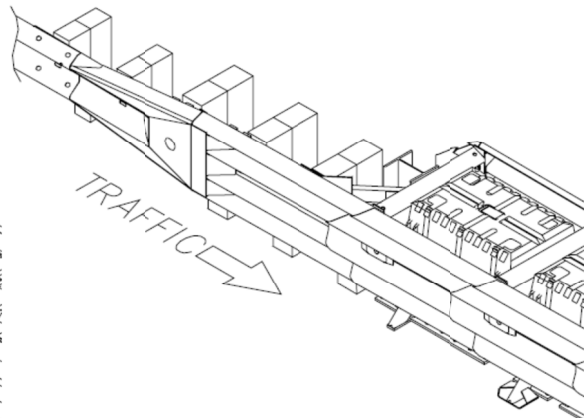
**Figure 11**  
No Transition



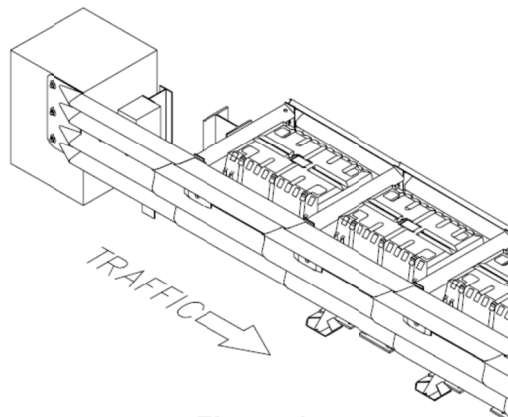
**Figure 12**  
Quad-Beam™ to Safety Shape Barrier  
Transition Panel



**Figure 13**  
Quad-Beam™ to Thrie-Beam  
Transition Panel



**Figure 14**  
Quad-Beam™ to W-Beam  
Transition Panel



**Figure 15**  
Quad-Beam™ End Shoe Transition Panel

## 2) Mark System Location

Locate the centerline of the system by measuring the proper offset from the roadside feature. See the Manufacturer's Drawing Package supplied with the system. Place chalk line to mark the centerline of the system. Mark a construction line parallel to the center line and offset 165 mm [6.5"] to one side as shown in Figure 16. The edge of the Monorail will be positioned on this line.

**Note:** The concrete foundation shall comply with the Manufacturer's Drawing Package supplied with the system.



**Warning:** Location of system with respect to the roadside obstacle is critical and dependent on the type of Transition Panel used. See the Manufacturer's Drawing Package supplied with the system for details.



**Figure 16**  
(Top view of concrete foundation)

## 3) Anchor the Backup

### A) Concrete Backup Construction (Figure 17)

Locate Backup Face Plate using the Backup Assembly drawing. Verify that any applicable Transition Panels fit properly before anchoring the Face Plate. Drill anchor boreholes in the Concrete Backup using the Face Plate as a template. Anchor the Face Plate to the Concrete Backup using an approved adhesive supplied with the QuadGuard® II system (see Approved Adhesive section, p. 15).

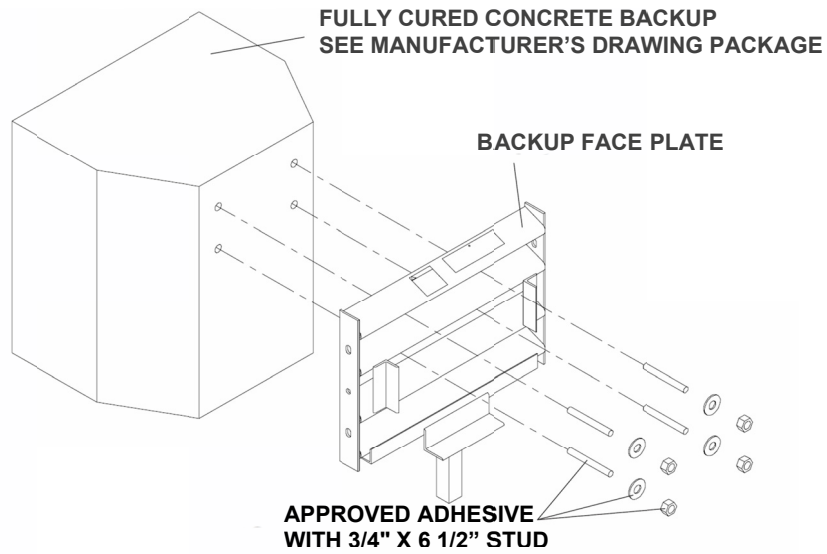
A Trinity Highway approved adhesive anchoring system is required to securely anchor crash cushions and other common highway devices. Each approved adhesive kit contains adhesive, studs, nuts and washers. Both vertical and horizontal assemblies are possible using an approved adhesive anchoring system.



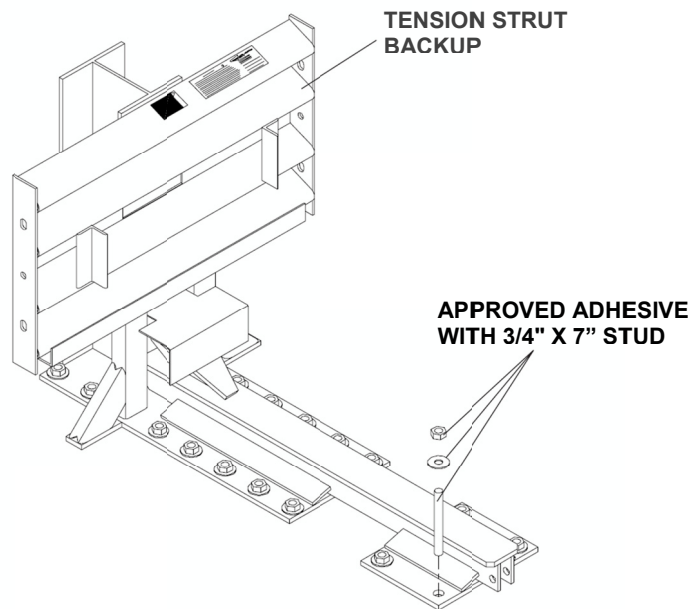
**Warning:** Every borehole and slot in Backup and Monorail must be anchored by a stud using an approved adhesive.

### B) Tension Strut Backup Assembly (Figure 18)

Locate Tension Strut Backup and Monorail on foundation with side of Monorail on the construction line (see Figure 21 on p. 30). Verify that any applicable Transition Panels fit properly before anchoring Backup. Drill anchor boreholes in foundation using the Backup as a template. Anchor the Backup to the concrete foundation using an approved adhesive supplied with the QuadGuard II system (see Approved Adhesive section, p. 15).



**Figure 17**  
**Anchoring Backup Face Plate to**  
**Concrete Backup**



**Figure 18**  
**Anchoring Tension Strut Backup**  
**to Foundation**

#### 4) Anchor the Monorail

##### A) Monorail Construction for Concrete Backup (Figure 19)

Locate Monorail on foundation with side of Monorail on the construction line and rear edge of Monorail foot 10" forward of front face of Concrete Backup (see Figure 19).

Orient the Monorail so that the Monorail tongues face Backup (see Figure 19).

Drill 140 mm [5 1/2"] deep anchor boreholes using the Monorail as a template. Do not drill through foundation.

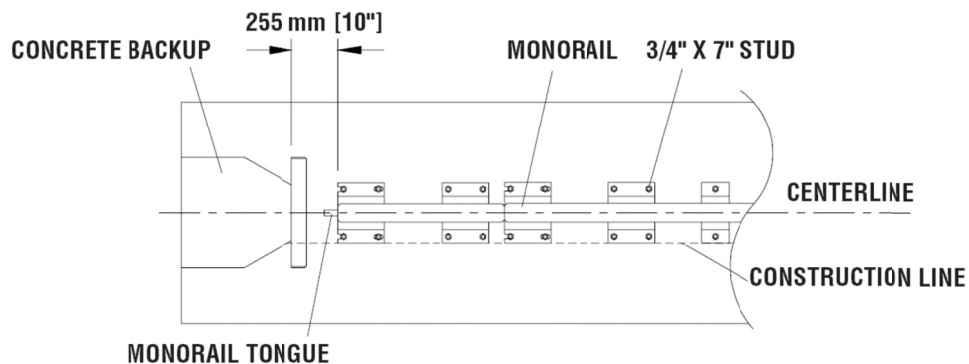


**Warning:** Improper alignment at the Monorail Sections will prevent proper system collapse during impact.

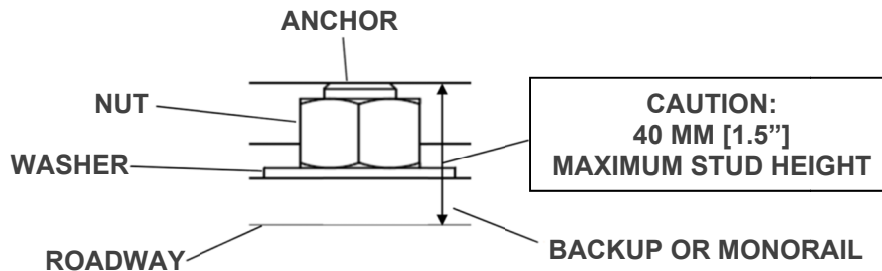
Anchor each Monorail section using an approved Trinity Highway adhesive kit. See Figure 19 and the approved adhesive instructions included with the adhesive kit. It is important to attach each segment of Monorail in alignment from the back to the front of the system ( $\pm 6$  mm [1/4"]).



**Warning:** Every borehole and slot in Backup and Monorail must be anchored by a stud using an approved adhesive.



**Figure 19**  
**Monorail Location for Concrete Backup**



**Figure 20**  
**Proper Stud Height**

## B) Monorail Construction for Tension Strut Backup (Figure 20)

Locate Monorail on foundation with side of Monorail on the construction line and rear edge of Backup foot 4" forward of edge of foundation (see Figure 21).

Orient the Monorail so that the Monorail tongues face the Backup (see Figure 21).

Drill 140 mm [5 1/2"] deep anchor boreholes using the Monorail as a template. Do not drill through foundation.

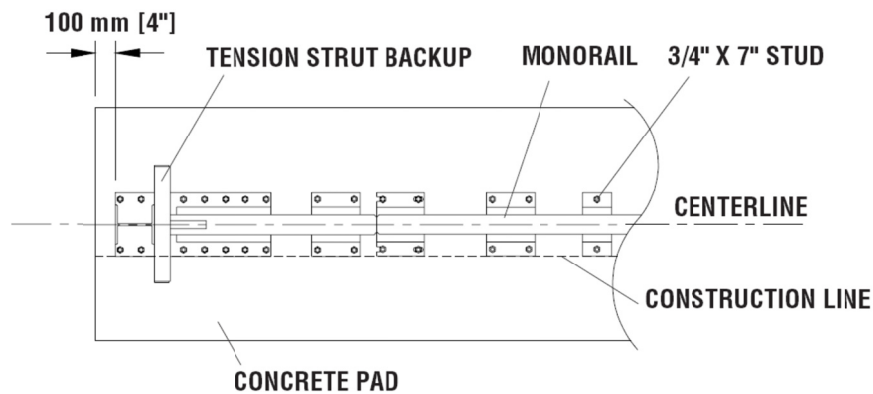


**Warning:** Every borehole and slot in Backup and Monorail must be anchored by a stud using a Trinity Highway approved adhesive.

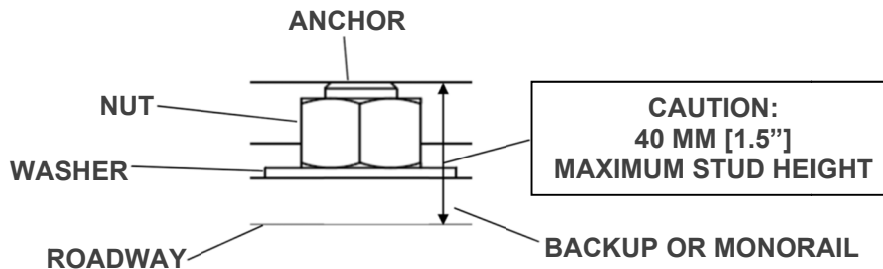
Anchor each Monorail section using the Trinity Highway approved adhesive kits provided. See Detail 20a and the approved adhesive instructions included with each kit. It is important to attach each segment of Monorail in alignment from the back to the front of the system ( $\pm 6$  mm [1/4"]).



**Warning:** Improper alignment at the Monorail splice joints will prevent proper system collapse during an impact.



**Figure 21**  
Backup and Monorail Location for Tension Strut Backup



**Detail 21a**  
Proper Stud Height

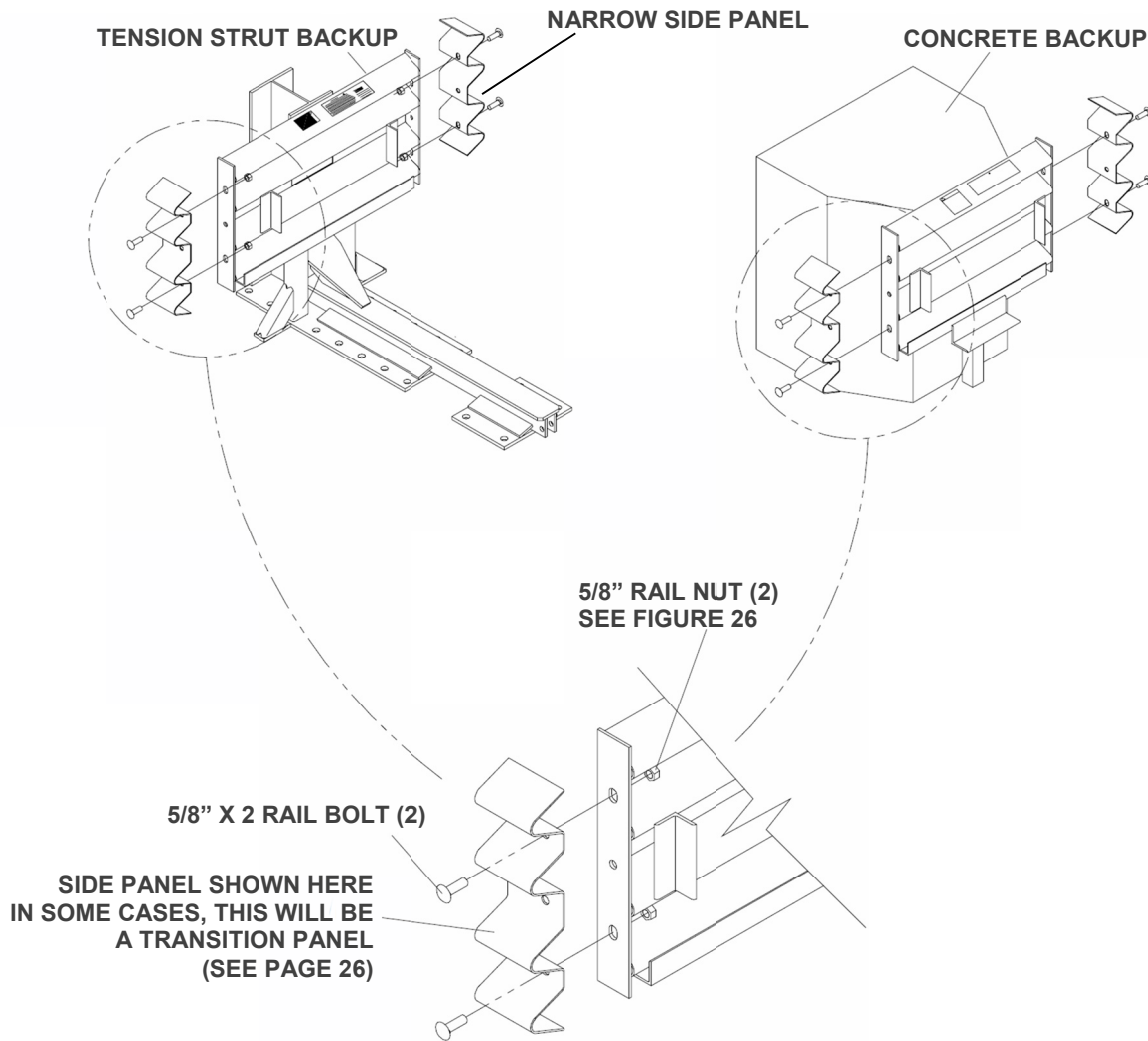
**5) Attach Side Panels and/or Transition Panels to Backup Assembly**

Attach Transition Panel or Side Panel to side of Backup using 5/8" hex bolt and 5/8" rail nut (two places - top and bottom holes only). See Backup Assembly drawing(s) below.

**Note:** A Side Panel is not needed when a Transition Panel is used.

**Assembly tip:**

Use drift pin to align the center hole of the Panel with the center hole of the Backup before inserting the rail bolts.



**Figure 22**  
**Side Panel/Transition Panel Attachment**



## 6) Attach Monorail Guides

Attach Monorail guides to Diaphragm as follows:

Insert 3/4" x 2" G8 hex bolt through Monorail guide and Diaphragm, oriented as shown in Figure 23. Secure with 3/4" lock washer and 3/4" hex nut (typical 4 places). See also Diaphragm Assembly drawing. Shims are sandwiched between the Rail Guide and Diaphragm.

Repeat process for each Diaphragm.

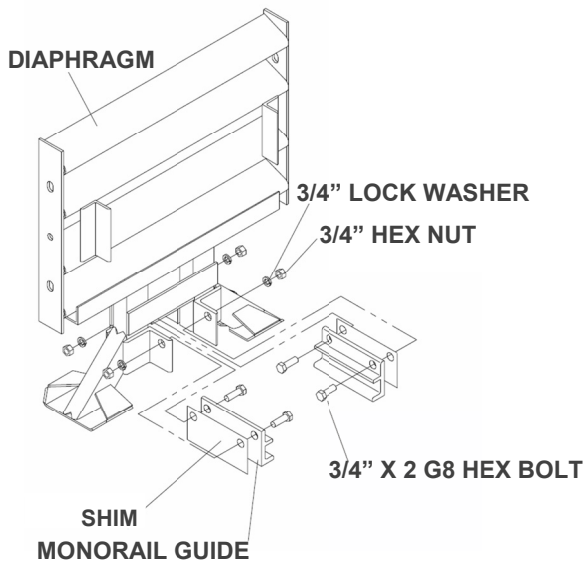
## 7) Attach Diaphragms

Orient a Diaphragm so that the front face of the Diaphragm shape faces toward the Nose of the system as shown in Figure 24.

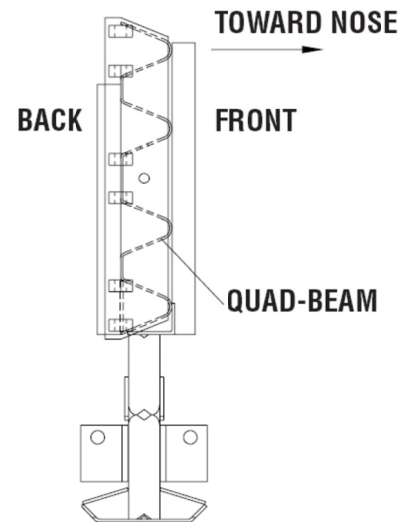


**Important:** Slide one Diaphragm all the way to the Backup to ensure the system is able to collapse properly during impact. Once this has been verified, slide the Diaphragm to approximately 915 mm [36"] in front of the Backup

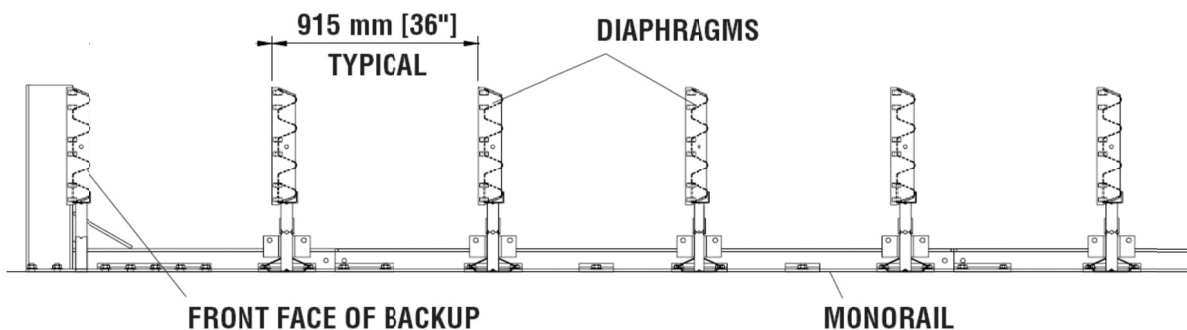
Orient and slide all other Diaphragms onto Monorail and position each approximately as shown in Figure 25.



**Figure 23**  
**Monorail Guide Attachment**



**Figure 24**  
**Diaphragm Orientation**

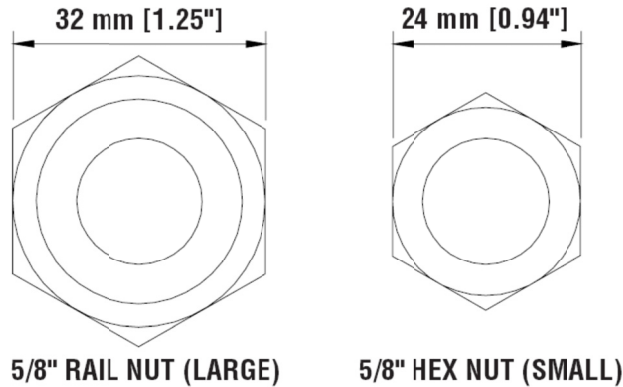


**Figure 25**  
**Diaphragm Spacing**

## 8) Attach Fender Panels



**Important:** Do not mix the 5/8" rail nuts (large) with the 5/8" hex nuts (small) (see Figure 26).



**Figure 26**  
**Rail Nuts are Oversize**

Starting at the Backup, attach left and right Fender Panels shown on page 31 and Fender Panel Assembly drawing.

### **Step 1**

Place the Fender Panel so that the center of the slot of the rearward Diaphragm is lined up with the approximate center of the slot in the Fender Panel.

Attach Mushroom Washer Assembly as shown in Figure 27 and Detail 27a and Detail 26b, but do not torque at this time. This (Step 1) helps to balance the Fender Panel.

### **Step 2**

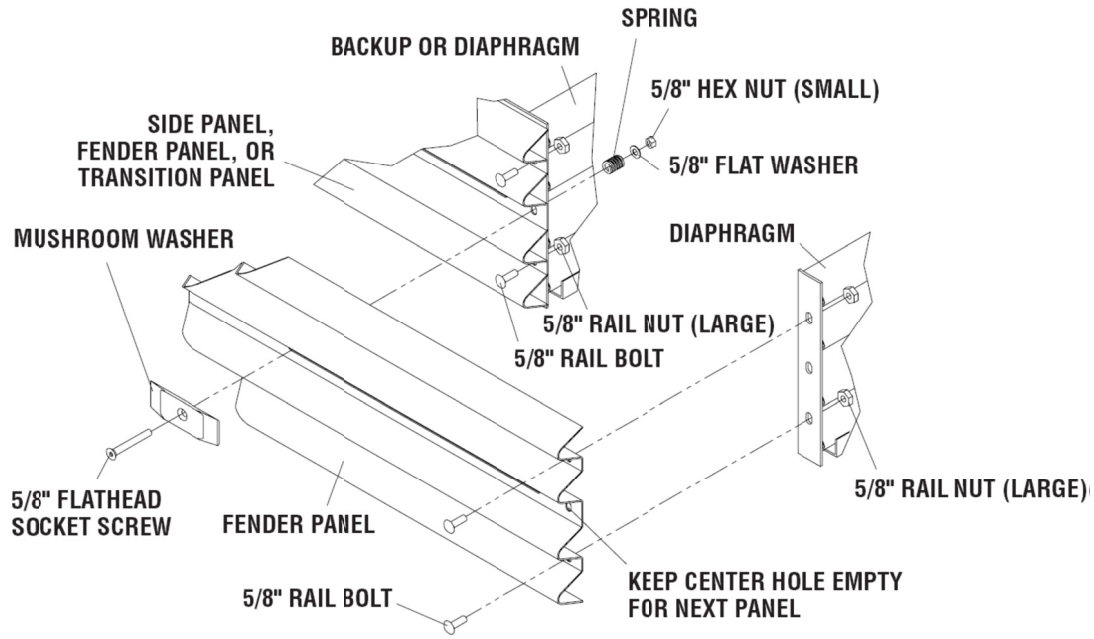
Slide the Fender Panel forward until the holes in the Fender Panel line up with the holes in the forward Diaphragm.

### **Step 3**

Use a drift pin to align the center hole of the Fender Panel with the center hole of the Diaphragm.

### **Step 4**

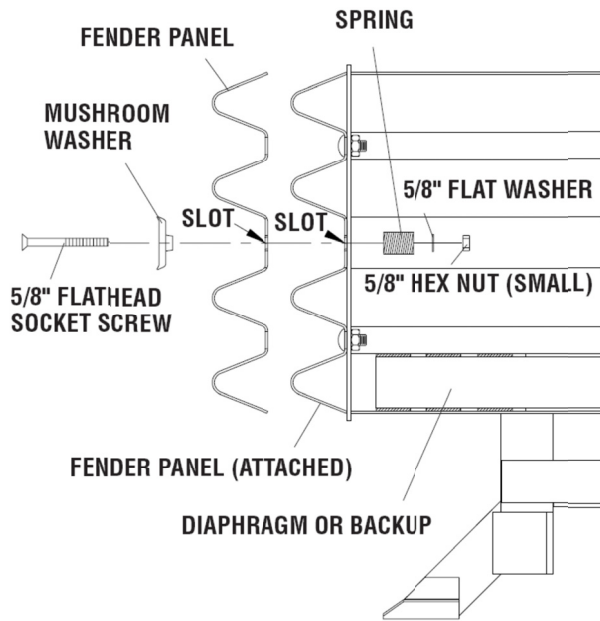
Attach the front of the Fender Panels to the next Diaphragm using two (2) rail bolts and large hex nuts per side. Use only the top and bottom holes; leave the center hole open until the next Fender Panel is attached.



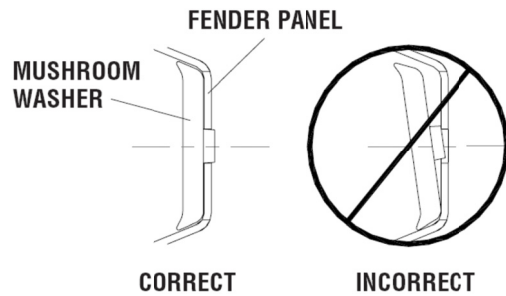
**Figure 27  
Fender Panel Assembly**

**Step 5**

Ensure Mushroom Washer lays flat against the Fender Panel as shown in Figure 27b. Standoff on Mushroom Washer must be seated completely through slot.



**Detail 27a  
Mushroom Washer Attachment**



**Detail 27b  
Mushroom Washer Orientation**

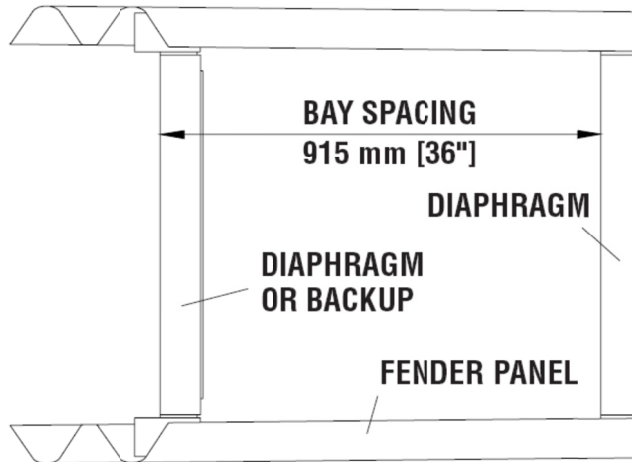
**Step 6**

Check Diaphragm spacing to ensure 915 mm [36"] between rear faces of consecutive Diaphragms, as shown in Figure 28 and Fender Panel Assembly drawing.

**Step 7**

Once proper spacing has been achieved, torque the Mushroom Washer Assembly (small hex) nut until it reaches the end of the threads.

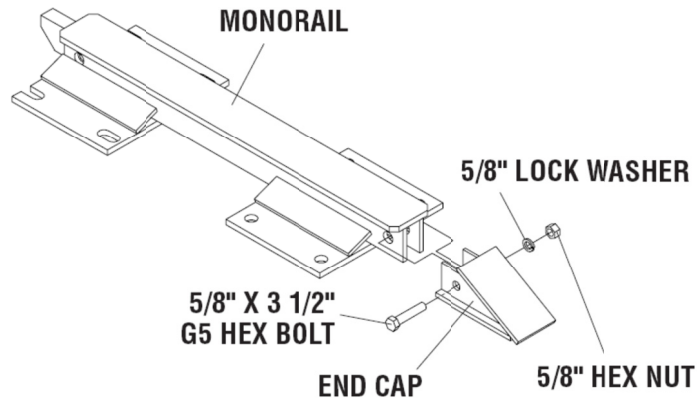
Assemble the remaining Diaphragms and Fender Panels following the same procedures.



**Figure 28**  
**Proper Diaphragm Spacing**

**9) Attach End Cap**

Using 5/8" x 3 1/2" G5 hex bolt, 5/8" hex nut and 5/8" lock washer, attach the End Cap to the front of the first Monorail segment, as shown in Figure 29 and Monorail Assembly drawing.

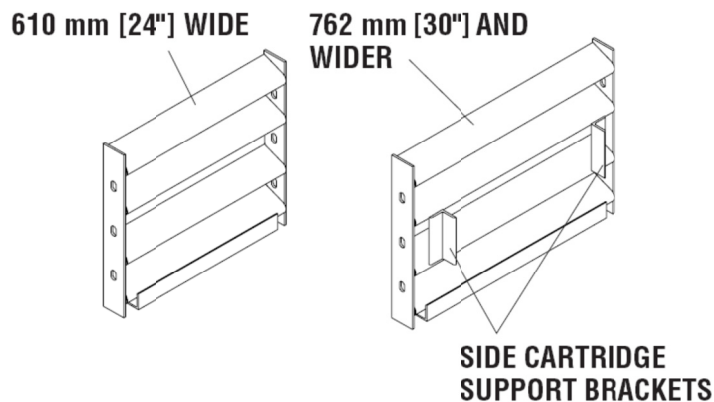


**Figure 29**  
**Monorail End Cap Assembly**

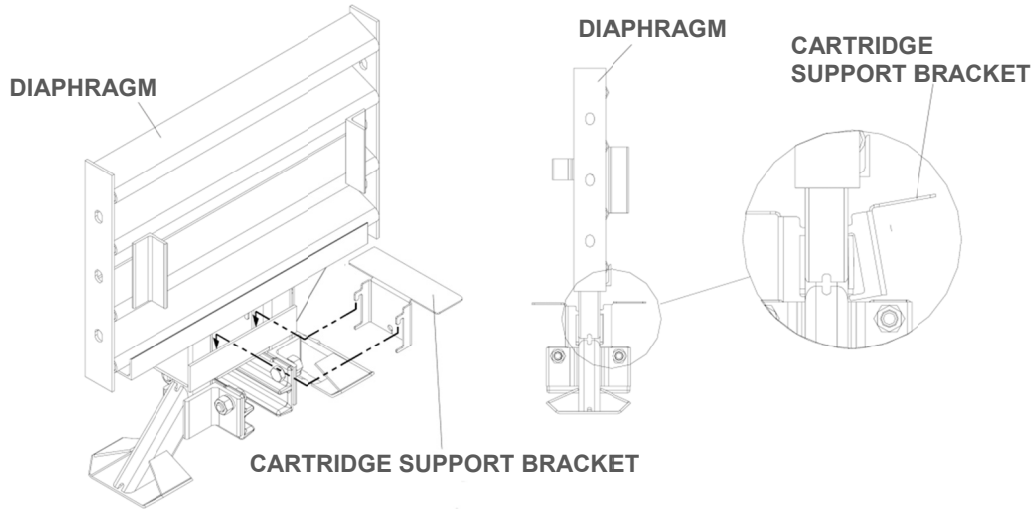
**10) Attach Cartridge Support Brackets**

Attach lower Cartridge Support Bracket to front and back of all Diaphragms and front of Backup, as shown in Figures 31 to 33 Diaphragm Assembly drawings, and Backup Assembly drawings.

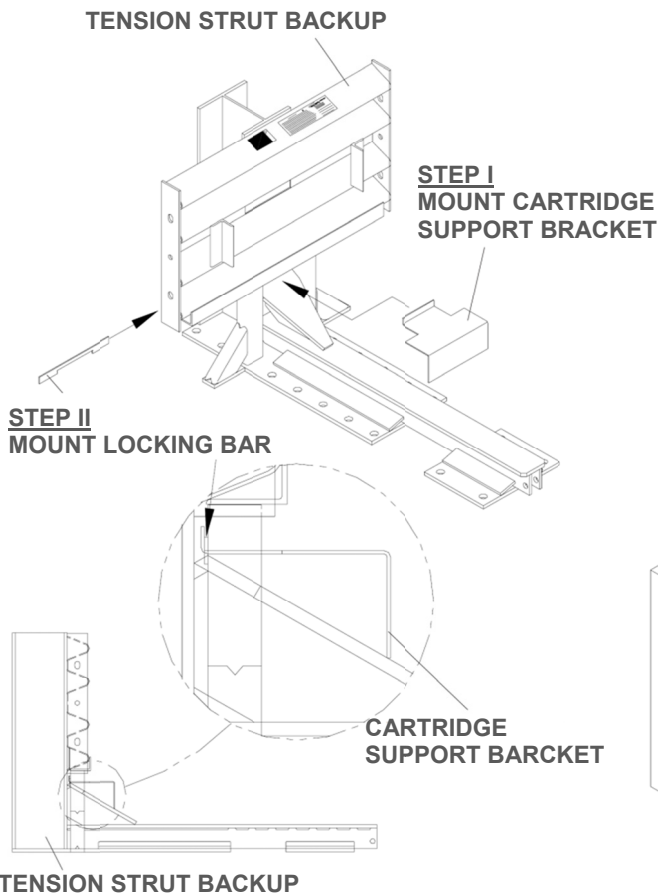
**Note:** 610 mm [24"] wide systems do not have Side Cartridge Support Brackets: 762 mm [30"], 914 mm [36"] and 1219 mm [48"] wide systems have Side Cartridge Support Brackets welded to the Backup and Diaphragms.



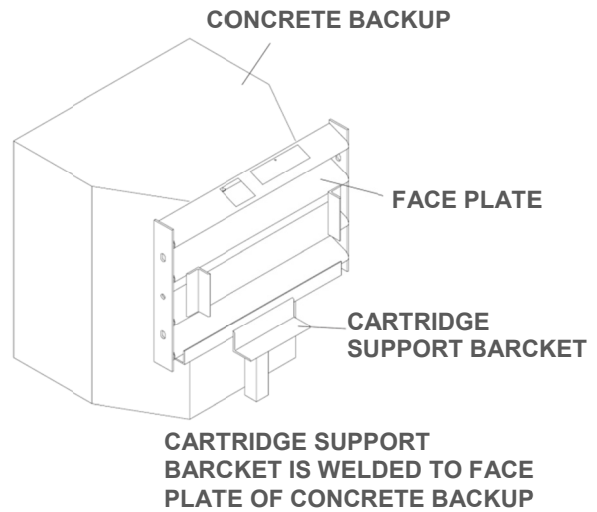
**Figure 30**  
**Side Cartridge Support Brackets**



**Figure 31**  
**Lower Cartridge Support Bracket Assembly**



**Figure 32**  
**Lower Cartridge Support Bracket Assembly**  
**(Tension Strut Backup)**

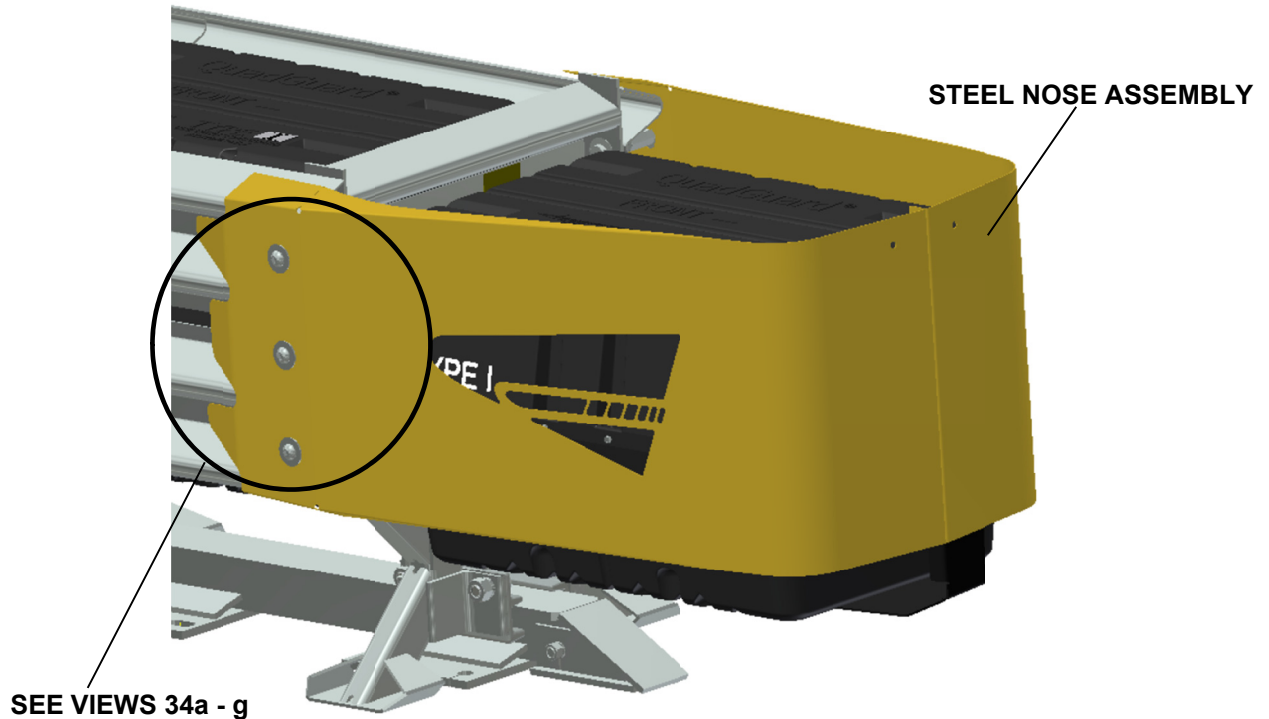


**Figure 33**  
**Lower Cartridge Support Bracket**  
**(Concrete Backup)**

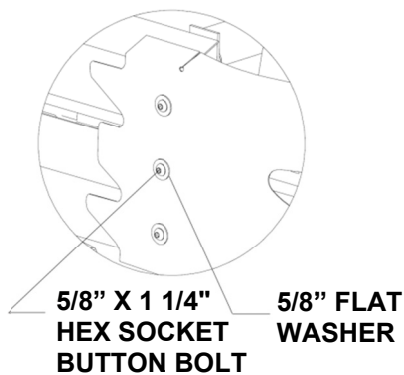
**11) Attach Nose Assembly**

Bolt the Nose directly to the front Diaphragm, as shown in Figures 34a through 34c and the Nose Assembly drawing.

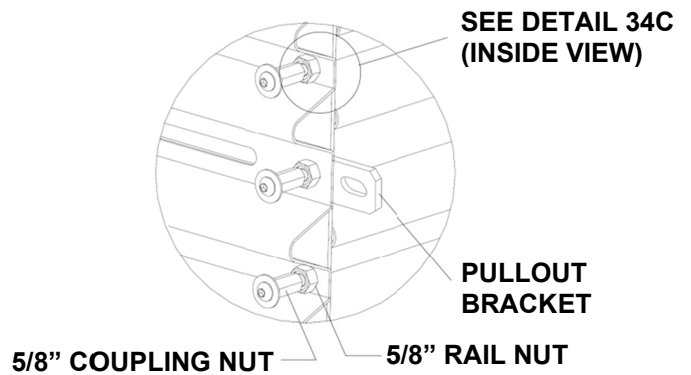
Place Pullout Brackets under center bolts.



**Figure 34**

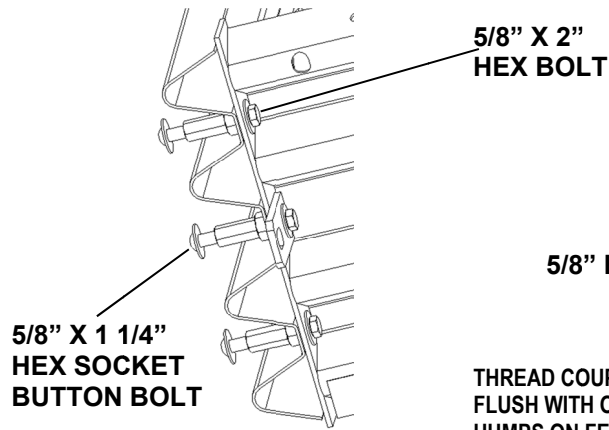


**Detail 34a  
Fastener Assembly**

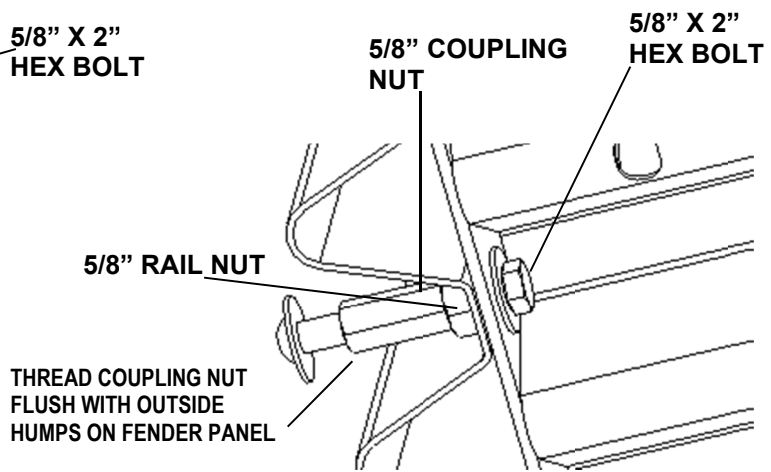


**Detail 34b  
Steel Nose not shown for Clarity**

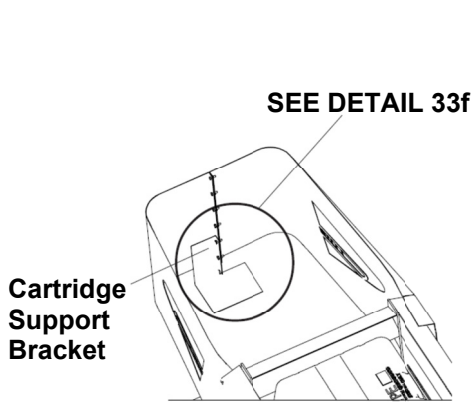




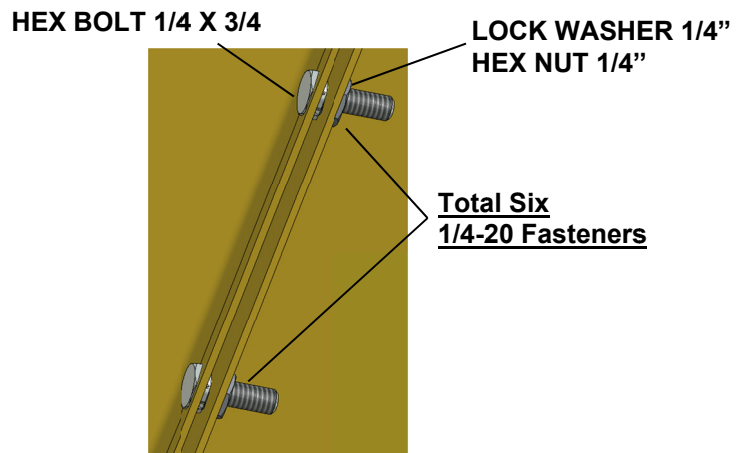
**Detail 34c**  
End View Without Nose Cover



**Detail 34d**  
End View: Nose Cover Cut Away

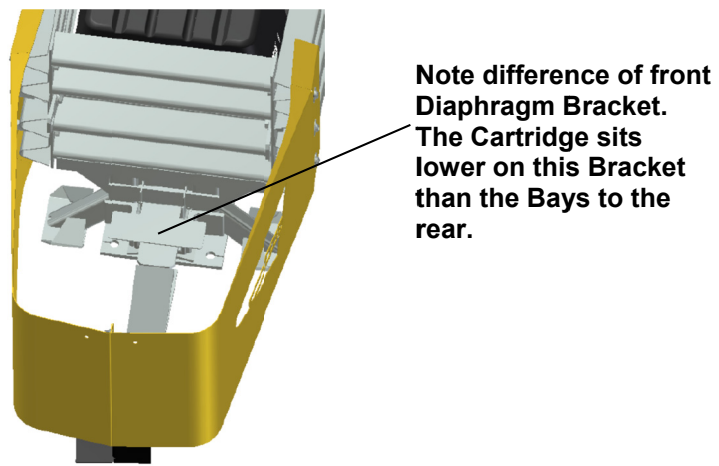


**Detail 34e**



**Detail 34f**

Detail 33f shows proper placement of front Cartridge Support Bracket.



**Detail 34g**

## 12) Checking the System Assembly

Recheck to ensure that all fasteners are properly tightened throughout the system (anchor bolts, etc.). See torque requirements below. Check all Fender Panels. If they do not fit tightly against the underlying Fender Panel, system realignment may be necessary (see Figure 35).



**Warning:** Ensure that the QuadGuard® II system and delineation used meet all federal, state, specifying agency, and local specifications.



**Warning:** Ensure delineation on the assembly meets all appropriate MUTCD and local standards.



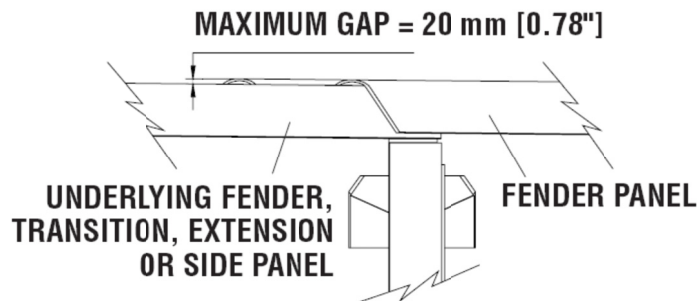
### Warning:

#### Bolt Torque Requirements

Anchor Studs – see Table A, p. 15  
May slightly protrude above nuts

#### Critical Clearances

Anchor Studs above nuts – see Figure 20, p. 29  
Fender Panel Gap Narrow – 20 mm [0.78"] see below



**Figure 35**  
**Fender Panel Gap for Narrow Systems**

## 13) Cartridge Assembly

Be sure the Adjustable Cartridge Support in the Nose is attached correctly. See “Attach Nose Assembly” on page 38. The top surface of the Nose Cartridge should be horizontal.

To complete the assembly of a QuadGuard® II system, place the appropriate Cartridge in each Bay and Nose section of the system. Type 1 Cartridges are placed toward the front (Nose) of the system; Type 2 Cartridges are placed toward the rear (Backup) of the system (see Figures 36 and 37).



**Warning:** Placing the wrong Cartridge in the Nose or any Bay will result in system performance that has not been crash tested pursuant to the NCHRP Report 350 criteria.

I - TYPE I CARTRIDGE  
II - TYPE II CARTRIDGE

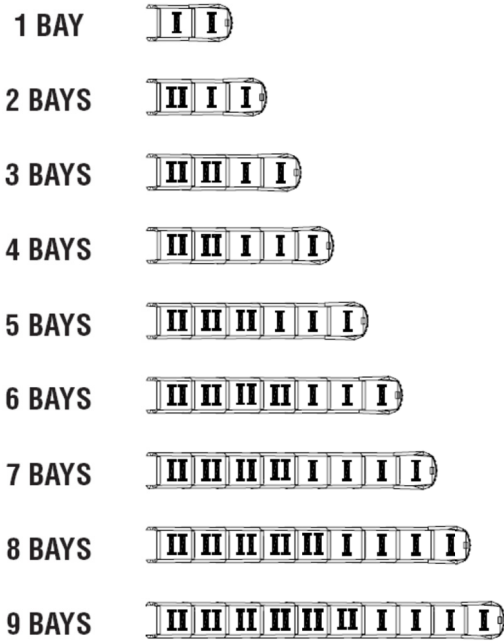


Figure 36  
Cartridge Placement

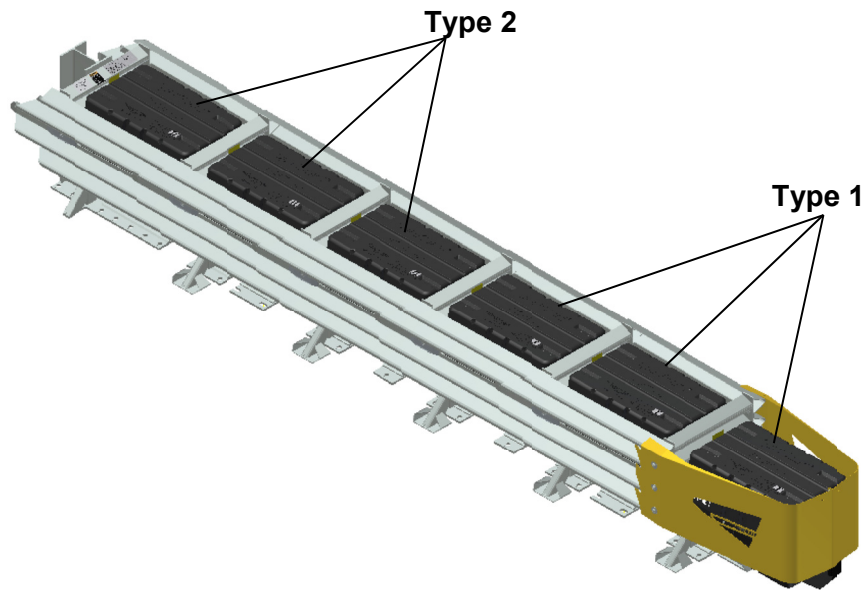
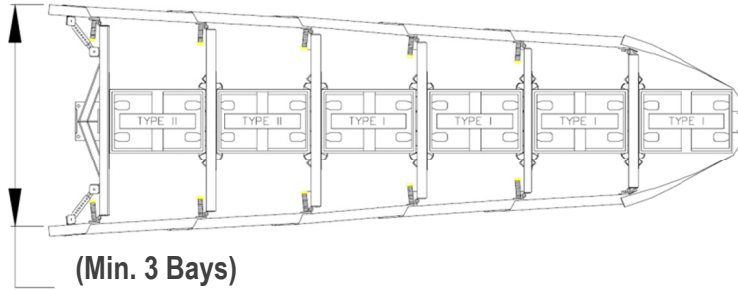
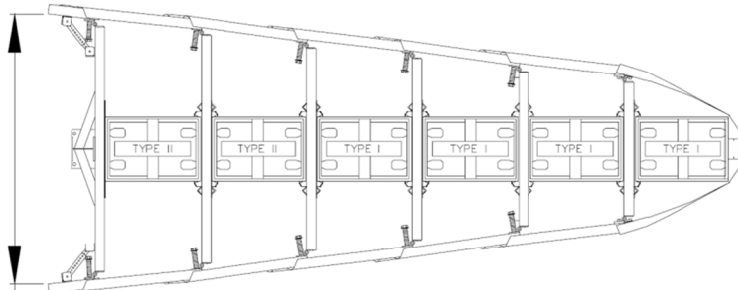


Figure 37  
Typical Cartridge Layout 5 Bay System Shown

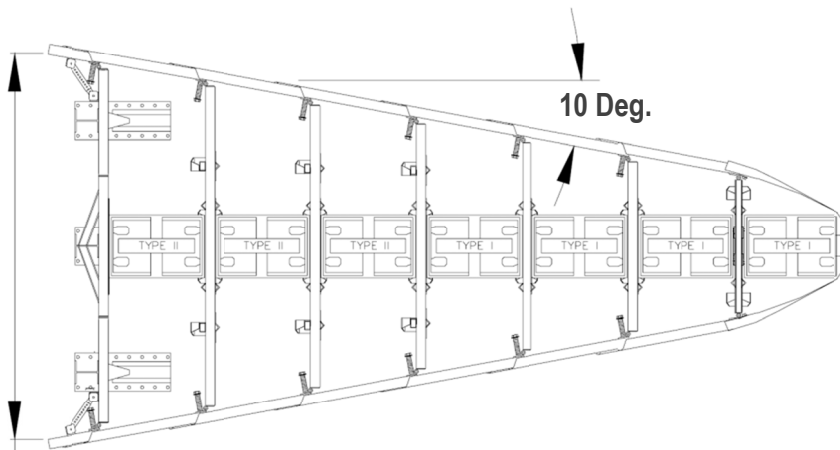
# Wide Systems



(Min. 3 Bays)  
1755 mm [69"] Model No. QG2 \_\_ 69



(Min. 3 Bays)  
2285 mm [90"] Model No. QG2 \_\_ 90



Varies - (Min. 6 Bays)  
3200 mm [126"] Model No. QG2 \_\_ 126

**Figure 38**  
**Wide Systems and Model Numbers**

## Site Preparation/Foundation Wide

A QuadGuard® II system should be constructed only on an existing or freshly placed and cured concrete base (28 MPa [4000 psi] minimum). Location and orientation of the concrete base and attenuator must comply with the Manufacturer's Drawing Package supplied with the system and the project plans specified by the local highway authority.

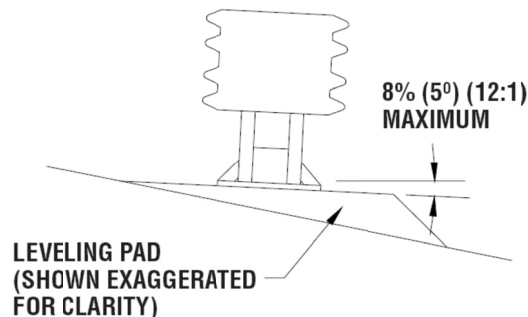
Recommended dimension and reinforcement specifications for new concrete foundations are provided in the Manufacturer's Drawing Package supplied with the system. The system may be assembled on a non-reinforced concrete roadway (minimum 200 mm [8"] thick). Deployment cross-slope shall not exceed 8% and should not twist more than 2% over the length of the system (see Figure 39). The foundation surface shall have a light broom finish.



**Warning:** Ensure that there is proper site grading for the QuadGuard® II system placement as dictated by the state or specifying agency, pursuant to AASHTO guidelines.



**Caution:** Accurate placement of all steel rebar is critical to avoid interference with the concrete anchor bolts.



**Figure 39**



**Warning:** Location of the Backup in relation to nearby objects will affect the operation of the attenuator. Upon impact, the Fender Panels telescope rearward and extend beyond the rigid Backup as much as 876 mm [34.5"] from their pre-impact location. Position the Backup so that the rear ends of the last Fender Panels are a minimum of 760 mm [30"] forward of objects that would otherwise interfere with movement of the rearmost Fender Panels. Failure to comply with this requirement is likely to result in system performance that has not been crash tested pursuant to NCHRP Report 350 criteria and may also cause component damage which will necessitate maintenance or replacement of the system.

# Assembly Wide

## Inspect Shipping

Before deploying the QuadGuard® II system, check the received parts against the shipping list supplied with system. Make sure all the parts have been received.

## Assembly Procedures

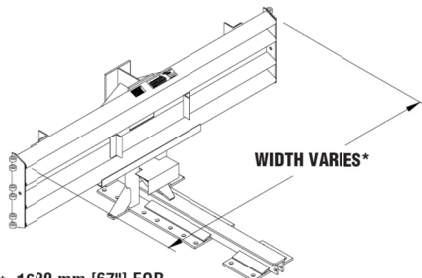


**Important:** The Manufacturer's Drawing Package supplied with the QuadGuard® II system must be used with these instructions for proper assembly and should take precedence over these general instructions.

### 1) Determine Backup and Transition Type

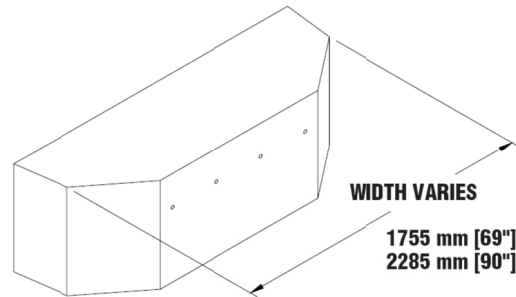
The QuadGuard® II is available with a Tension Strut Backup or a Concrete Backup. See Figures 40 and 41, along with the Backup assembly drawing, to determine which type of Backup is being deployed.

A Transition Panel or Side Panel must be used on each side of the Backup. A Side Panel is not needed when a Transition Panel is used. Several types of transitions are available for use with the QuadGuard® II system. See Figures 43 through 47 and the Manufacturer's Drawing Package to determine which types of Fender Panels to attach.

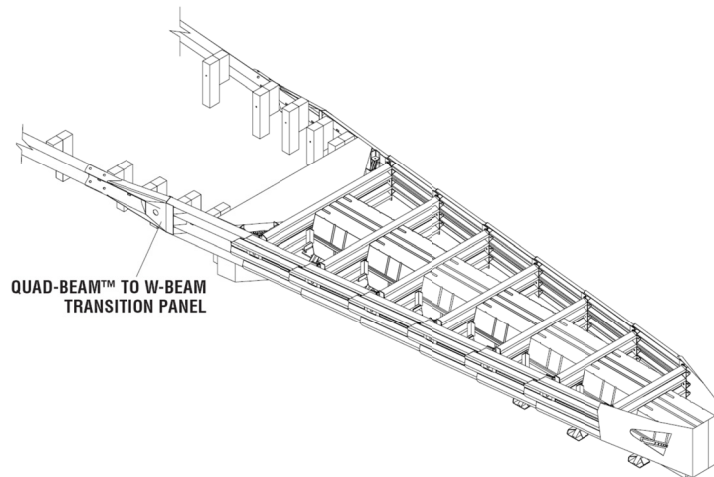


- \* 1620 mm [67"] FOR
- 1755 mm [69"] WIDE SYSTEM
- \* 2100 mm [83"] FOR
- 2235 mm [90"] WIDE SYSTEM
- \* 3050 mm [120"] FOR
- 3200 mm [126"] WIDE SYSTEM

**Figure 40**  
Tension Strut Backup



**Figure 41**  
Concrete Backup



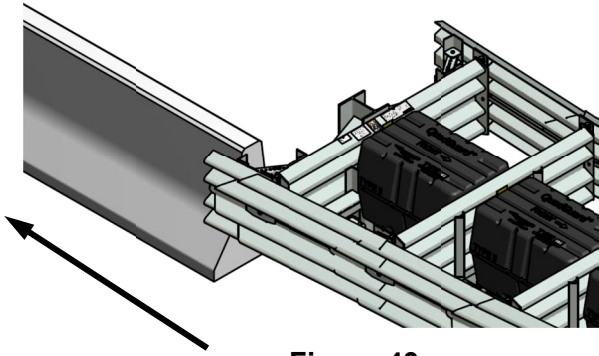
**Figure 42**  
Transitioning the QuadGuard® II System



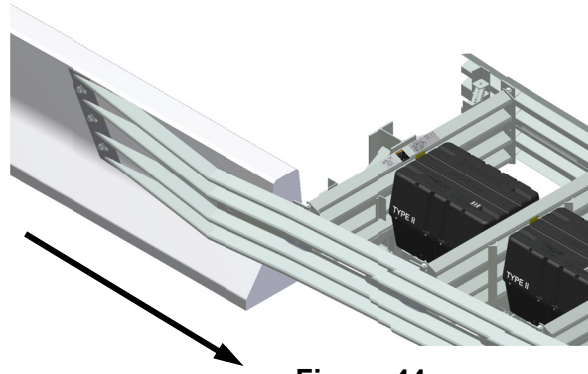
## Transition Panel Types Wide



**Important:** The proper Transition Panel or Side Panel must be used to perform as crash tested. **The correct Panel(s) to use will depend on the direction of traffic and what type of barrier or roadside obstacle the QuadGuard® II system is shielding.** Contact the Customer Service Department prior to deployment if you have any questions.

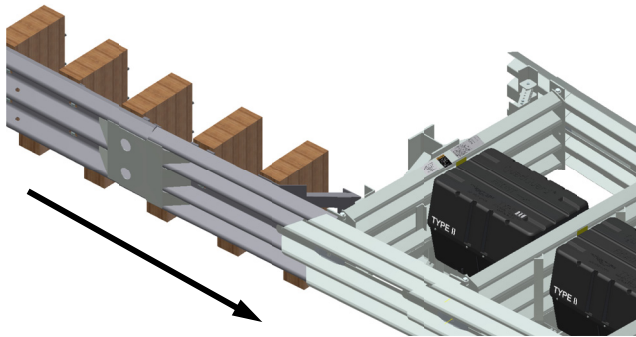


**Figure 43**  
No Transition

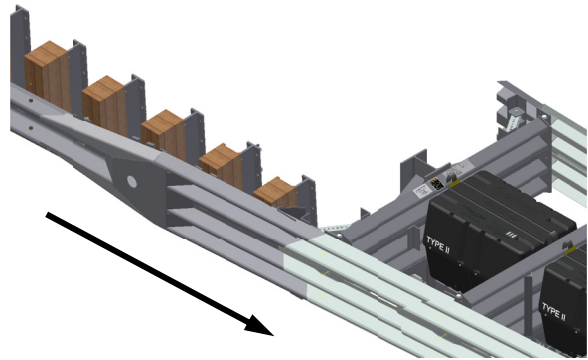


**Figure 44**  
Quad-Beam™ to Safety Shape Barrier  
Transition Panel

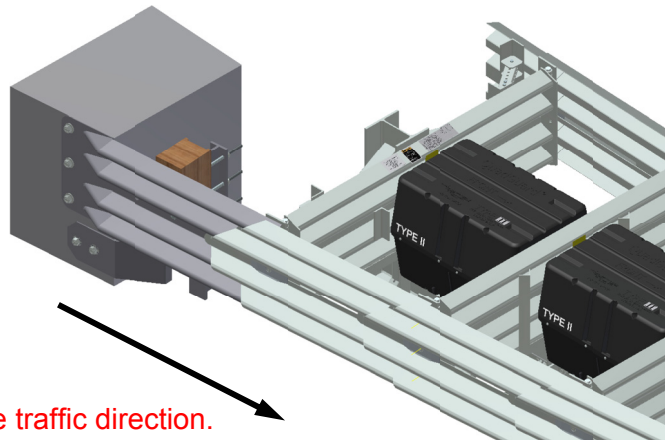
**Note:** Arrows indicate traffic direction.



**Figure 45**  
Quad-Beam™ to Thrie-Beam  
Transition Panel



**Figure 46**  
Quad-Beam™ to W-Beam  
Transition Panel



**Note:** Arrows indicate traffic direction.

**Figure 47**  
Quad-Beam™ End Shoe Transition Panel



## 2) Mark System Location

Locate the centerline of the system by measuring the proper offset from the roadside obstacle. See the Manufacturer's Drawing Package supplied with the system. Place chalk line to mark the centerline of the system. Mark a construction line parallel to the center line and offset 165 mm [6.5"] to one side as shown in Figure 48. The edge of the Monorail will be placed on this line.

**Note:** The concrete foundation shall comply with the Manufacturer's Drawing Package supplied with the system.



**Warning:** Location of system with respect to the roadside object is critical and dependent on the type of Transition Panel used. See the Manufacturer's Drawing Package supplied with the system for details.



**Figure 48**  
(Top view of concrete foundation)

## 3) Anchor the Backup

### A) Concrete Backup Construction (Figure 49)

Locate Backup Face Plate using the Backup assembly drawing. Verify that any applicable Transition Panels fit properly before anchoring the Face Plate. Drill anchor boreholes in the Concrete Backup using the Face Plate as a template. Anchor the Face Plate to the Concrete Backup using a Trinity Highway approved adhesive supplied with the QuadGuard® II system (see Trinity Highway Approved Adhesive section, p. 15).

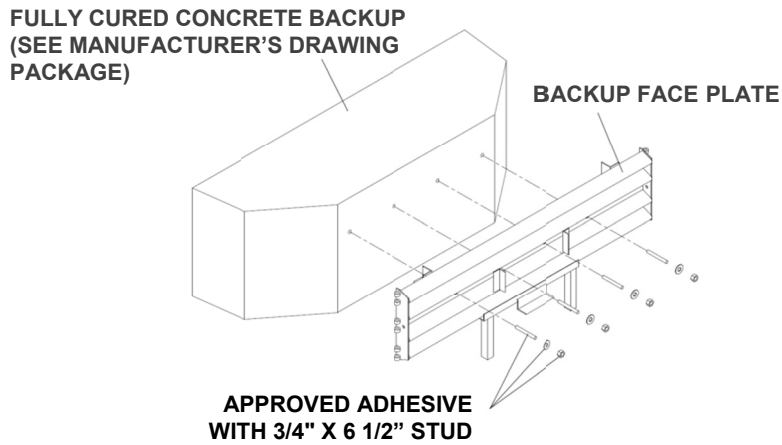
A Trinity Highway approved adhesive anchoring system is required to securely anchor crash cushions and other common highway devices. Trinity Highway approved adhesive features high pullout strength, vibration resistance, and durability. Each approved adhesive kit contains adhesive, studs, nuts and washers. Both vertical and horizontal assemblies require an approved adhesive anchoring system.



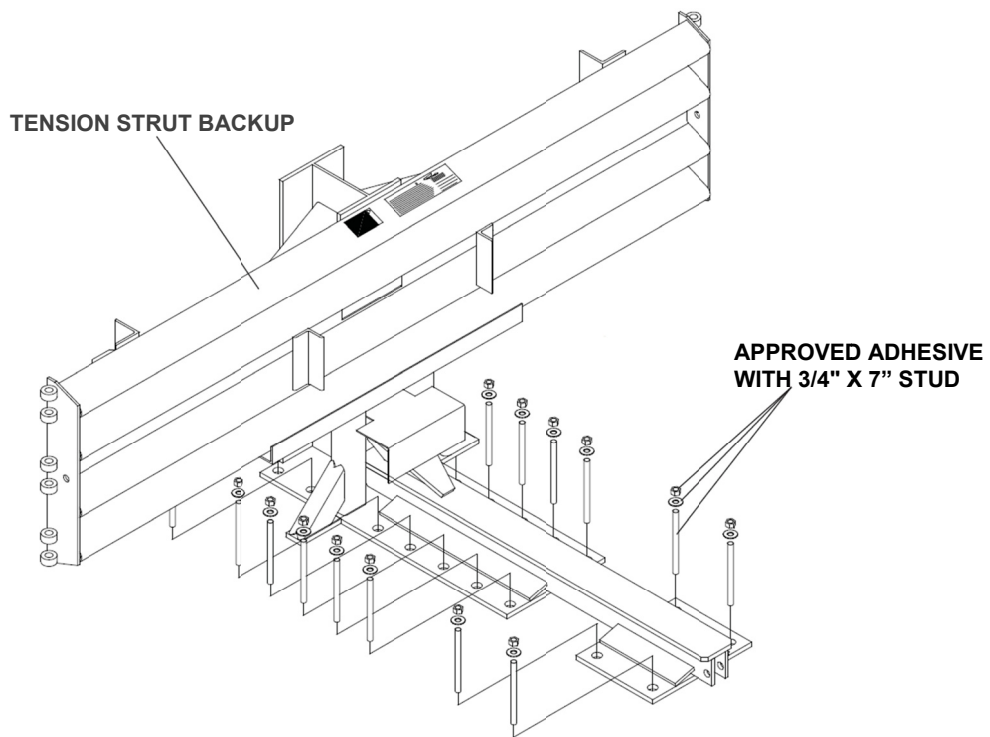
**Warning:** Every borehole and slot in Backup and Monorail must be anchored by a stud using an approved adhesive.

### B) Tension Strut Backup Assembly (Figure 50)

Locate the Tension Strut Backup and Monorail on foundation with side of Monorail on the construction line (see Figure 54, p. 50). Verify that any applicable Transition Panels fit properly before anchoring Backup. Drill anchor boreholes in foundation using the Backup as template. Anchor the Backup to the concrete foundation using the Trinity Highway approved adhesive supplied with the QuadGuard® II system (see Trinity Highway Approved Adhesive section, p. 15).



**Figure 49**  
**Anchoring Backup Face Plate to Concrete Backup**



**Figure 50**  
**Anchoring Tension Strut Backup to Foundation**

### C) Extra-Wide Tension Strut Backup Assembly (Figure 51)

Locate the Extra-Wide Tension Strut Backup **center** section and Monorail on foundation with side of Monorail on the construction line (see Figure 54, p. 50).

Locate the Extra-Wide Tension Strut Backup **left** section on the left side of the center section, aligning the three holes in the side plates.

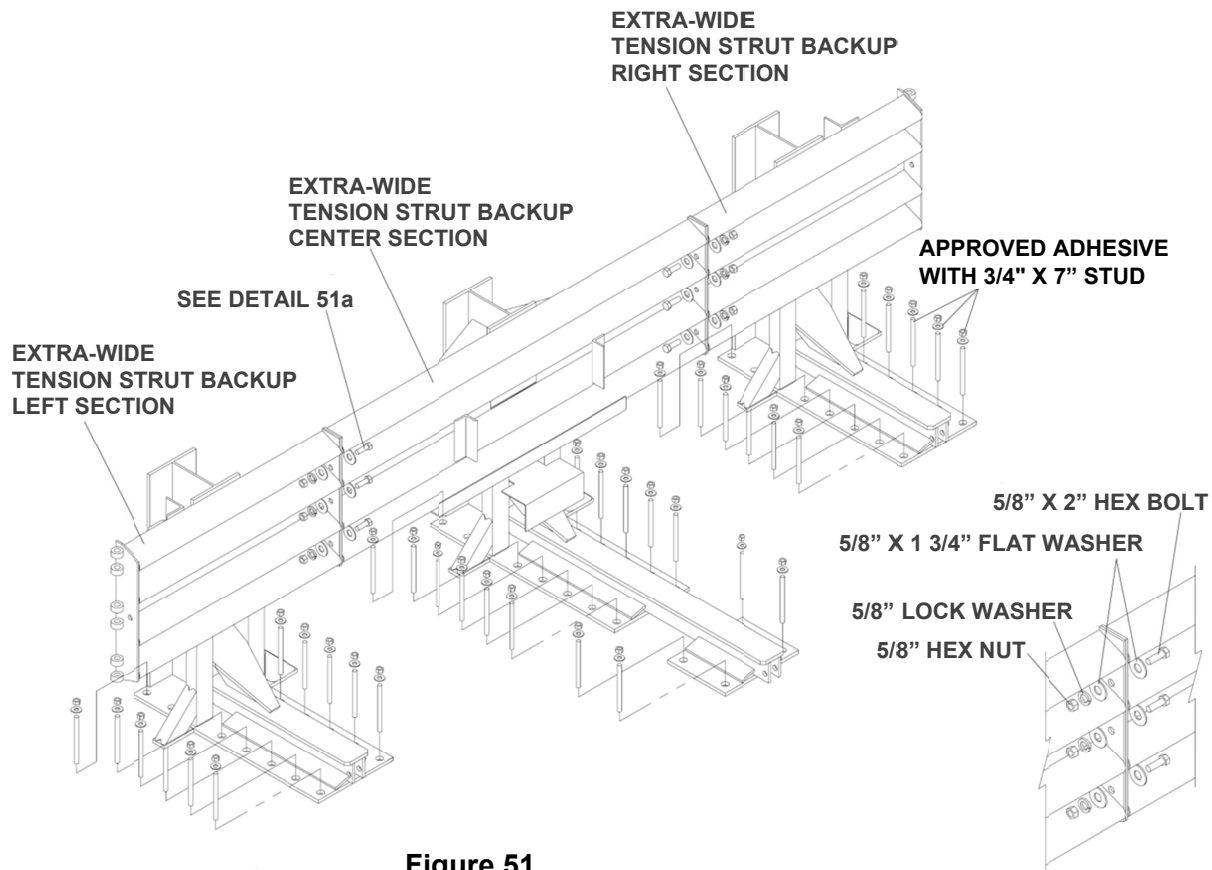
Locate the Extra-Wide Tension Strut Backup **right** section on the right side of the center section, aligning the three holes in the side plates.

Secure the Backup sections to each other using 5/8" x 2" hex bolt, 5/8" x 1 3/4" flat washer (2), 5/8" lock washer and 5/8" hex nut (6 places) as shown in Figure 51 and Detail 51a.

Verify that any applicable Transition Panels fit properly before anchoring Backup. Drill anchor boreholes in foundation using the Backup as template. Anchor the Backup to the foundation using Trinity Highway approved adhesive kits supplied with the QuadGuard® II system (see Trinity Highway Approved Adhesive section p. 15).



**Warning:** Every borehole and slot in Backup and Monorail must be anchored by a stud using a Trinity Highway approved adhesive.



**Figure 51**  
**Anchoring Extra-Wide Tension Strut Backup to Foundation See Manufacturer's Drawing Package**

**Detail 51a**

#### 4) Anchor the Monorail

##### A) Monorail Construction for Concrete Backup (Figure 52)

Locate Monorail on foundation with side of Monorail on the construction line and rear edge of Monorail 10" forward of front face of Concrete Backup. Orient the Monorail so that the Monorail tongues face Backup (see Figure 52).

Drill 140 mm [5 1/2"] deep anchor boreholes using the Monorail as a template. Do not drill through foundation.

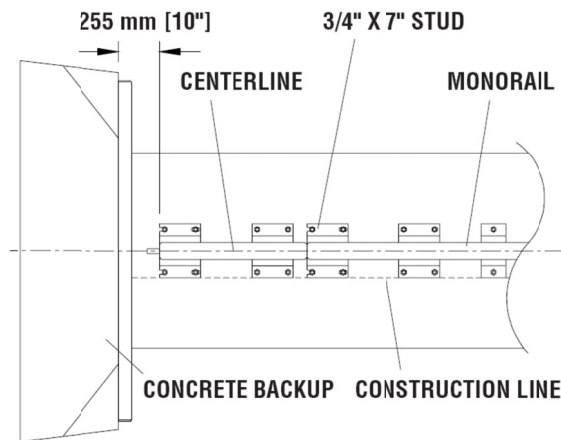


**Warning:** Improper alignment at the Monorail Splice Joints may prevent proper system collapse during impact.

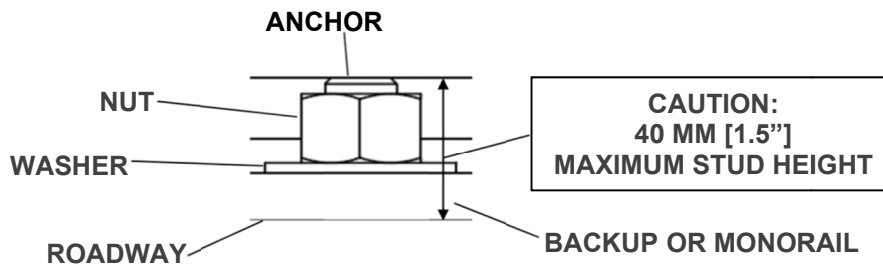
Anchor each Monorail section using an approved adhesive kit (see p. 15). See Figure 52 and the approved adhesive instructions included with the adhesive kit. It is important to attach each segment of Monorail in alignment from the back to the front of the system ( $\pm 6$  mm [1/4"]).



**Warning:** Every borehole and slot in Backup and Monorail must be anchored by a stud using an approved adhesive.



**Figure 52**  
**Monorail Location for Concrete Backup**



**Figure 53**  
**Proper Stud Height**

## Monorail Construction for Tension Strut Backup (Figure 54)

Locate Monorail on foundation with side of Monorail on the construction line and rear edge of Backup 4" forward of edge of foundation. Orient the Monorail so that the Monorail tongues face the Backup (see Figure 54).

Drill 140 mm [5 1/2"] deep anchor boreholes using the Monorail as a template. Do not drill through foundation.

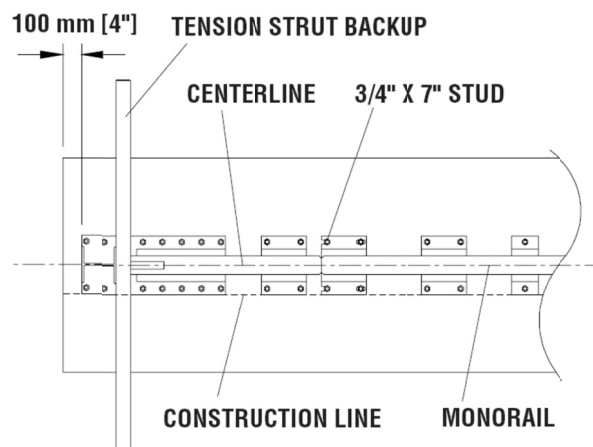


**Warning:** Every borehole and slot in Backup and Monorail must be anchored by a stud using an approved adhesive.

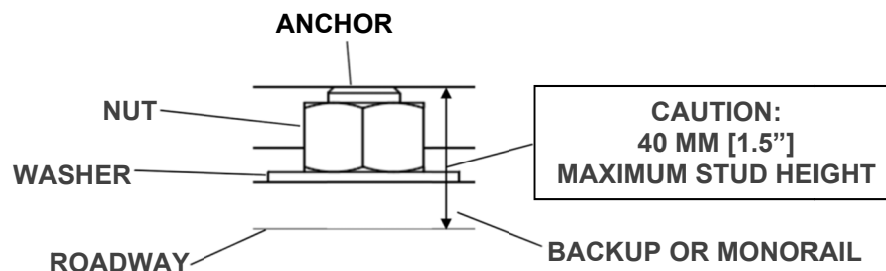
Anchor each Monorail section using the Trinity Highway approved adhesive kits provided. See Detail 20a and the approved adhesive instructions included with each kit. It is important to attach each segment of Monorail in alignment from the back to the front of the system ( $\pm 6$  mm [1/4"]).



**Warning:** Improper alignment at the Monorail splice joints will prevent proper system collapse during an impact.



**Figure 54**  
Backup and Monorail Location for Tension Strut Backup



**Figure 55**  
Proper Stud Height

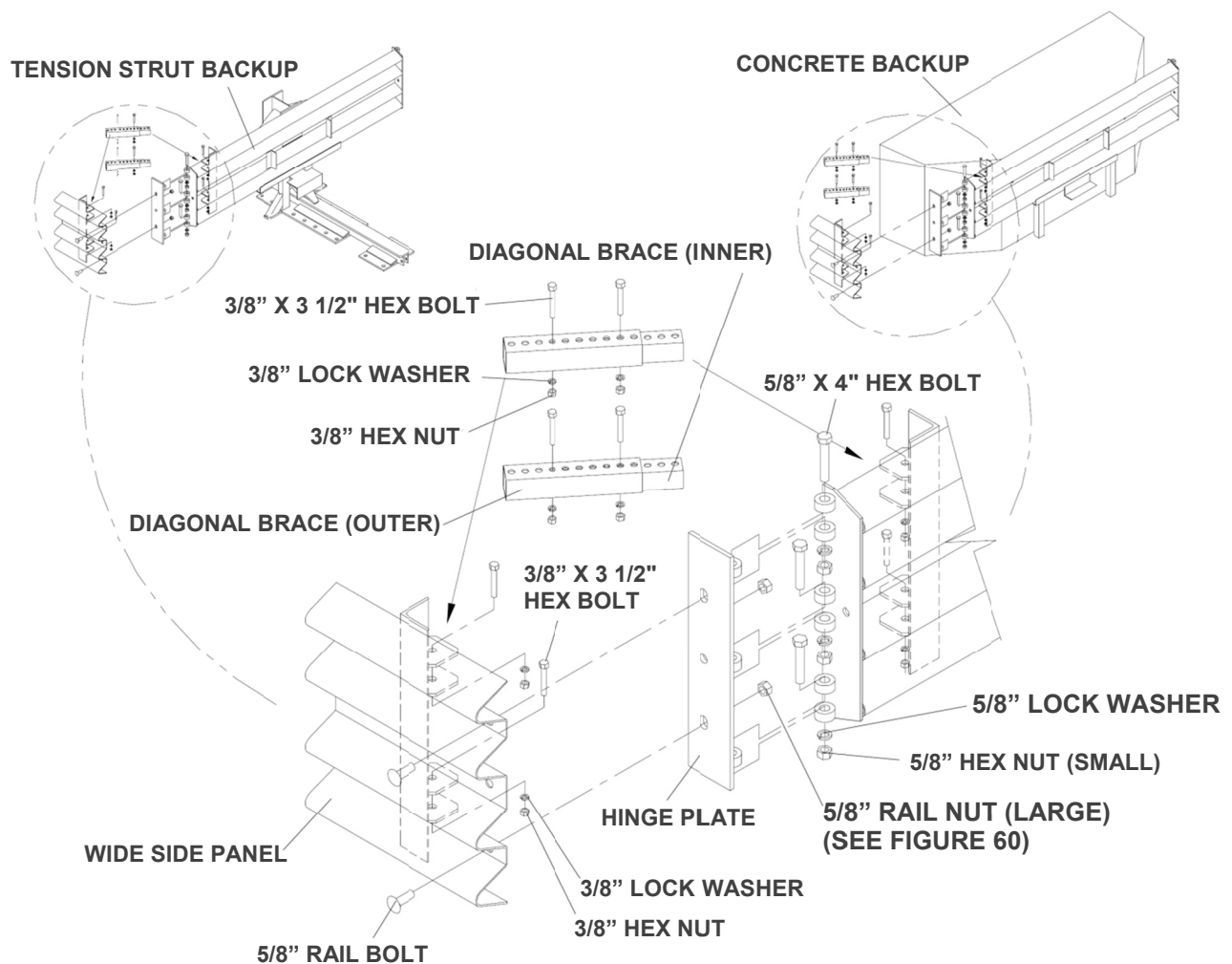
## 5) Attach Side Panels and/or Transition Panels to Backup Assembly

- a. Attach Hinge Plate to the Transition Panel or Side Panel using 5/8" rail bolt and 5/8" rail nut (two places – top and bottom holes only).
- b. Attach Transition Panel or Side Panel assembly to side of Backup using 5/8" hex bolt, 5/8" lock washer and 5/8" hex nut (three places each side of Backup) (see Figure 56).
- c. Attach diagonal brace to Fender Panel and Backup using 3/8" hex bolt, 3/8" lock washer and 3/8" hex nut (two (2) places per brace: four (4) places per side).
- d. Secure each diagonal brace with a 3/8" hex bolt; 3/8" lock washer, and 3/8" hex nut (two (2) places per brace) as shown in Figure 56.

**Note:** A Side Panel is not needed when a Transition Panel is used. Diagonal braces not used with some Transition Panels (see Manufacturer's Drawing Package).

### Assembly tip:

Use drift pin to align the center hole of the Panel with the center hole of the Backup before attaching the rail bolts.



**Figure 56**  
**Side Panel/Transition Panel Attachment**

## 6) Attach Monorail Guides

Attach Monorail guides to Diaphragm as follows:

Insert 3/4" x 2" G8 hex bolt through Monorail guide and Diaphragm, oriented as shown in Figure 57. Secure with 3/4" lock washer and 3/4" hex nut (typical two places per guide). See also Diaphragm assembly drawing. Shims are sandwiched between Monorail guides and Diaphragm.

Repeat process for each Diaphragm.

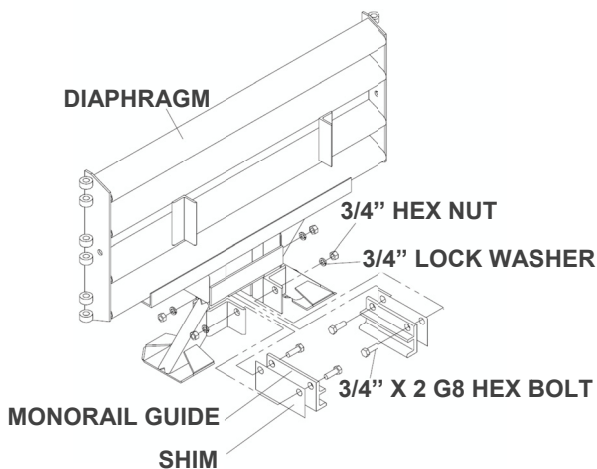
## 7) Attach Diaphragms

Orient the widest Diaphragm so that the front face of the Diaphragm shape faces toward the Nose of the system as shown in Figure 58. **The widest Diaphragm must be attached closest to the Backup with each subsequent Diaphragm being progressively narrower.**

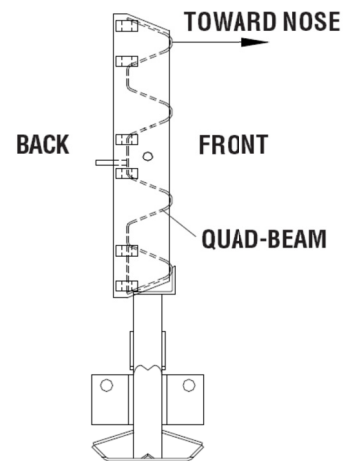


**Important:** Slide the widest Diaphragm onto the Monorail and all the way to the Backup to ensure system is able to collapse properly during impact. Once this has been verified, slide the Diaphragm forward to approximately 915 mm [36"] in front of the Backup.

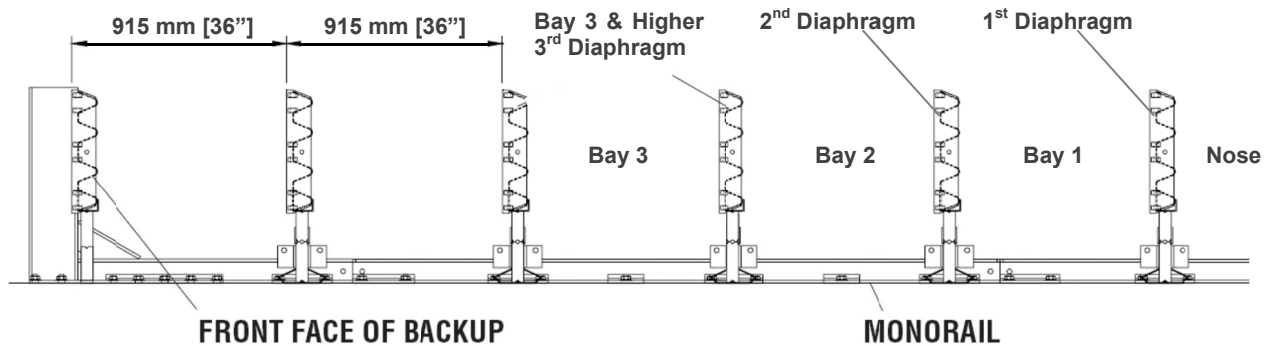
Orient and slide all other Diaphragms onto Monorail and position each approximately as shown in Figure 59.



**Figure 57**  
Monorail Guide Attachment



**Figure 58**  
Diaphragm Orientation



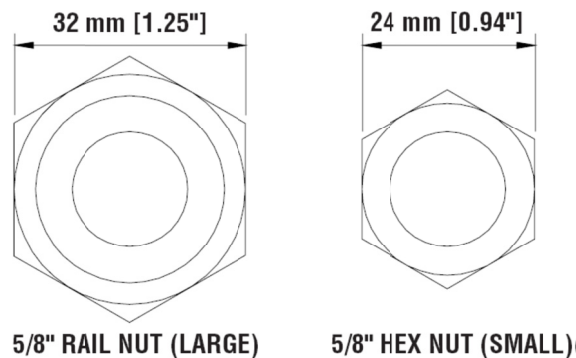
**Figure 59**  
Diaphragm spacing



## 8) Attach Hinge Plate onto Fender Panels



**Important:** Do not mix the 5/8" rail nuts (large) with the 5/8" hex nuts (small).

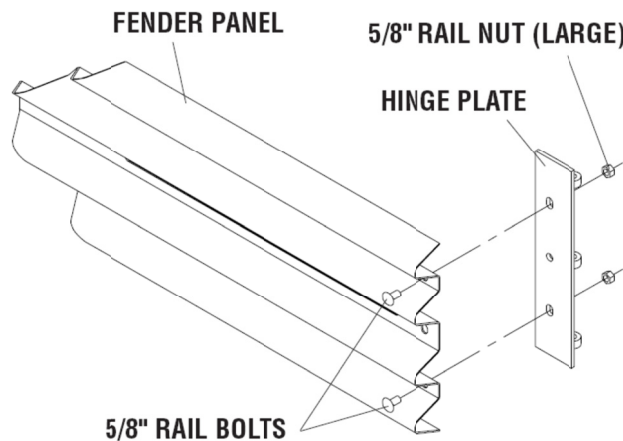


**Figure 60**  
**Rail Nuts are Oversize**



**Important:** For proper impact performance, wide systems must use Hinge Plates.

Attach Hinge Plate on each Fender Panel using two (2) 5/8" rail bolts and two (2) 5/8" rail nuts, using top and bottom holes only, leaving the center-hole open as shown in Figure 61.



**Figure 61**  
**Hinge Plate Assembly**

## 9) Attach Fender Panels

Starting at the Backup, attach left and right Fender Panels as shown in Figure 62.

### Step 1

Place the Fender Panel so that the center of the slot of the rearward Diaphragm is lined up with the approximate center of the slot in the Fender Panel.

Attach Mushroom Washer Assembly as shown in Figure 62 and Detail 62a, but do not torque at this time (this helps to balance the Fender Panel).

**Step 2**

Slide the Fender Panel forward until the holes in the Fender Panel line up with the holes in the forward Diaphragm.

**Step 3**

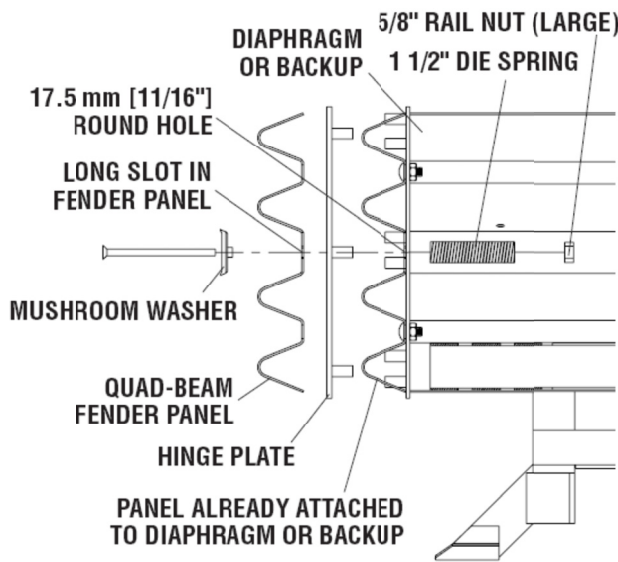
Use a drift pin to align the center hole of the Fender Panel with the center hole of the Diaphragm.

**Step 4**

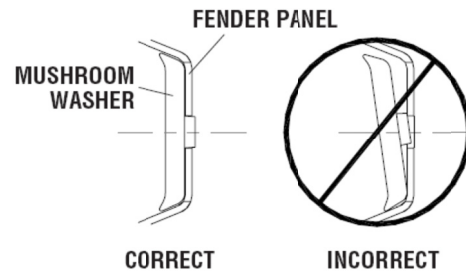
Attach the front of the Fender Panels to the next Diaphragm using two (2) rail bolts and large hex nuts per side. Use only the top and bottom holes; leave the center hole open until the next Fender Panel is attached.

**Step 5**

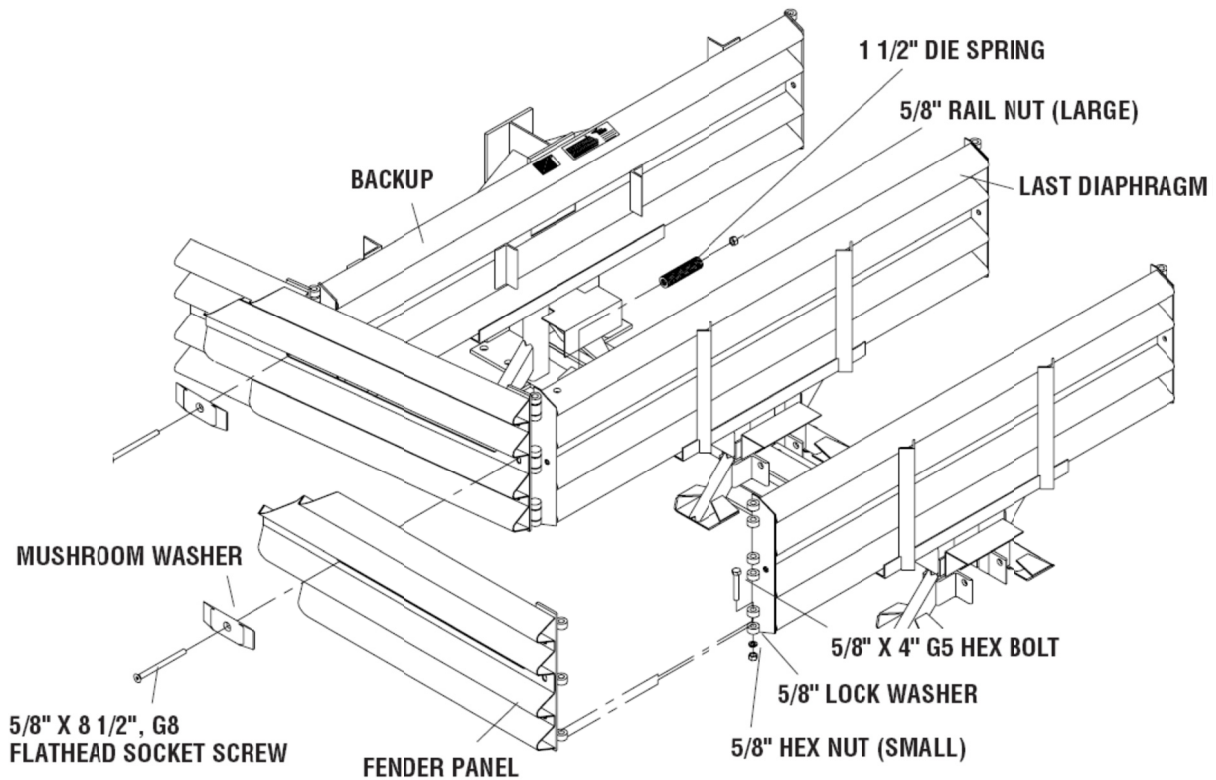
Be sure Mushroom Washer lays flat against the Fender Panel as shown in Detail 59a. Standoff on Mushroom Washer must be seated completely through slot.



**Figure 62**  
**Mushroom Washer Attachment**



**Detail 62a**  
**Mushroom Washer Orientation**



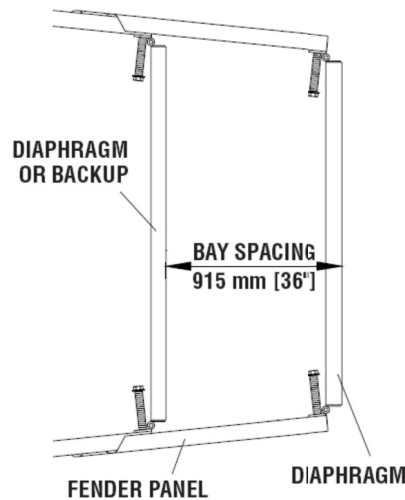
**Figure 63**  
**Fender Panel Assembly**

**Step 6**

Check Diaphragm spacing to ensure 915 mm [36"] between rear faces of consecutive Diaphragms as shown in Figure 64 and Fender Panel Assembly drawing.

**Step 7**

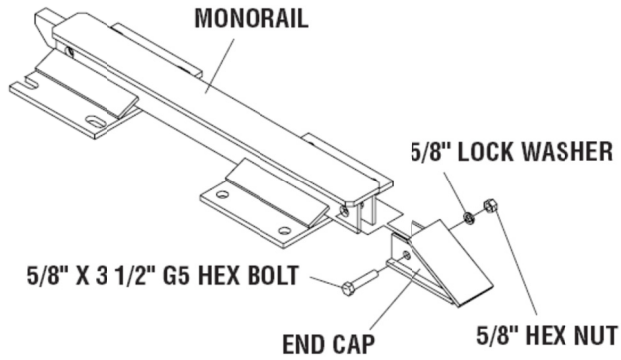
Once the proper spacing has been achieved, torque the Mushroom Washer Assembly (small hex nut) until it reaches the end of the threads. Assemble the remaining Diaphragms and Fender Panels following the same procedures.



**Figure 64**  
**Proper Diaphragm Spacing**

### 10) Attach End Cap

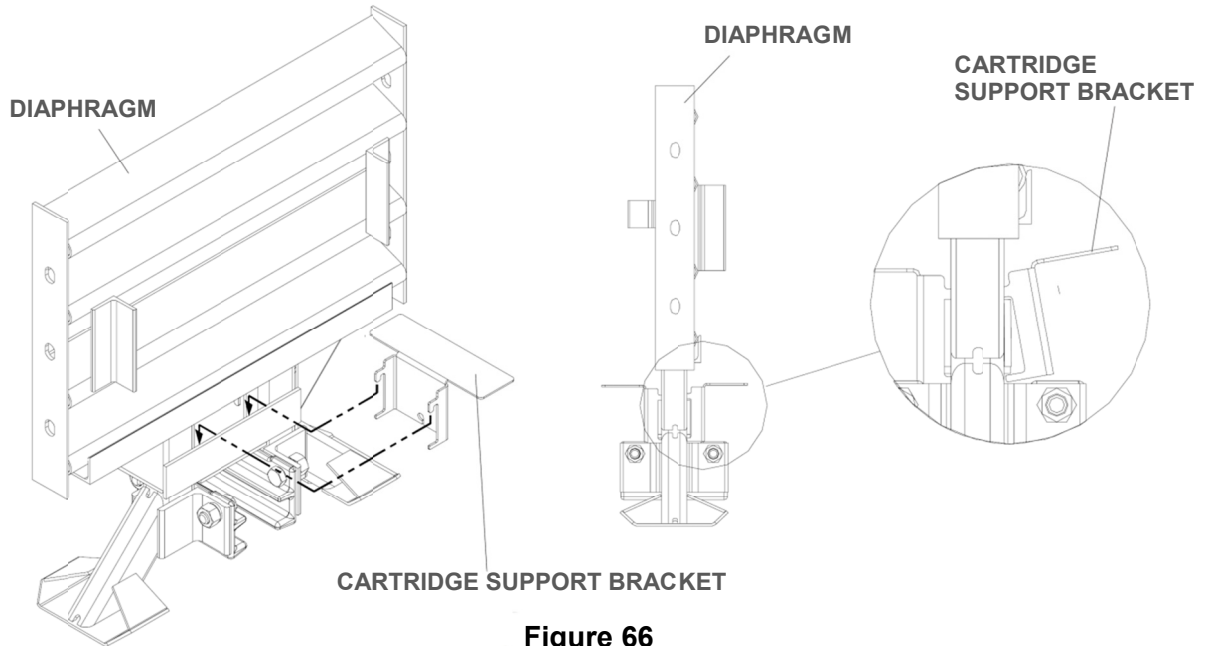
Using 5/8" x 3 1/2" G5 hex bolt, 5/8" hex nut and 5/8" lock washer, attach the End Cap to the front of the first Monorail segment as shown in Figure 65 and the Monorail Assembly drawing.



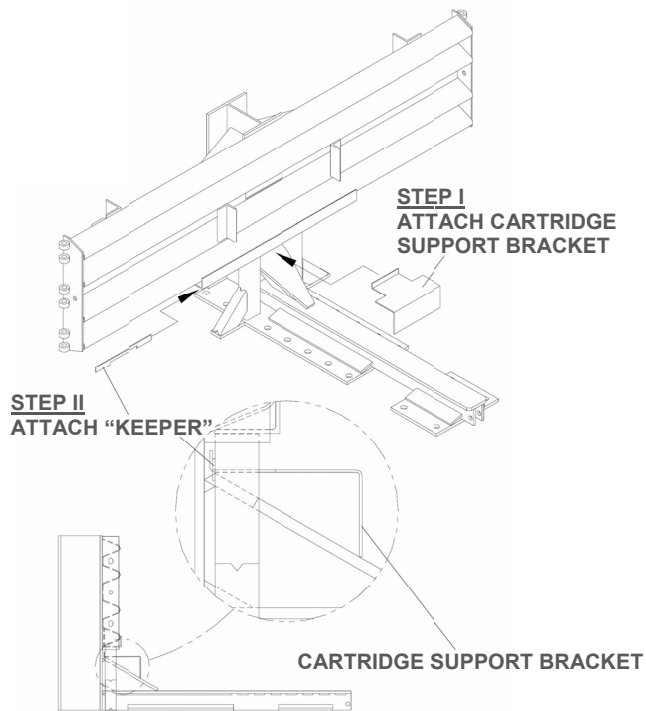
**Figure 65**  
**Monorail End Cap Assembly**

## 11) Attach Cartridge Support Brackets

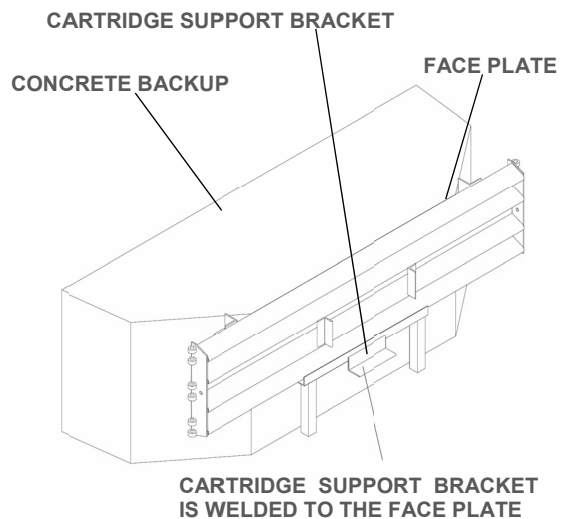
Attach Cartridge Support Bracket to all Diaphragms and Backup as shown in Figures 66 - 69, the Backup Assembly drawing, and the Diaphragm Assembly drawing.



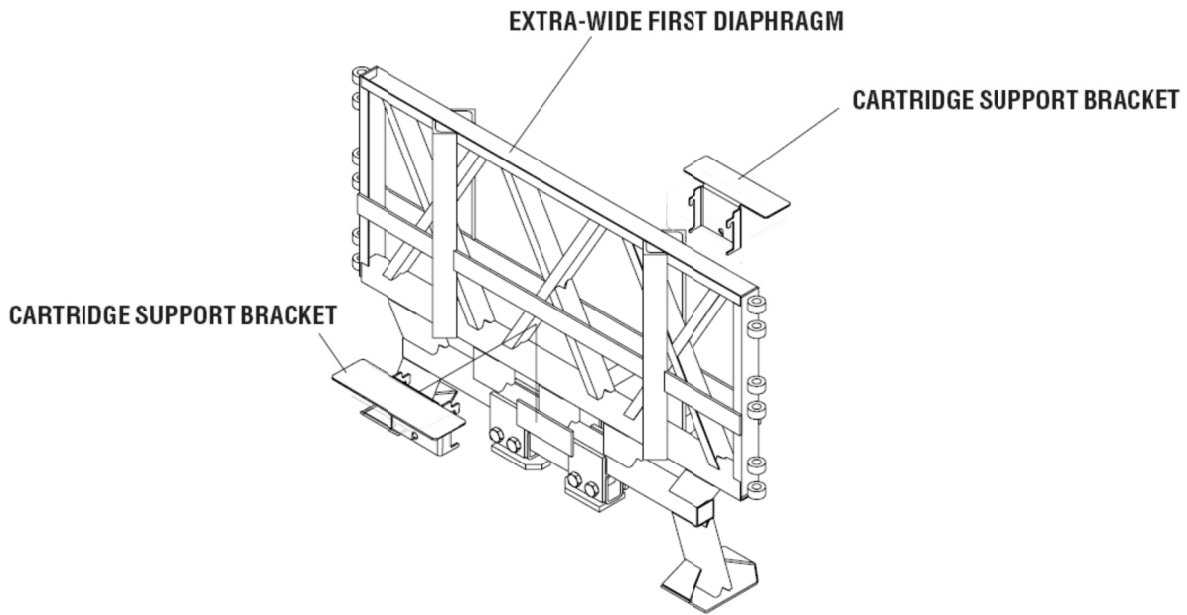
**Figure 66**  
**Diaphragm with**  
**Cartridge Support Bracket**



**Figure 67**  
**Cartridge Support Bracket**  
**(Tension Strut Backup)**



**Figure 68**  
**Cartridge Support Bracket**  
**(Concrete Backup)**



**Figure 69**  
**Extra-Wide First Diaphragm with Cartridge Support Bracket**  
 (See Drawing Package)

**12) Attach Nose Assembly**

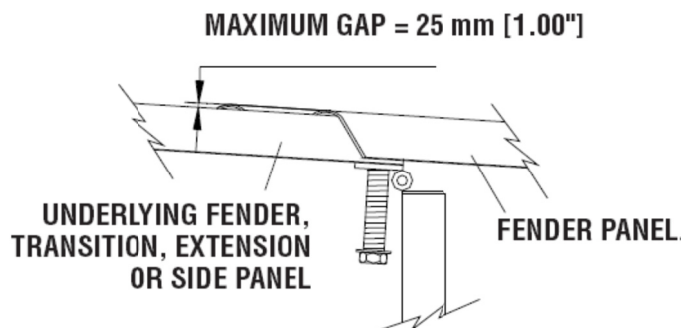
See pages 35 and 36 for Nose Assembly instructions.

**13) Checking the System Assembly**

Recheck to ensure that all fasteners are properly tightened throughout the system (anchor bolts, etc.). Review torque requirements below and inspect all Fender Panels. If they do not fit tightly against the underlying Fender Panels, system realignment may be necessary (see Figure 70).



<b>Warning:</b>
<b>Bolt Torque Requirements</b>
Anchor Studs – see Table A, p. 15 May slightly protrude above nuts
<b>Critical Clearances</b>
Anchor Studs above nuts – see Figure 55, p. 50 Fender Panel Gap Wide – 25 mm [1.00"] see below



**Figure 70**  
**Fender Panel Gap for Wide Systems** Revision C December 2016

## 14) Cartridge Attachment

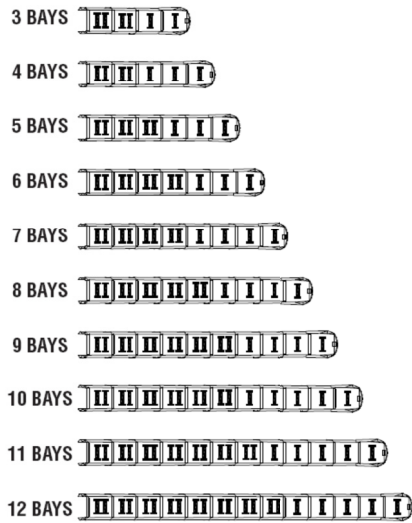
Ensure the Adjustable Cartridge Support in the Nose is attached correctly. See “Attach Nose Assembly” in Step 11 on page 35. The top surface of the Nose Cartridge should be horizontal.

To complete the assembly of a QuadGuard® II system, place the appropriate Cartridge in each Bay and Nose section of the system. Type I Cartridges are placed toward the front (Nose) of the system; Type II Cartridges are placed toward the rear (Backup) of the system (see Figures 71 and 72).

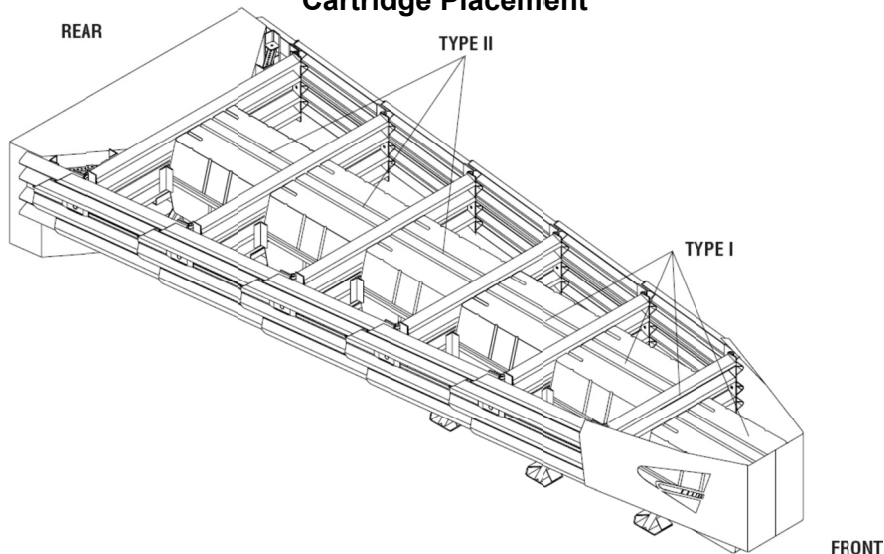


**Warning:** Placing the wrong Cartridge in the Nose or any Bay will result in system performance that has not been crash tested pursuant to the NCHRP Report 350 criteria.

I - TYPE I CARTRIDGE  
II - TYPE II CARTRIDGE



**Figure 71  
Cartridge Placement**



**Figure 72  
Typical Cartridge Layout (5 Bay System Shown)**



# Maintenance and Repair

## Inspection Frequency

Inspections are recommended as needed based upon volume of traffic and impact history. Visual Drive-By Inspections are recommended at least once a month. Walk-Up Inspections are recommended at least twice a year for QuadGuard® II systems on asphalt (see p. 15).

## Visual Drive-By Inspection

- 1) Check to see if there is evidence of an impact. If so, a walk-up inspection will be necessary.
- 2) Check to see if the Cartridges appear to be off the Support Brackets. Any damaged Cartridges will need to be replaced.



**Warning:** See Cartridge placement instructions on pages 38 and 57.

- 3) Be sure the Steel Nose is in place.
- 4) Note the location and condition of the QuadGuard® II system and the date of visual drive-by inspection.

## Walk-Up Inspection

- 1) Clear and dispose of any debris on the site.
- 2) Ensure bolts are tight and rust free.
- 3) Ensure all anchor bolts are securely anchored (see Table A, p. 15).
- 4) Ensure Diaphragm Legs are straight.
- 5) Ensure all Mushroom Washer Assemblies are properly aligned and positioned.
- 6) Ensure Fender Panels and Transition Panels are nested tightly against the system.



<b>Warning:</b>	
Fender Panel	Maximum gap allowed:
<b>Narrow Systems</b>	<b>20 mm [0.78"]</b>
<b>Wide Systems</b>	<b>25 mm [1.00"]</b>

See Figures 76 and 77 on page 63.

- 7) Ensure Cartridges have not been damaged and are properly positioned on their Support Brackets. Replace crushed or sagging Cartridges. To ensure 100% of the intended speed characteristics, partially crushed Cartridges (due to slow speed impacts) shall be replaced.
- 8) Make all necessary repairs as described above. See Post-Impact Instructions on page 62 for more information.
- 9) Note the location and condition of the QuadGuard® II system and any work done in the Impact Attenuator Inspection Logbook under the date of this inspection. If further repair is necessary, note repair request date in logbook. See Post-Impact Instructions on page 62, and the Assembly section on page 22 of this manual for more information.
- 10) In deciding if a product should be replaced, or is potentially reusable, a trained engineer, experienced in highway products, directed by the DOT, or other appropriate local highway authority, must be consulted.

## Post-Impact Instructions



**Danger:** If either (**wide or narrow**) system is anchored to asphalt and less than 10% of the total anchors are damaged, then each damaged anchor must be replaced. If more than 10% of the anchors are damaged, then the system must receive a fresh, undisturbed asphalt foundation and be redeployed using 460 mm [18"] threaded rods.

### **Narrow Systems**

- 1) Deploy the appropriate traffic-control devices for protection.
- 2) Check to see that all anchor bolts have remained firmly anchored in the roadway surface. Replace any that are loose, broken, or pulled out.

The proper performance of the system during an angle impact depends on the Monorail anchors being properly anchored.

- 3) Clear and dispose of any debris on the site.
- 4) Check the system to be certain that the Mushroom Washer Assemblies holding the Fender Panels together are still intact and that the system has not been deformed in a way that would prevent pulling it back to its original position.
- 5) Be sure that the Diaphragm Support Legs are all properly attached to the Monorail.

### **Wide Systems**

- 1) Deploy the appropriate traffic-control devices for protection.
- 2) Check to see that all anchor bolts have remained firmly anchored in the roadway surface. Replace any that are loose, broken, or pulled out.

The proper performance of the system during an angle impact depends on the Monorail Anchors being properly anchored.



**Caution:** QuadGuard® II wide systems should never be anchored to asphalt.

- 3) Clear and dispose of any debris on the site.
- 4) Check the system to be certain that the Mushroom Washer Assemblies holding the Fender Panels together are still intact and that the system has not been deformed in a way that would prevent pulling it back to its original position.
- 5) Be sure that the Diaphragm Support Legs are all properly attached to the Monorail.

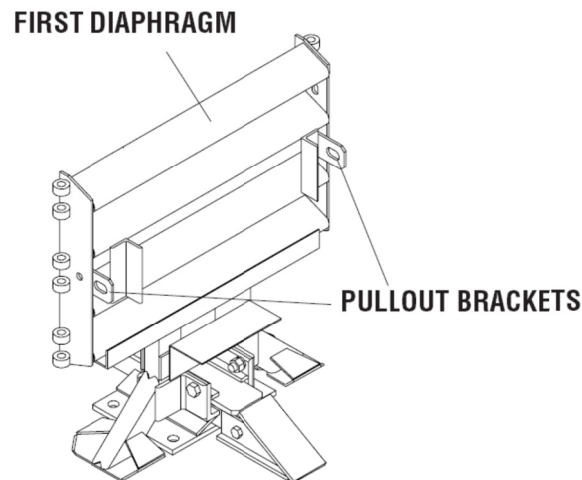


**Caution:** Use safety goggles and gloves when refurbishing the Mushroom Spring Assembly. Do not place fingers underneath an assembled Mushroom Washer. Parts may suddenly shift and fingers may be pinched. If the spring is still under compression as the nut is nearing the end of the bolt, to prevent injury, make sure that the spring is restrained with a clamp so it does not suddenly release when nut is removed from the Mushroom Washer Bolt.

- 6) Attach chain to Pullout Brackets on first Diaphragm (see Figure 73). Attach both ends of chain to a heavy vehicle (such as a 1 ton pickup).



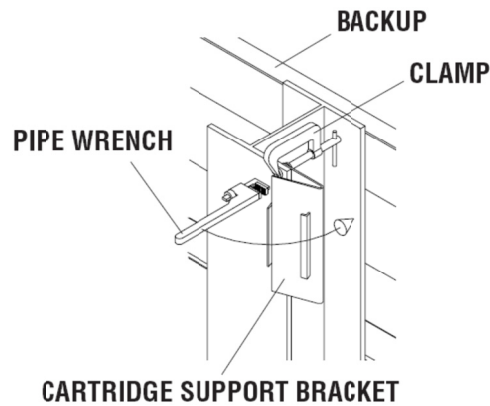
**Warning:** Stand clear in case chain breaks or becomes disconnected.



**Figure 73  
Pullout**

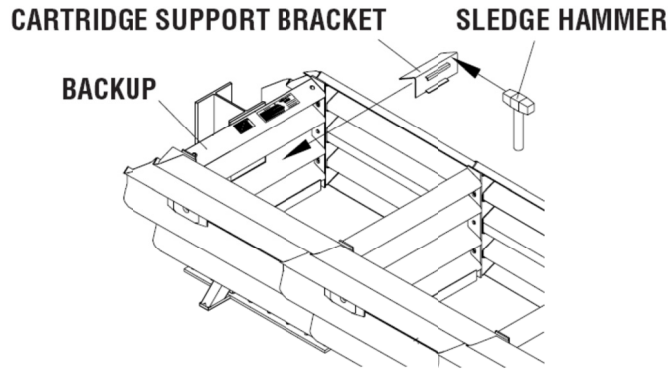
Slowly pull the QuadGuard® II system forward until the system reaches its original length. Have someone watch the system during repositioning to be certain previously undetected damage does not cause the Diaphragms to bind or pull out improperly.

- 7) Remove all crushed Cartridges from within the system.
- 8) Check to see that the Diaphragms are in usable condition. Diaphragms which are bowed or have bent legs must be replaced.
- 9) Check that the Fender Panels are properly attached with the Mushroom Washer Assemblies. Damaged Fender Panels and Transition Panels must be replaced. Often, Cartridge Support Brackets with minor damage can be straightened and reused by doing the following:
  - a. Remove damaged Cartridge Support Bracket from Diaphragm.
  - b. Clamp Cartridge Support Bracket to Backup and begin bending using pipe wrench as shown in Figure 74.



**Figure 74  
Straighten Cartridge Support Bracket**

- c. Then, using a sledge hammer and Quad-Beam™ Panel on Backup as an anvil, straighten Cartridge Support Bracket back into 90° shape (see Figure 75).

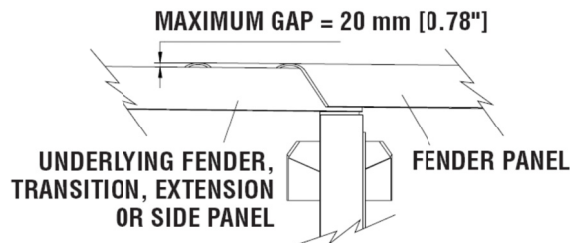


**Figure 75**  
**Form Cartridge Support Bracket**

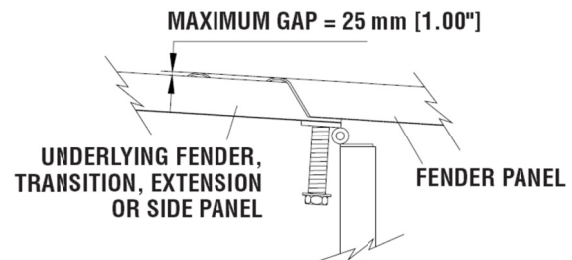


<b>Warning:</b>	
Fender Panel	Maximum gap allowed:
<b>Narrow Systems</b>	<b>20 mm [0.78"]</b>
<b>Wide Systems</b>	<b>25 mm [1.00"]</b>

- 10) Check the **gaps between Fender Panels**. The maximum gap allowed for these overlapping parts (including Fender Panels overlapping Panels behind the system) is 20 mm [.78"] for **narrow systems** and 25 mm [1.00"] for **wide systems**. Be sure the Mushroom Washer Assemblies are torqued to the end of the threads. If the gaps between the Fender Panels are still too large, it may be necessary to replace bent parts.



**Figure 76**  
**Fender Panel Gap for Narrow Systems**



**Figure 77**  
**Fender Panel Gap for Wide Systems**

- 11) Replace all crushed Cartridges. See Cartridge Placement on pages 41 and 59.
- 12) Remove damaged Nose Assembly and attach the new Nose to the first Diaphragm. See pages 38 and 39 for system Nose Assembly.



**Important:** Trinity Highway makes no recommendation whether use or reuse of any part of the system is appropriate or acceptable following an impact. It is the sole responsibility of the project engineer and/or the local highway authority and its engineers to make that determination. It is critical that you inspect this product after assembly is complete to make certain that the instructions provided in this manual have been strictly followed.

**Table C**



<b>Warning:</b>
<b>Bolt Torque Requirements</b>
Anchor Studs – see Table A, p. 15 May slightly protrude above nuts – see Figure 55, p. 50
<b>Critical Clearances</b>
Anchor Studs above nuts – see Figure 20, p. 29 <b>Fender Panel Gap Narrow – 20 mm [0.78”]</b> <b>Fender Panel Gap Wide – 25 mm [1.00”]</b>

13) Check the torque of all bolts on the system (see Table A, p. 15).

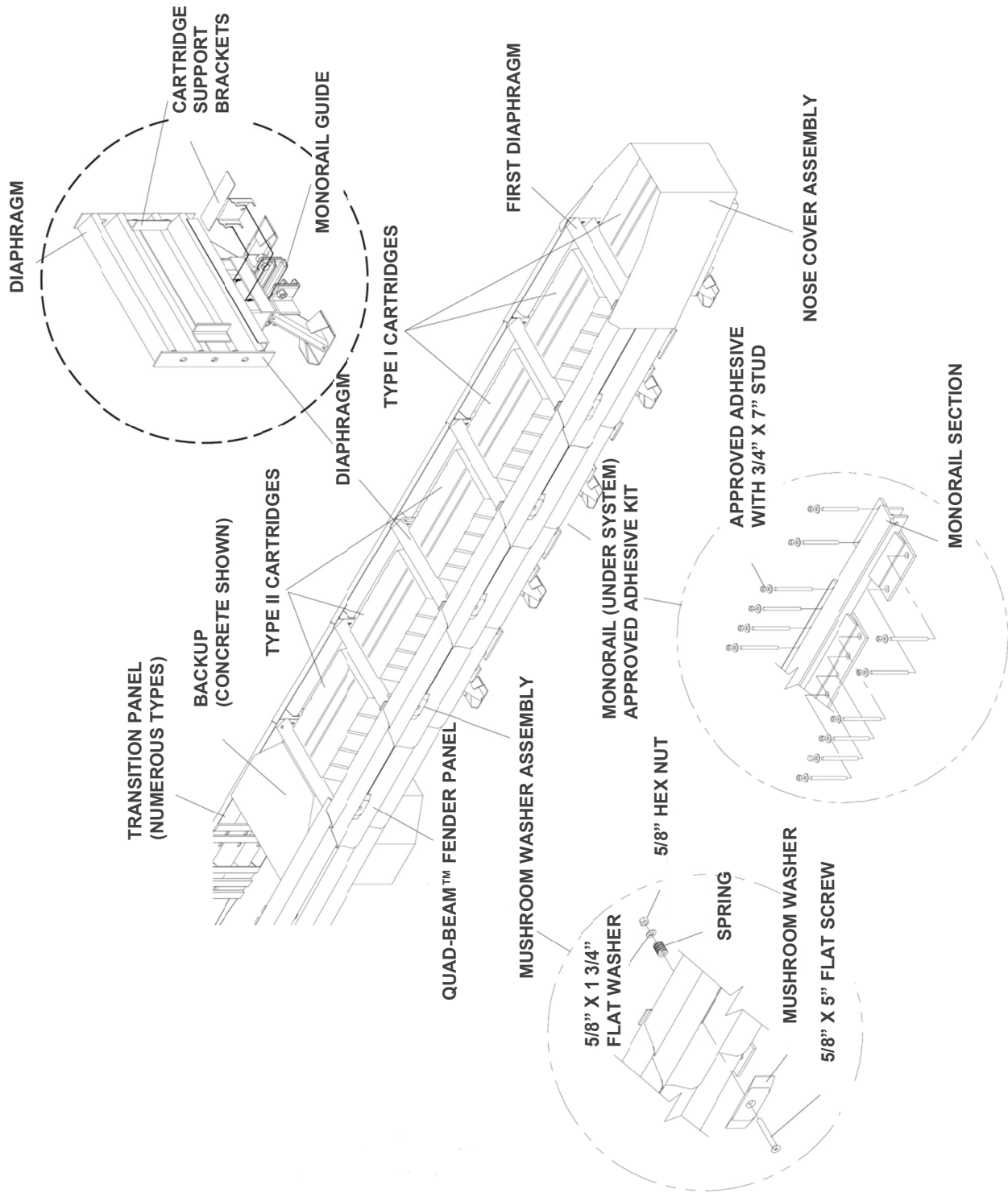
14) Check to be certain that the site is free from any debris. The QuadGuard® II system is once again ready for use.

## Parts Ordering Procedure

Make a list of all damaged parts using part descriptions shown on pages 65 and 66 of the system images. Answer the following questions in the spaces provided. This information is necessary to receive the proper parts.

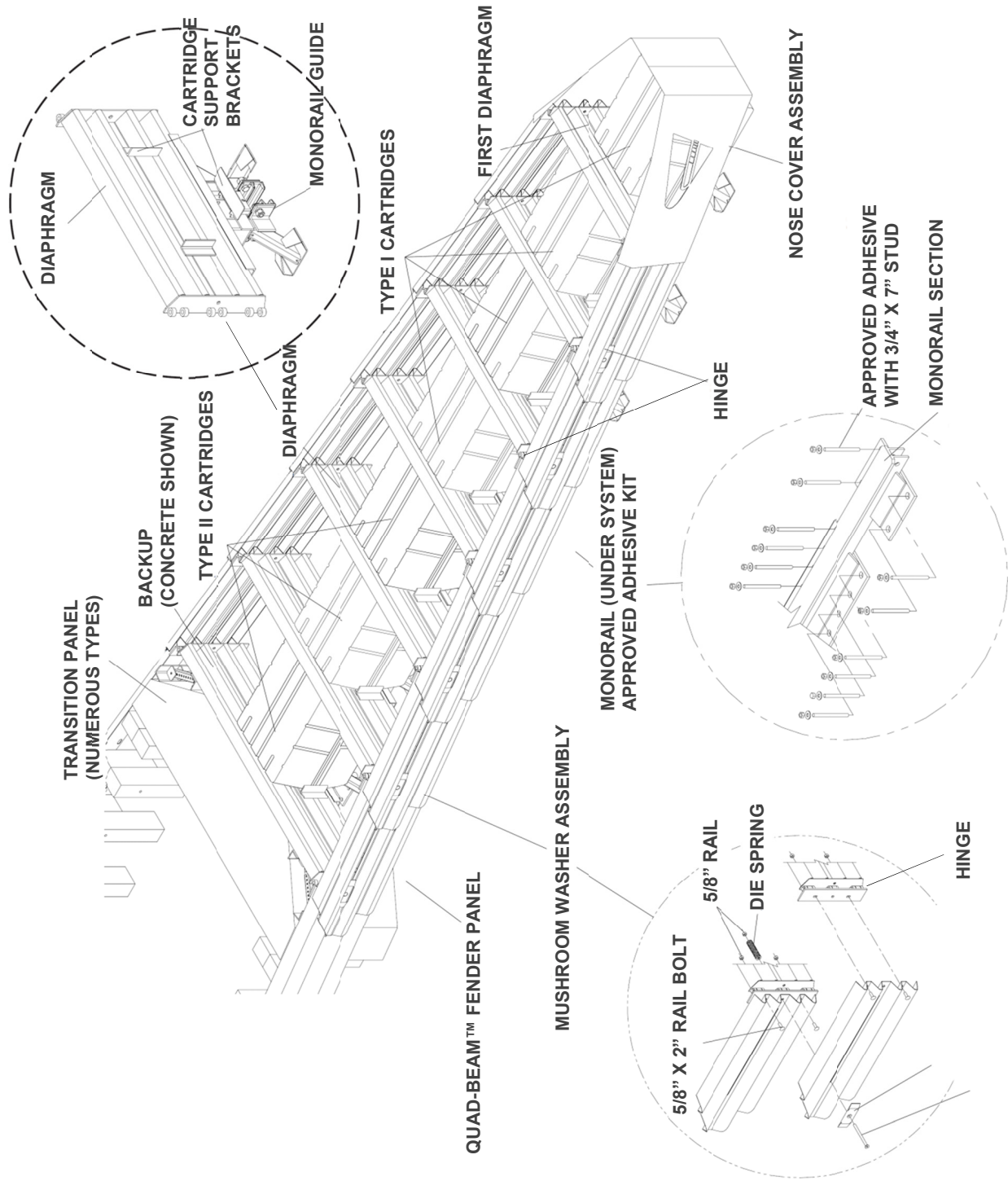
**Table D**  
**QuadGuard® II System Ordering Information Chart**

Description:	Choices	Fill in this section
What is the width of the system? See “Measuring the Width” on page 19.	610 mm [24”] 760 mm [30”] 915 mm [36”] 1219 mm [48”] 1755 mm [69”] 2285 mm [90”] 3200 mm [126”]	
<b>What is the Number / Type of Bays?</b> See Bay information on pages 21 and 59.	Narrow Systems: 1 through 9 Wide Systems: 3 through 9	
<b>What Type of Backup Does the System Have?</b> See Figures 8 or 9 on page 25.	Concrete Tension Strut	
<b>What Type of Transition Panel?</b> (See “Side Panel and Transition Panel Types” on page 26.) Be sure to note right side, left side, both sides (see “How to Determine Left/Right” on page 21) or no Transitions.	<ul style="list-style-type: none"> <li>• Quad to W</li> <li>• Quad to Thrie</li> <li>• Quad to Safety Shape Barrier</li> <li>• Quad to End Shoe</li> <li>• 4” Offset Panel</li> </ul>	



**Figure 78**  
**QuadGuard® II for Narrow**  
**Roadside Obstacles**





**Figure 79**  
**QuadGuard® II for Wide**  
**Roadside Obstacles**



# TRINITY

## HIGHWAY

*Ahead of the Curve™*

For more complete information on Trinity Highway products and services, visit us on the web at [www.trinityhighway.com](http://www.trinityhighway.com). Materials and specifications are subject to change without notice. Please contact Trinity Highway to confirm that you are referring to the most current instructions.

[www.trinityhighway.com](http://www.trinityhighway.com)

888.323.6374 (USA)

+1 214.589.8140 (International)