

QuadGuard® Elite

Assembly Manual



TRINITY
HIGHWAY

Ahead of the Curve™

QuadGuard[®] Elite

Assembly Manual



2525 Stemmons Freeway
Dallas, Texas 75207



Important: These instructions are to be used only in conjunction with the assembly, maintenance, and repair of the QuadGuard[®] Elite system. These instructions are for standard assemblies specified by the appropriate highway authority only. In the event the specified system assembly, maintenance, or repair would require a deviation from standard assembly parameters, contact the appropriate highway authority engineer. This system has been accepted by the Federal Highway Administration for use on the national highway system under strict criteria utilized by that agency. Trinity Highway representatives are available for consultation if required.

This Manual must be available to the worker overseeing and/or assembling the product at all times. For additional copies, contact Trinity Highway at (888) 323-6374 or download copies from the website below.

The instructions contained in this Manual supersede all previous information and Manuals. All information, illustrations, and specifications in this Manual are based on the latest QuadGuard[®] Elite system information available to Trinity Highway at the time of printing. We reserve the right to make changes at any time. Please contact Trinity Highway to confirm that you are referring to the most current instructions.

Table of Contents

Customer Service Contacts	3
Important Introductory Notes	3
Safety Rules for Assembly	4
Safety Symbols	5
Warnings and Cautions.....	5
Limitations and Warnings.....	6
System Overview	7
Recommended Tools	8
QuadGuard® Elite for Narrow Roadside Obstacles.....	12
Assembly Narrow	13
QuadGuard® Elite for Wide Roadside Obstacles	33
Assembly Wide	34
MP-3® Polyester Anchoring System.....	52
Horizontal Assemblies	54
MP-3® Assembly Cautions	55
Maintenance	56
Visual Drive-By Inspection	56
Walk-Up Inspection	56
Post-Impact Instructions	58
Restoring Collapsed System.....	61
Parts Ordering Procedure	62
Maintenance Flow Chart.....	65

Customer Service Contacts

Trinity Highway is committed to the highest level of customer service. Feedback regarding the QuadGuard® Elite system, its assembly procedures, supporting documentation, and performance is always welcome. Additional information can be obtained from the contact information below:

Energy Absorption Systems, Inc. dba Trinity Highway

Telephone:	(888) 323-6374 (USA) (214) 589-8140 (International)
E-mail:	product.info@trin.net
Website	www.trinityhighway.com

Important Introductory Notes

Proper assembly of the QuadGuard® Elite system is critical to achieve performance that has been evaluated and accepted by the Federal Highway Administration (FHWA) per NCHRP Report 350. These instructions should be read in their entirety and understood before assembling QuadGuard® Elite system. These instructions are to be used only in conjunction with the assembly of QuadGuard® Elite system and are for standard assemblies only as specified by the applicable highway authority. If you need additional information, or have questions about the QuadGuard® Elite system, please contact the highway authority that has planned and specified this assembly and, if needed, contact Trinity Highway's Customer Service Department. This product must be assembled in the location specified by the appropriate highway authority. If there are deviations, alterations, or departures from the assembly protocol specified in this Manual, the device may not perform as it was tested and accepted.

This system, like other Trinity Highway systems, has been crash tested pursuant to NCHRP Report 350 mandated criteria.



Important: DO NOT use any component part that has not been specifically crash tested and/or approved for this system during the assembly or repair of this system.

This product has been specified for use by the appropriate highway authority and has been provided to that user who has unique knowledge of how this system is to be assembled. No person should be permitted to assist in the assembly, maintenance, or repair of this system that does not possess the unique knowledge described above. These instructions are intended for an individual qualified to both read and accurately interpret them as written. These instructions are intended only for an individual experienced and skilled in the assembly of highway products that are specified and selected by the highway authority.

A manufacturer's drawing package will be supplied by Trinity Highway upon request. Each system will be supplied with a specific drawing package unique to that system. Such drawings take precedence over information in this Manual and shall be studied thoroughly by a qualified individual who is skilled in interpreting them before the start of any product assembly.



Important: Read safety instructions thoroughly and follow the assembly directions and suggested safe practices before assembling, maintaining, or repairing the QuadGuard® Elite system. Failure to follow this warning can result in serious injury or death to workers and/or bystanders. It further compromises the acceptance of this system by the FHWA. Please keep up-to-date instructions for later use and reference by anyone involved in the assembly of the product.



Warning: Ensure that all of the QuadGuard® Elite system Danger, Warning, Caution, and Important statements within the QuadGuard® Elite Manual are completely followed. Failure to follow this warning could result in serious injury or death in the event of a collision.

Safety Rules for Assembly

*** Important Safety Instructions ***

This Manual must be kept in a location where it is readily available to persons who are skilled and experienced in the assembly, maintenance, or repair of the QuadGuard® Elite system. Additional copies of this Manual are immediately available from Trinity Highway by calling (888) 323-6374 or by email at product.info@trin.net. Please contact Trinity Highway if you have any questions concerning the information in this Manual or about the QuadGuard® Elite system. This Manual may also be downloaded directly from the website listed below.

Always use appropriate safety precautions when operating power equipment, mixing chemicals, and when moving heavy equipment or the QuadGuard® Elite system components. Work gloves, safety goggles, safety-toe shoes, and back protection should be used.

Safety measures incorporating traffic control devices specified by the highway authority must be used to provide safety for personnel while at the assembly, maintenance, or repair site.

Safety Symbols

This section describes the safety symbols that appear in this QuadGuard® Elite Manual. Read the Manual for complete safety and assembly information.

Symbol

Meaning



Safety Alert Symbol: Indicates Danger, Warning, Caution, or Important. Failure to read and follow the Danger, Warning, Caution, or Important indicators could result in serious injury or death to the workers and/or bystanders.

Warnings and Cautions

Read all instructions before assembling, maintaining, or repairing the QuadGuard® Elite system.



Danger: Failure to comply with these warnings could result in increased risk of serious injury or death in the event of a vehicle impact with a system that has not been accepted by the Federal Highway Administration (FHWA).



Warning: Do not assemble, maintain, or repair the QuadGuard® Elite system until you have read this Manual thoroughly and completely understand it. Ensure that all Danger, Warning, Caution, and Important statements within the Manual are completely followed. Please call Trinity Highway at (888) 323-6374 if you do not understand these instructions.



Warning: Safety measures incorporating appropriate traffic control devices specified by the highway authority must be used to protect all personnel while at the assembly, maintenance, or repair site.



Warning: Use only Trinity Highway parts that are specified herein for the QuadGuard® Elite for assembling, maintaining, or repairing the QuadGuard® Elite system. **Do not utilize or otherwise comingle parts from other systems even if those systems are other Trinity Highway systems.** Such configurations have not been tested, nor have they been accepted for use. Assembly, maintenance, or repairs using unspecified parts or accessories is strictly prohibited. Failure to follow this warning could result in serious injury or death in the event of a vehicle impact with an UNACCEPTED system.



Warning: **DO NOT** modify the QuadGuard® Elite system in any way.



Warning: Ensure that the QuadGuard® Elite system and delineation used meet all federal, state, specifying agency, and local specifications.



Warning: Ensure that your assembly meets all appropriate Manual on Uniform Traffic Control Devices (MUTCD) and local standards.



Warning: Ensure that there is proper site grading for the QuadGuard® Elite system placement as dictated by the state or specifying agency, pursuant to Federal Highway Administration (FHWA) acceptance.



Warning: Use only Trinity Highway parts on the QuadGuard® Elite system for assembly, maintenance, or repair. **The assembly or comingling of unauthorized parts is strictly PROHIBITED.** The QuadGuard® Elite and its component parts have been accepted for state use by the FHWA. However, a comingled system has not been accepted within the applicable criteria.



Important: Trinity Highway makes no recommendation whether use or reuse of any part of the system is appropriate or acceptable following an impact. It is the sole responsibility of the local highway authority and its engineers to make that determination. It is critical that you inspect this product after assembly is complete to make certain that the instructions provided in this Manual have been strictly followed.



Warning: Ensure that this assembly conforms with the guidance provided by the AASHTO Roadside Design Guide, including, but not limited to, those regarding placement on or adjacent to curbs.

Limitations and Warnings

Trinity Highway, in compliance with the National Cooperative Research Highway Program 350 (NCHRP Report 350) “Recommended Procedures for the Safety Performance of Highway Safety Features”, contracts with FHWA approved testing facilities to perform crash tests, evaluation of tests, and submittal of results to the Federal Highway Administration for review.

The QuadGuard® Elite system has been approved by FHWA as meeting the requirements and guidelines of NCHRP Report 350. These tests typically evaluate product performance defined by Report 350 involving a range of vehicles on roadways, from lightweight cars (approx. 820 kg [1800 lb.]) to full size pickup trucks (approx. 2000 kg [4400 lb.]). A product can be certified for multiple Test Levels. The QuadGuard® Elite is certified to the Test Level(s) as shown below:

Test Level 2: 70 km/h [43 mph]

Test Level 3: 100 km/h [62 mph]

These FHWA directed tests are not intended to represent the performance of systems when impacted by every vehicle type or every impact condition existing on the roadway. This system is tested only to the test matrix criteria of NCHRP Report 350 as approved by FHWA.

Trinity Highway neither represents nor warrants that the impact results of these federally established test criteria prevent or reduce the severity of any injury to person(s) or damage to property. These tests only demonstrate the occurrence of certain results following an impact within NCHRP Report 350 criteria. Every departure from the roadway is a unique event.

The QuadGuard® Elite system is intended to be assembled, delineated, and maintained within specific state and federal guidelines. It is important for the highway authority specifying the use of a highway product to select the most appropriate product configuration for its site specifications. The customer should be careful to properly select, assemble, and maintain the product. Careful evaluation of the site lay out, vehicle population type; speed, traffic direction, and visibility are some of the elements that require evaluation in the selection of a highway product. For example, curbs could cause an untested effect on an impacting vehicle.

After an impact occurs, the debris from the impact should be removed from the area immediately and the specified highway product should be evaluated and restored to its original specified condition or replaced as the highway authority determines as soon as possible.

System Overview

The QuadGuard® Elite is a potentially reusable, re-directive, non-gating crash cushion for road features ranging in width from 610 mm to 2285 mm (24" to 90"). It consists of energy absorbing cylinders surrounded by a framework of Quad-Beam™ panels. It shall be the sole discretion of the specifying highway authority as to whether or not this system is reusable or should be replaced.

The QuadGuard® Elite utilizes two (2) types of Cylinders in a “staged” configuration to address both lighter cars and heavier, high center-of-gravity vehicles. Its modular design allows the system length to be tailored to the design speed of a site.

Impact Performance

The 5 Bay and 7 Bay EC QuadGuard® Elite systems have successfully passed the requirements stipulated in NCHRP Report 350, Test Level Two (70 km/h [43 mph]).

The 8 Bay and 11 Bay EC QuadGuard® Elite systems have successfully passed the requirements stipulated in NCHRP Report 350, Test Level Three (100 km/h [62 mph]).

The “EC” designation stands for “Extra Capacity”. This system has additional energy absorbing capacity.

The 14 Bay QuadGuard® Elite has successfully been tested with a pickup truck at speeds up to 113 km/h [70 mph].

During head-on impacts, within the applicable NCHRP Report 350 criteria, the QuadGuard® Elite has been shown to telescope rearward to absorb the energy of impact. During those same in-criteria impacts, when impacted from the side, the system has been shown to redirect the vehicle back toward its original travel path and away from the roadside obstacle.

Recommended Tools

Documentation

- Manufacturer's Assembly Manual
- Manufacturer's Drawing Package

Personal Protective equipment

- Safety glasses
- Safety-toe shoes
- Gloves
- Apron for MP-3[®] application

Cutting equipment

- Rotary hammer drill
- Rebar cutting bit
- Concrete drill (double-fluted) bits – 22 mm [7/8"]
- Grinder, Hacksaw or Torch (optional)
- Drill motor
- Drill bits 1/16" through 7/8"

Note: Trinity Highway recommends using double-fluted drill bits to achieve required tensile strength when assembling the MP-3[®] anchoring system. That decision must be confirmed with the highway authority authorizing the assembly and confirming that it is assembled to their specification.

Hammers

- Sledgehammer
- Standard hammer

Wrenches

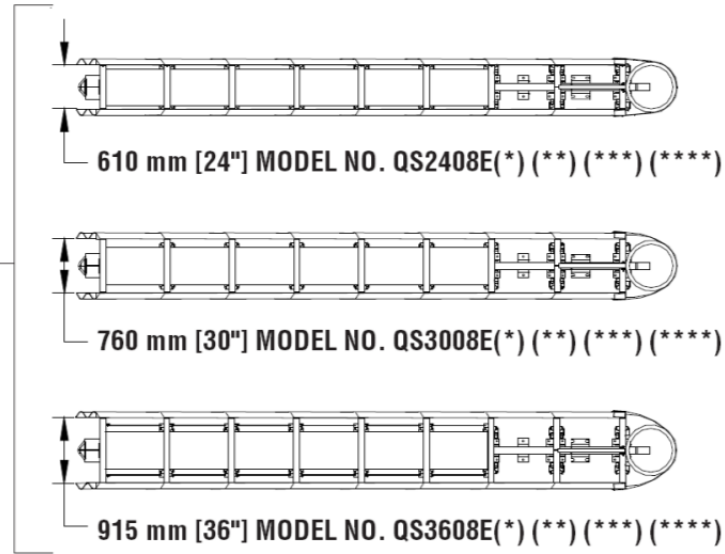
- Heavy duty impact wrench: 1/2"
- Crescent Wrench: 300 mm [12"]
- 1/2" drive Sockets: 9/16", 11/16", 3/4", 15/16", 1 1/8", 1 1/4"
- 1/2" drive Deep Sockets: 15/16", 1 1/4"
- 1/2" drive Ratchet and attachments
- 1/2" drive Breaker Bar - 24" long
- 1/2" drive Torque Wrench: 200 ft.-lbs.
- Allen Wrench: 3/8

Miscellaneous

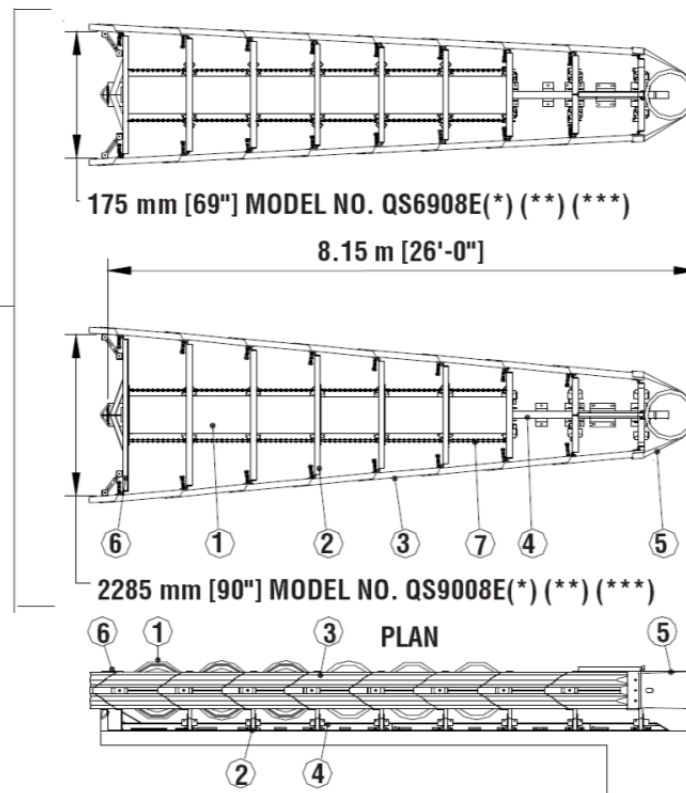
- Traffic control equipment
- Lifting and moving equipment (A lifting device is preferred although a forklift can be used.) Minimum 5,000 lb. capacity required.
- Air Compressor (100 psi) and Generator (5 kW)
- Long pry bar
- Drift pin 300 mm [12"]
- Center punch
- Tape measure 7.5 m [25']
- Chalk line
- Concrete marking pencil
- Nylon bottle brush for cleaning 7/8" drilled holes
- Rags, water, and solvent for touch-up
- Chain, 3/8" grade 40, 6 m [20'] with 13 mm [1/2"] hooks.

Note: The above list of tools is a general recommendation. Depending on specific site conditions and the complexity of the assembly specified by the appropriate highway authority, additional or fewer tools may be required. Decisions as to what tools are needed to perform the job are entirely within the discretion of the specifying highway authority and the authority's selected contractor performing the assembly of the system at the authority's specified site.

QUADGUARD ELITE
FOR NARROW HAZARDS



QUADGUARD ELITE
FOR WIDE HAZARDS



Key

- 1) Energy-Absorbing Cylinder
- 2) Diaphragm
- 3) Quad-Beam Fender Panel
- 4) Monorail
- 5) Nose Cover
- 6) Backup
- 7) Chain Assembly

- * Also Available in 5 Bay Lengths
- ** Also Available in 7 Bay Lengths (EC Model)
- *** Also Available in 11 Bay Lengths (EC Model)
- **** Also Available in 14 Bay Lengths

Figure 1
Plan and Elevation

How to Determine Left/Right

To determine left from right when ordering parts, stand in front of the system facing the fixed object. Your left is the system's left and your right is the system's right.

Counting the Number of Bays

One Bay consists of (1) Diaphragm, (2) Fender Panels, etc. The Nose Assembly is not considered a Bay (see Figure 3).

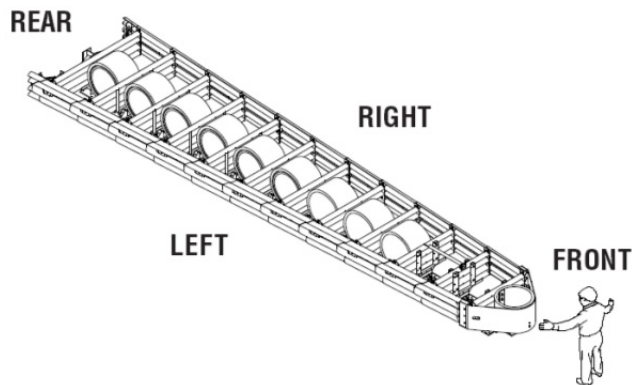


Figure 2
Left/Right

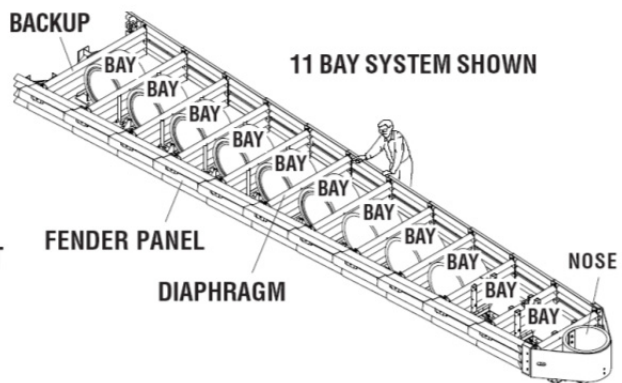


Figure 3
Number of Bays

Table A

The QuadGuard® Elite system is available in the following sizes.

System Width	5 Bay 70 km/h [43 mph]	7 Bay EC 85 km/h [53 mph]	8 Bay 100 km/h [62 mph]	11 Bay EC 105 km/h [65 mph]	14 Bay 113 km/h [70 mph]
610mm [24"]	QS2405E	QS2407E	QS2408E	QS2411E	QS2414E
760mm [30"]	QS3005E	QS3007E	QS3008E	QS3011E	QS3014E
915mm [36"]	QS3605E	QS3607E	QS3608E	QS3611E	QS3614E
1755mm [69"]	QS6905E	QS6907E	QS6908E	QS6911E	Not Available
2285mm [90"]	QS9005E	QS9007E	QS9008E	QS9011E	Not Available

The nominal width of the Tension Strut Backup is the width between Side panels behind the Backup (see Figure 4). The outside width of the system is approximately 150 mm [6"] to 230 mm [9"] wider than this measurement.

**MEASURE TENSION
STRUT BACKUP**

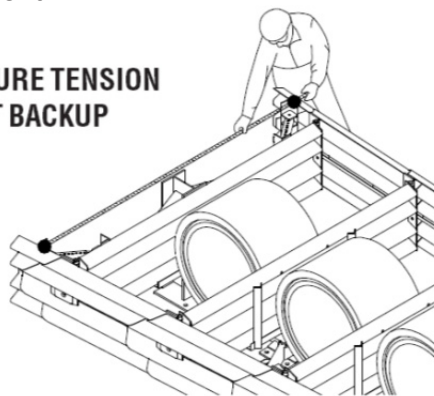
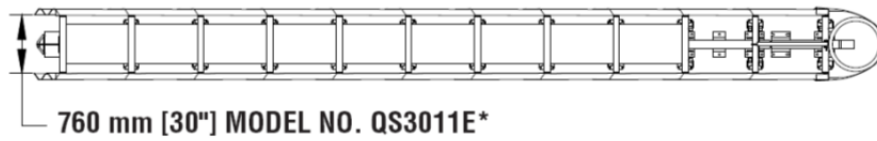
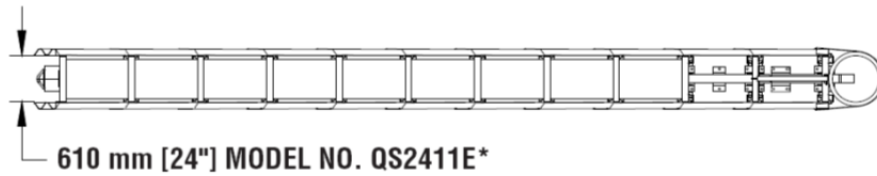


Figure 4
Tension Strut Backup Width

QuadGuard[®] Elite for Narrow Roadside Obstacles



* Also available: QS2405E, QS2407E, QS2408E, QS2414E,
QS3005E, QS3007E, QS3008E, QS3014E,
QS3605E, QS3607E, QS3608E, QS3614E

Assembly Narrow

Site Preparation/Foundation

A QuadGuard® Elite should be assembled only on an existing or freshly placed and cured concrete foundation (28 MPa [4000 psi] minimum). Location and orientation of the concrete base and attenuator must comply with project plans or as otherwise determined by the resident project engineer.

Recommended dimension and reinforcement specifications for new concrete foundations are provided in Trinity Highway Concrete Foundation drawing, supplied with the system. The system may be assembled on a non-reinforced concrete roadway (minimum 200 mm [8"] thick). Foundation cross-slope shall not exceed 8% and no more than 2% over the length of the system; the foundation surface shall have a light broom finish.



Caution: Accurate placement of all steel rebar is critical to avoid interference with the concrete anchor bolts.



Warning: Location of the Backup in relation to nearby objects will affect the operation of the attenuator. Upon impact, the Fender Panels telescope rearward and extend beyond the rigid Backup as much as 635 mm [25"] from their pre-impact location. Position the Backup so that the rear ends of the last Fender Panels are a minimum of 635 mm [25"] forward of objects that would otherwise interfere with movement of the panels. Failure to comply with this requirement is likely to result in system performance which had not been crash tested pursuant to NCHRP Report 350 criteria and may also cause component damage which will necessitate maintenance or replacement of the system.



Inspect Shipping

Before deploying the QuadGuard® Elite, check the received parts against the shipping list supplied with the system. Make sure all parts have been received.

Assembly Procedures

Note: The Drawing Assembly Package supplied with the QuadGuard® Elite must be used with these instructions for proper assembly and should take precedence over these general instructions.

1) Determine Backup and Transition Type

The QuadGuard® Elite uses a Tension Strut Backup or Concrete Backup.

A Transition Panel or Side Panel must be used for the system to perform as crash tested on each side of the Backup. A Side Panel is not needed when a Transition Panel is used. Several types of transitions are available for use with the QuadGuard® Elite. See Figures 7 through 11 and the Drawing Assembly Package to determine which type of panel to attach.

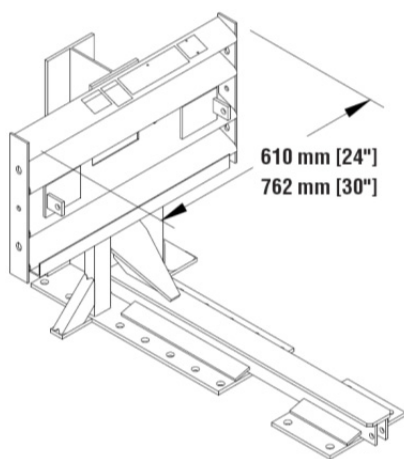


Figure 5a
Tension Strut Backup

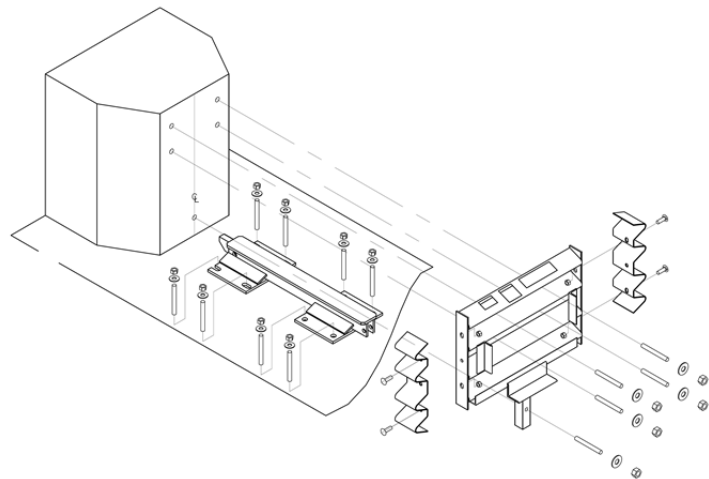


Figure 5b
Concrete Backup

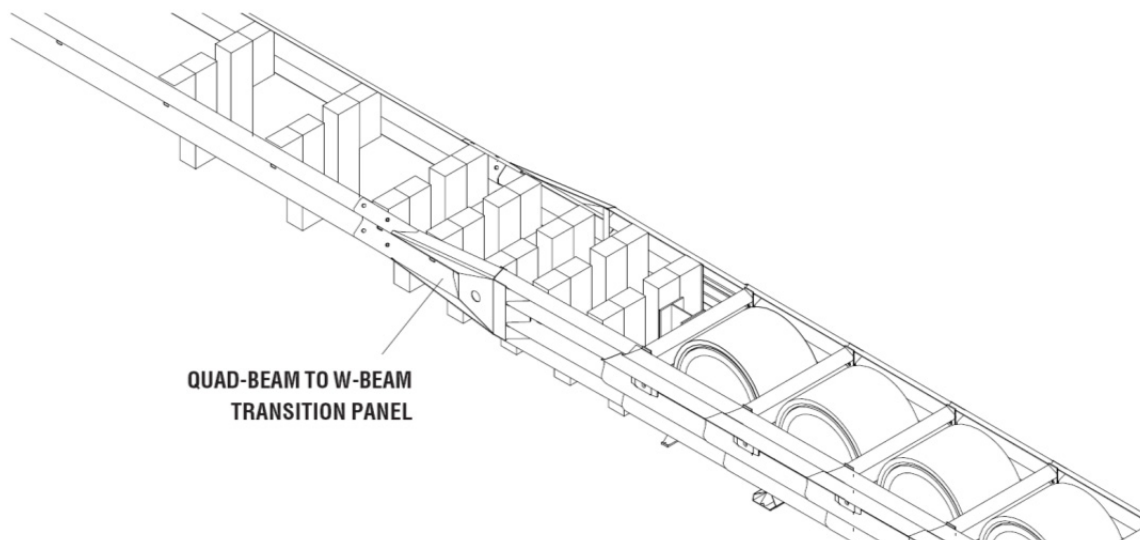


Figure 6
Transitioning the QuadGuard Elite



Figure 7
Side Panel

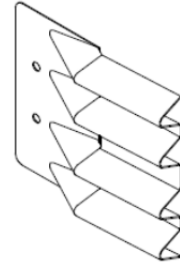


Figure 8
Quad-Beam End Shoe

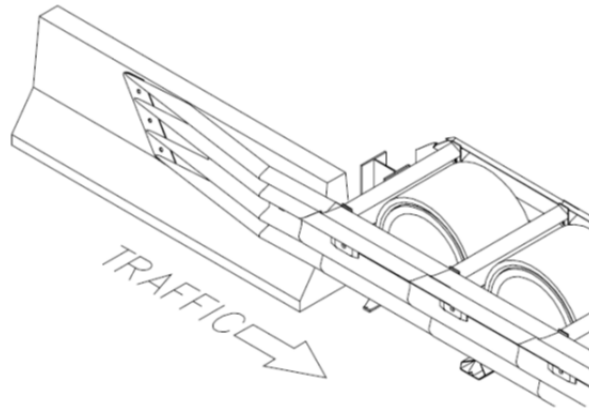


Figure 9
Quad-Beam to Safety Shape Barrier Transition Panel

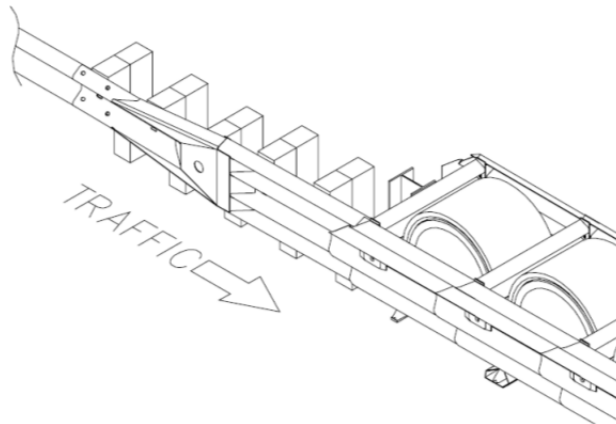


Figure 10
Quad-Beam to W-Beam Transition Panel

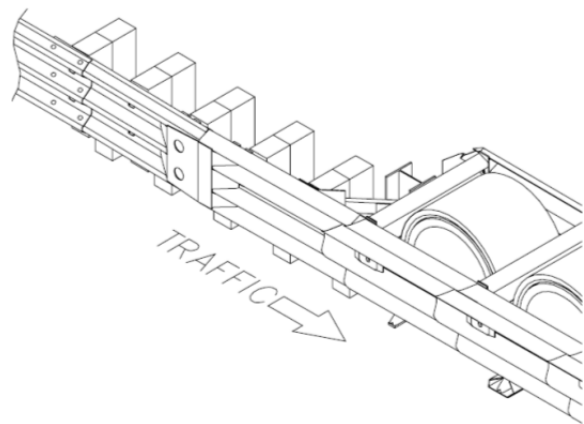


Figure 11
Quad-Beam to Thrie-Beam Transition Panel

Transition and Side Panel Types

Note: The proper Transition Panel or Side Panel must be used for proper Transition Panel impact performance of the system. The correct panel to use will depend on the direction of traffic and what type of barrier or fixed object the QuadGuard® Elite is shielding. Contact the Customer Service Department prior to assembly if you have any questions (see p. 3).

2) Mark System Location

Locate the centerline of the system by measuring the proper offset from the roadside obstacle. See the drawing package supplied with the system. Place chalk line to mark the centerline of the system. Mark a construction line parallel to the center line and offset 165 mm [6.5"] to one side as shown in Figure 12. The edge of the Monorail will be placed on this line.

Note: The concrete pad shall comply with the project plans supplied with the system.



Warning: System location with respect to the fixed object is critical and dependent on the type of Transition Panel used. See the project plans supplied with the system for details.



Figure 12
(Top view of concrete pad)
Locating Construction Line

3) Anchor the Backup and Monorail

See Figure 13 (showing Backup Assembly) and Figure 14 (showing Monorail deployment). Also refer to the drawing package and the MP-3[®] Polyester Anchoring System Instructions included with this Manual.

A) Tension Strut Backup Assembly (Figure 13)

Locate the Backup and Monorail on the pad with the side of the Monorail on the construction line (Figure 15). Verify that applicable Transition Panels fit properly before anchoring the Backup. Drill 140 mm [5 1/2"] deep anchor holes in the pad using the Backup as a template. Do not drill through pad. Anchor the Backup to the concrete pad using the MP-3[®] vertical kits provided (see "MP-3[®] Polyester Anchoring System" on p. 52).

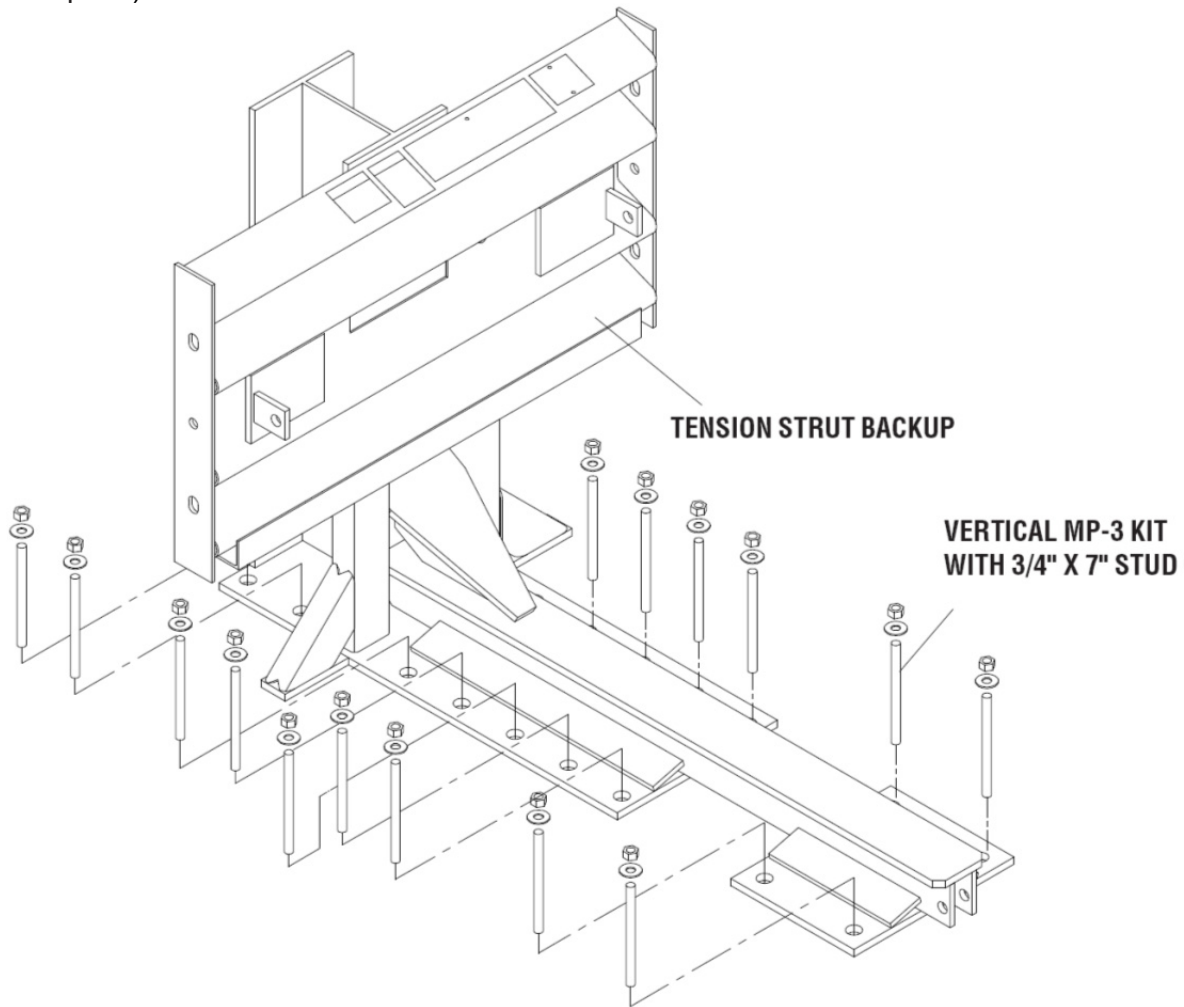


Figure 13
Anchoring Tension Strut Backup to Foundation

B) Monorail Assembly

Locate the Monorail on the construction line as shown in the Monorail Assembly drawings. Drill 140 mm [5 1/2"] deep anchor holes using the Monorail as a template (see Figure 15). Do not drill through pad. Anchor each Monorail section using the MP-3[®] vertical kits provided. See Figure 15 and the MP-3[®] Polyester Anchoring System Instructions included with this Manual. It is important to attach each segment of Monorail in alignment from the back to the front of the system (± 6 mm [1/4"]).



Warning: Improper alignment at the Monorail Splice Joints will prevent proper system collapse during a NCHRP Report 350 in-criteria impact.



Warning: Every hole and slot in Backup and Monorail must have an MP-3[®] stud anchoring it.

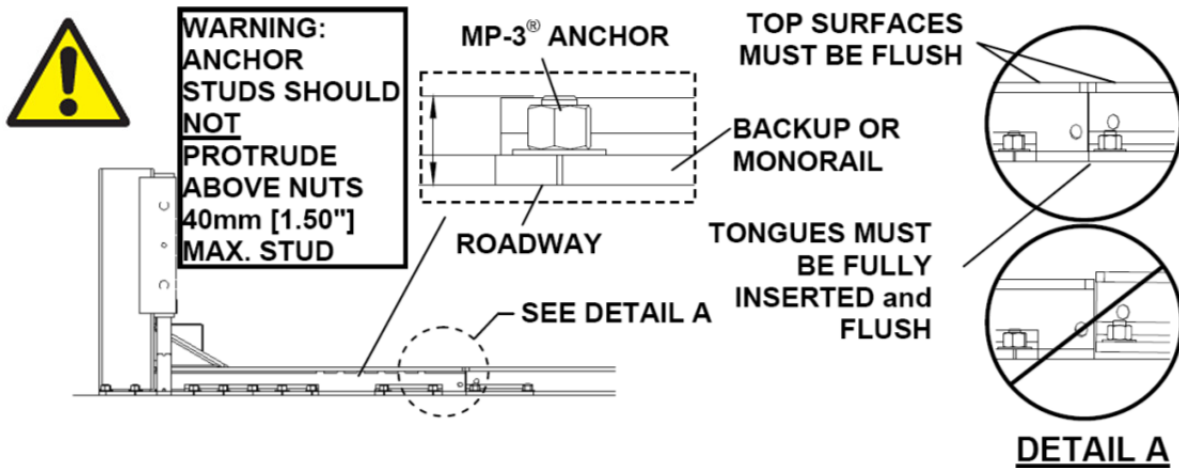


Figure 14
Proper Stud Height

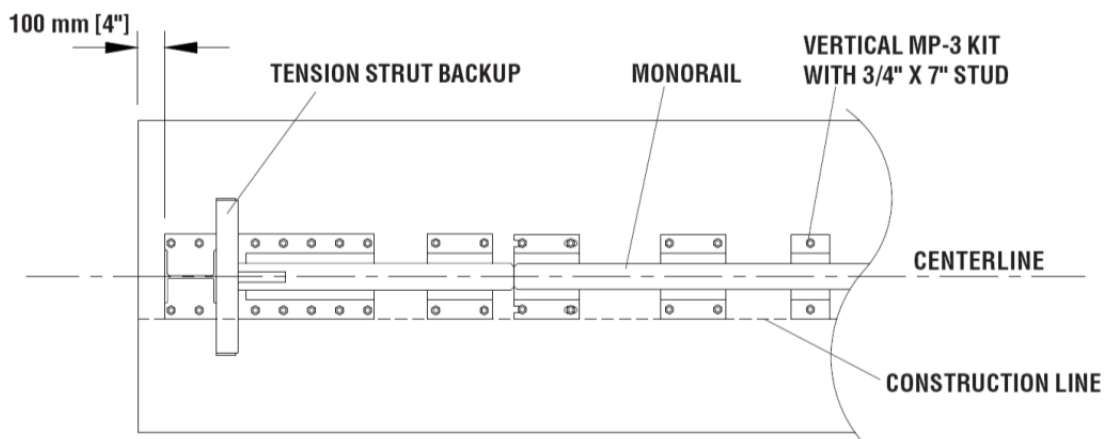


Figure 15
Backup and Monorail Location for Tension Strut Backup

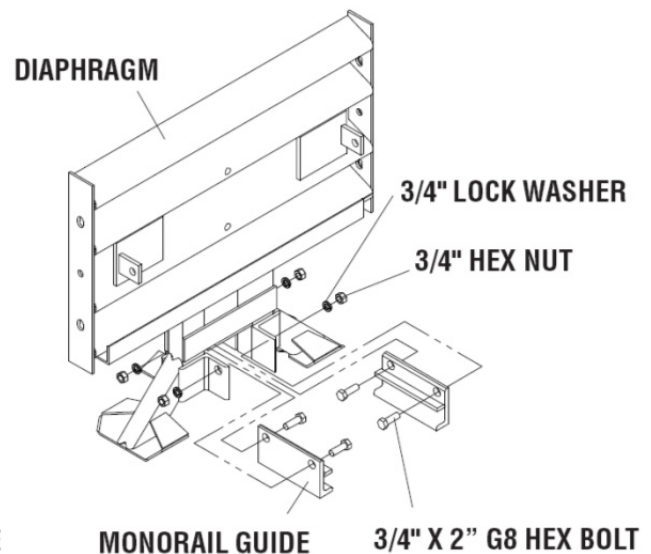
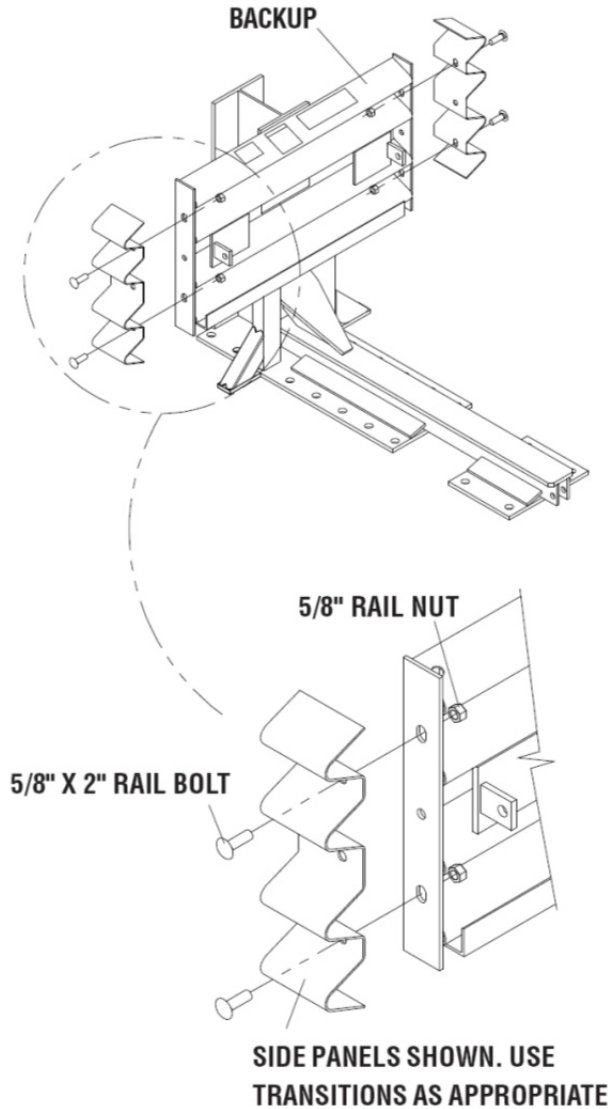
4) Attach Side Panels / Transition Panels to Backup Assembly

Attach the Transition Panel or Side Panel as appropriate to each side of the Backup. Refer to Figure 16 and the drawing package for more information.

Note: A Side Panel is not needed when a Transition Panel is used.

5) Attach Monorail Guides

Attach Monorail Guides to Diaphragms as shown in Figure 17, and the Diaphragm Assembly drawing.



6) Deploy Diaphragms

Orient a Diaphragm so that the front face of the Quad-Beam shape faces toward the Nose of the system as shown in Figure 18. Slide one Diaphragm all the way to the Backup to ensure the system is able to collapse properly during impact. Once this has been verified, slide the Diaphragm forward to approximately 915 mm [36"] in front of the Backup. Orient and slide all other Diaphragms (except the first three) onto Monorail and position each approximately as shown in Figure 19.

Diaphragms 1, 2 and 3 each have Bumpers attached to them. Orient Diaphragms 3, 2 and 1 with the Bumpers as shown in Figure 19 and the front face of the Quad-Beam shape facing toward the Nose of the system as shown in Figures 18 and 19.

Slide Diaphragms 3, 2 and 1 onto the Monorail and space as shown in Figure 19.

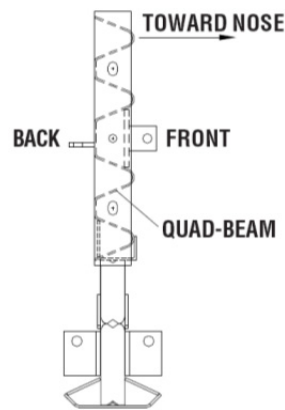


Figure 18
Diaphragm Orientation

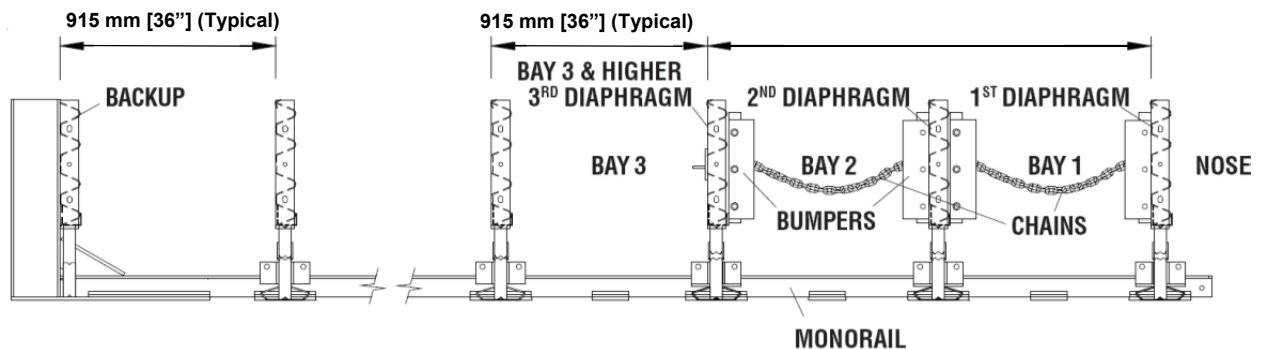


Figure 19
Diaphragm spacing

7) Cylinder Assembly

All QuadGuard Elite systems utilize a specific Cylinder configuration. Each system may be equipped with up to two (2) different types of Cylinders. See illustration on page 22 with corresponding Cylinder configuration depending on the number of Bays.

Bays 1 and 2 are always empty.

Bays 3 to 5 contain a single walled 813 mm [32"] outside diameter Cylinder with QE1 stenciled on the outer surface (see p. 22).

When systems have more than five Bays, the remaining Bays contain double walled 813 mm [32"] outside diameter Cylinders with QE2 stenciled on the outer surface (see p. 22).

Note: The Nose Assembly contains a single walled 711 mm [28"] outside diameter Cylinder with QEN (QuadGuard Elite Nose) stenciled on the outer surface.



Warning: Placing the wrong Cylinder in the Nose or any Bay has not been crash tested pursuant to NCHRP Report 350 criteria. Accordingly, this is likely to result in unacceptable crash performance as described in NCHRP Report 350.

8) Place Rear-most Cylinder

Beginning at the Backup, locate and position a Cylinder such that it is centered resting on the Monorail. Slide the rear-most Diaphragm towards the Cylinder such that no gaps exist between the backup, the Cylinder, and the Diaphragm. Wrap the 13 mm [1/2"] diameter wire rope around the back face of the Backup structure, the Cable Jacketing Tube, and the center of the Cylinder as shown in Figure 20. Attach ends of cable using (2) 13 mm [1/2"] Cable Clamps as shown in Figure 21. The Cable Clamps should be separated by approximately 102 mm [4"] as shown. Take any excess slack out of the cable prior to tightening the Cable Clamps evenly and torque nuts to 88 N-m [65 ft-lb].

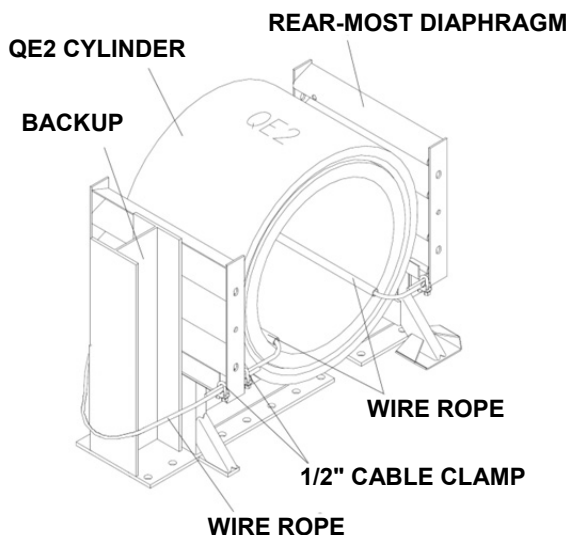


Figure 20
Cylinder Assembly
(Fender panels not shown for clarity)

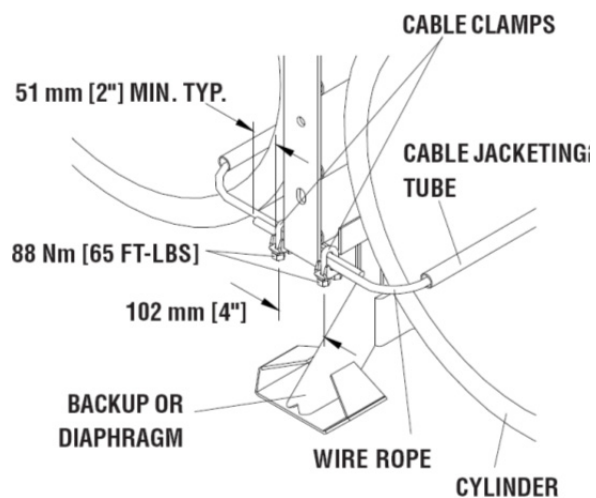


Figure 21
Typical Cable Clamp Assembly
(Fender panels not shown for clarity)

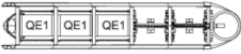
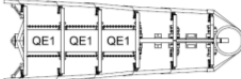

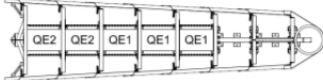

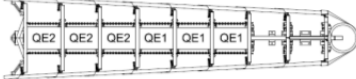

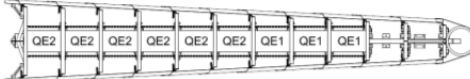


CYLINDER CONFIGURATION	
5 BAYS 	
7 BAYS 	
8 BAYS 	
11 BAYS 	
14 BAYS 	



Figure 22
QE1 and QE2 Cylinders w/Labels

9) Attach the Remaining Cylinders

Continue attaching the Cylinders to their common Diaphragms using the 1/2" cable, Cable Clamps, and Cable Jacketing Tube as shown in Figure 21. Work forward from the Backup. Be sure to remove any clearance between the Cylinders and their adjacent Diaphragms prior to removing all the possible cable slack and tightening the Cable Clamps. Except where otherwise noted, the Cable Jacketing Tube should be centered within the length of the Cylinders as shown to prevent the cable from damaging the Cylinders.

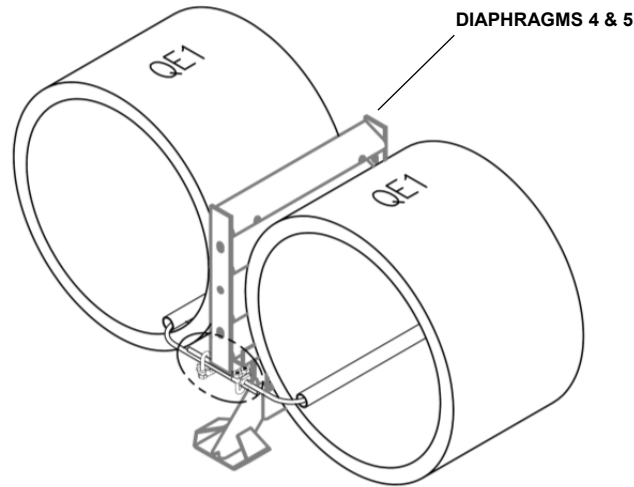


Figure 23a
Typical Cylinder Mounting

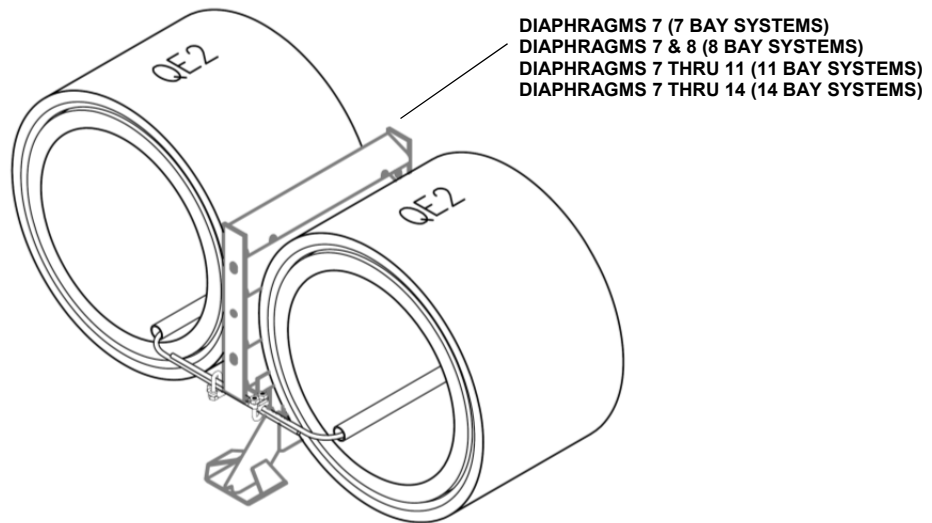


Figure 23b
Typical Cylinder Mounting

10) Attach the QE1 Cylinders

There is no Cylinder in Bays 1 and 2, therefore the 1/2" diameter cable just wraps around the legs on the front of the third Diaphragm (see Figure 23c on p. 24).

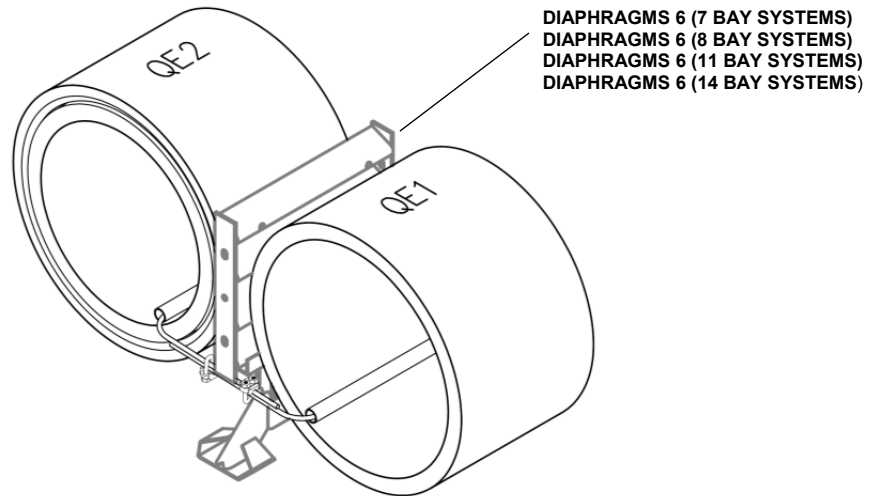


Figure 23c
QE1 Cylinder Mounting to 3rd Diaphragm

11) Attach End Cap

Attach End Cap to the Monorail as shown in Figure 24 and the Monorail Assembly drawing.

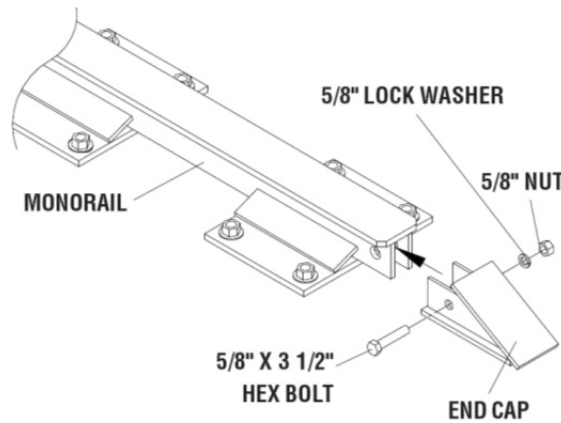


Figure 24
End Cap Attachment

12) Attach Fender Panels

Note: Do not mix the 5/8" rail nuts (large) with the 5/8" hex nuts (small) (see Figure 25).

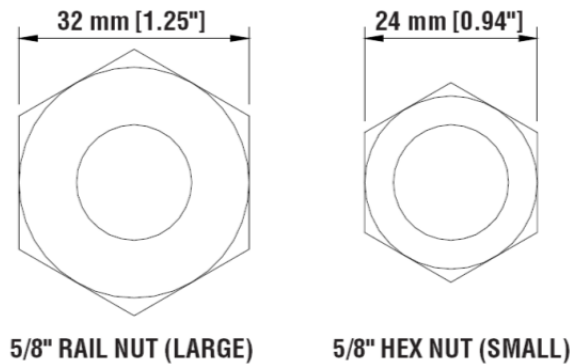


Figure 25
Rail Nuts are Oversized

Starting at the Backup and working forward, assemble left and right Fender Panels as shown in Detail 26a and Fender Panel drawing.

Step 1

Place the Fender Panel so that the center hole of the rearward Diaphragm is lined up with the approximate center of the slot in the Fender Panel.

Attach Mushroom Washer Assembly as shown in Detail 26a but do not torque at this time (this helps to balance the Fender Panel).

Step 2

Slide the Fender Panel forward until the holes in the Fender Panel line up with the holes in the forward Diaphragm.

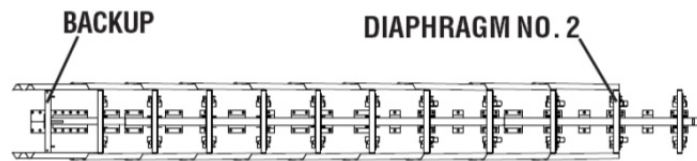
Step 3

Use a drift pin to align the center hole of the Fender Panel with the center hole of the Diaphragm.

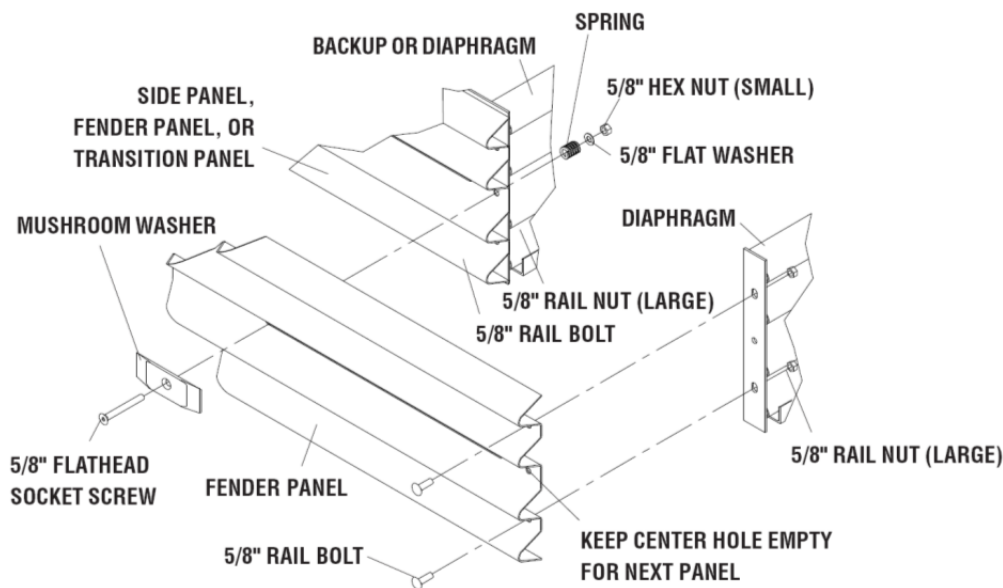
Step 4

Attach the front of the Fender Panels to the next Diaphragm using (2) rail bolts and large hex nuts per side. Use only the top and bottom holes; leave the center hole open until the next Fender Panel is attached.

Continue attaching Fender Panels until you reach Diaphragm No. 2. Figure 26 shows the location of Diaphragm No. 2.

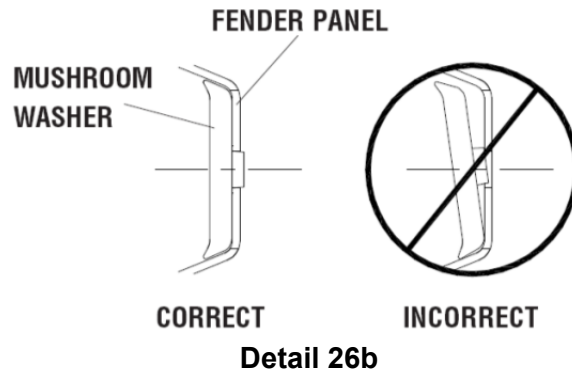


**Figure 26
Locate Diaphragm No. 2**



**Detail 26a
Fender Panel Assembly**

Be sure Mushroom Washers lay flat against the Fender Panel as shown below. Standoff on Washer must be seated completely through slot (see Detail 26b).



13) Attach Nose Cylinder

Attach the Nose Cylinder using (2) 5/8" x 7" long threaded rods through the Nose Cylinder Plate, Nose Cylinder, Diaphragm, and Chain Mount Bracket (see Figure 27). Secure each 5/8" threaded rod with flat washers, lock washers, and nuts (torque to 27 N-m [20 ft-lb] minimum, 34 N-m [25 ft-lb] maximum).

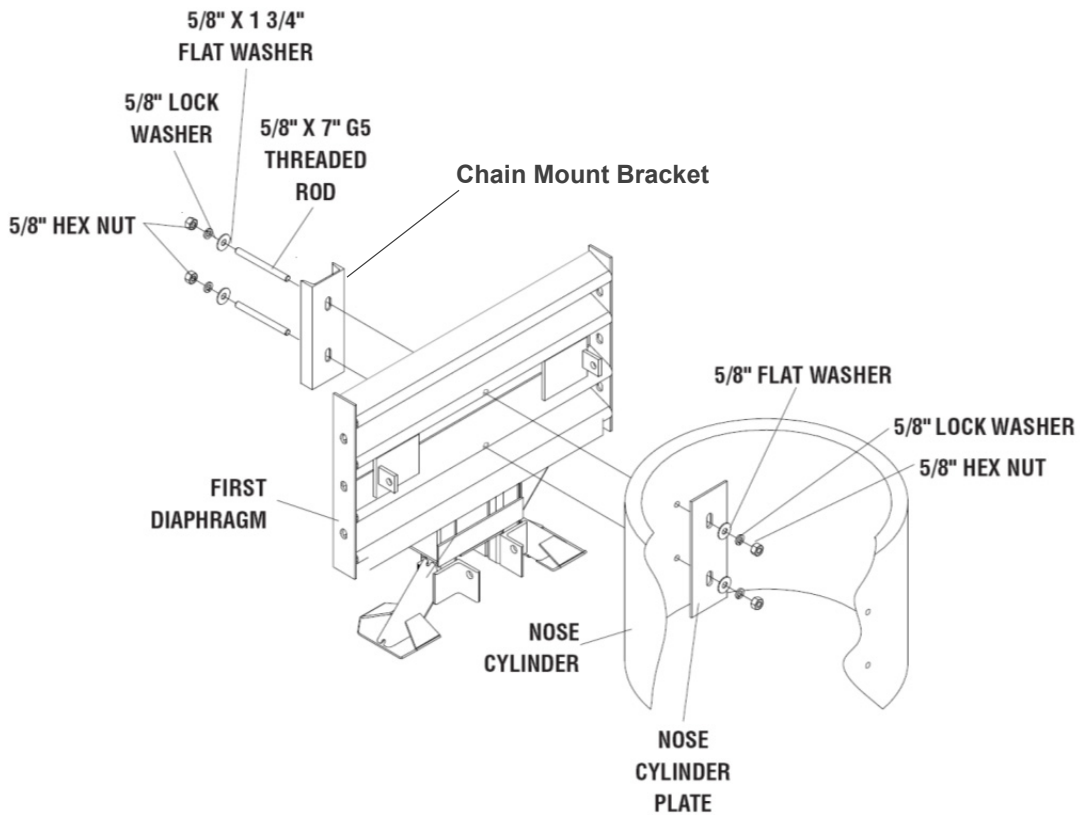
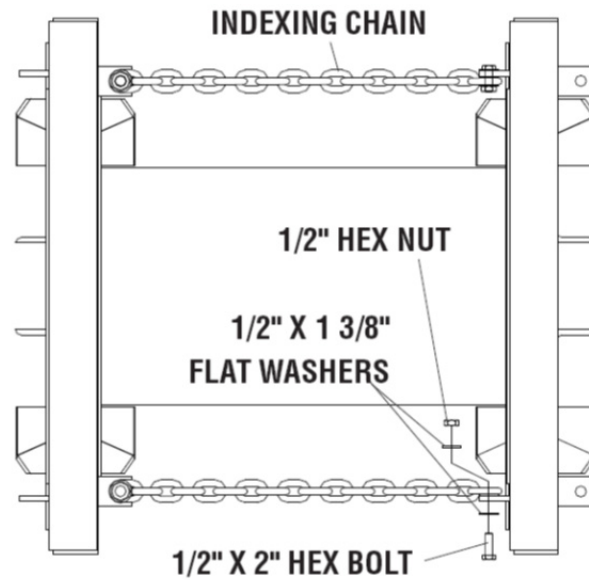


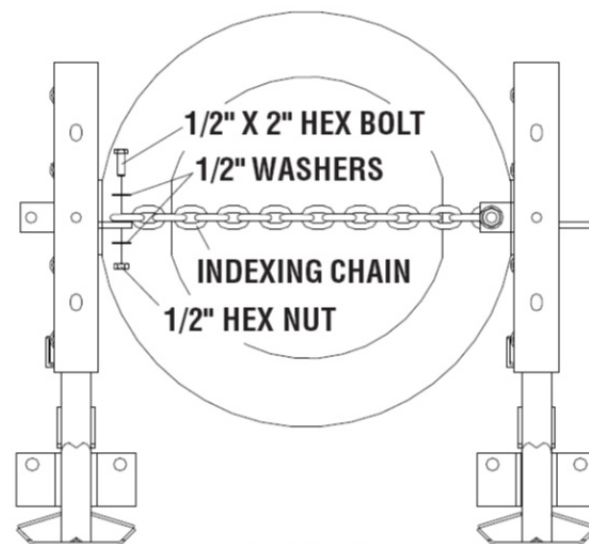
Figure 27
Attach Nose Cylinder to First Diaphragm

14) Attach Indexing Chains

For the 36" system, Bays three and higher toward the backup use (2) Indexing Chains in each Bay.



TOP VIEW



SIDE VIEW

Figure 28
Attach Indexing Chains
(Fender Panels not shown for clarity)

For the 24", 30" and 36" systems Bays 1 and 2, use one Indexing Chain in each Bay. Attach Indexing Chains using 1/2" diameter x 2" long hex head bolts, nuts and washers (see Figure 29).

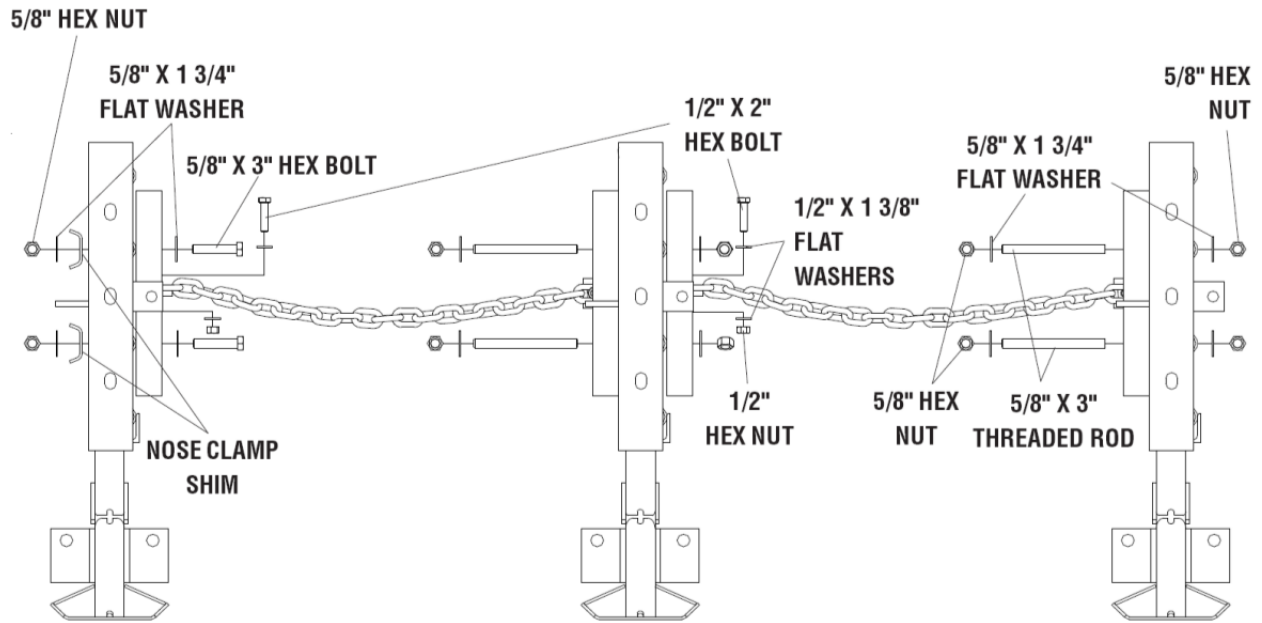


Figure 29

15) Assemble Bumper Belt Assemblies

Bays 1 and 2 of the 24", 30", and 36" wide systems are outfitted with Bumper Belt Assemblies as shown in Figure 30 and Detail 30a, 30b, and 30c. Assemble (2) Bumper Belt assemblies to the back of the first Diaphragm and the front of the third Diaphragm. First, orient Tube Spacers so the larger holes face out as shown in Detail 30c and attach the Tube Spacers to the Diaphragms using the (2) 1/2" x 2" hex bolts, nuts, and 1/2" x 1 3/8" flat washers. Next, attach one side of the flexible Bumper Belt to a Tube Spacer using (3) 3/8" x 4 1/2" long mounting bolts. Wrap the Bumper Belt around the Tube Spacer affixing its opposite side with the nut/washer combination shown in Detail 30a and 30c. Torque the mounting bolts to 37 N-m [20 ft-lb]. The second Diaphragm uses 1/2" x 5" Hex Bolts, nuts, and washers to attach Tube Spacers to each side of the Diaphragm. Repeat flexible Bumper Belt Assembly for each Tube Spacer. Attach Fender Panels including the stop tabs on the second and third Diaphragm.

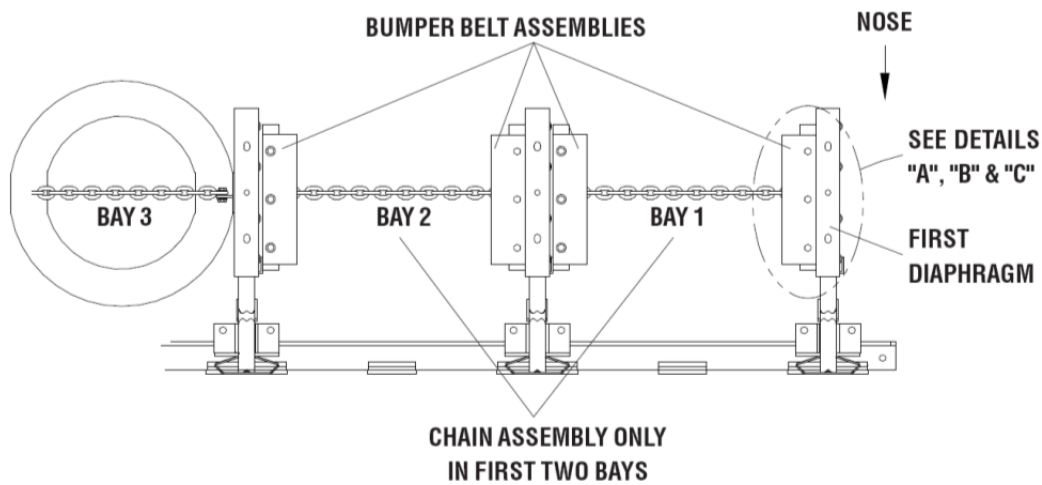
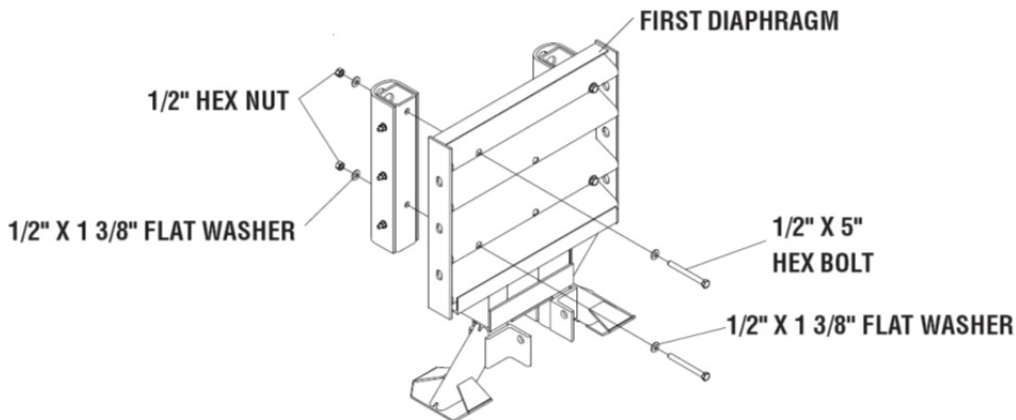
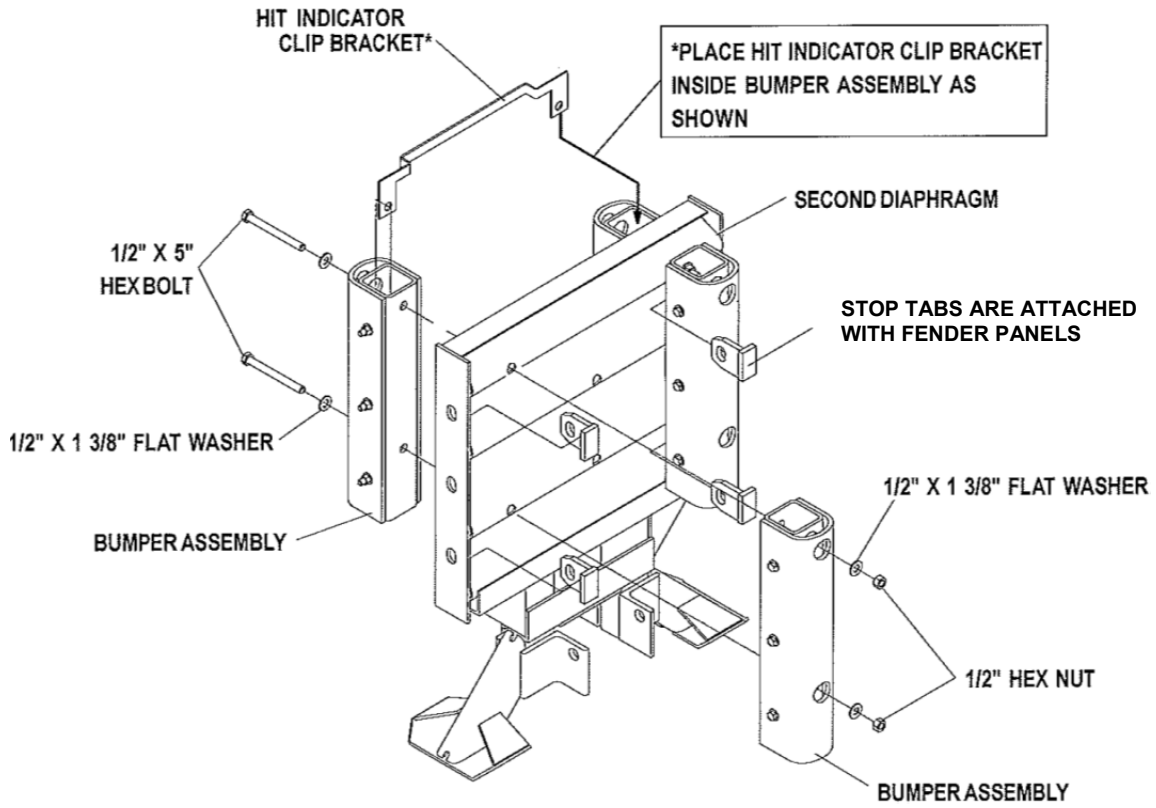


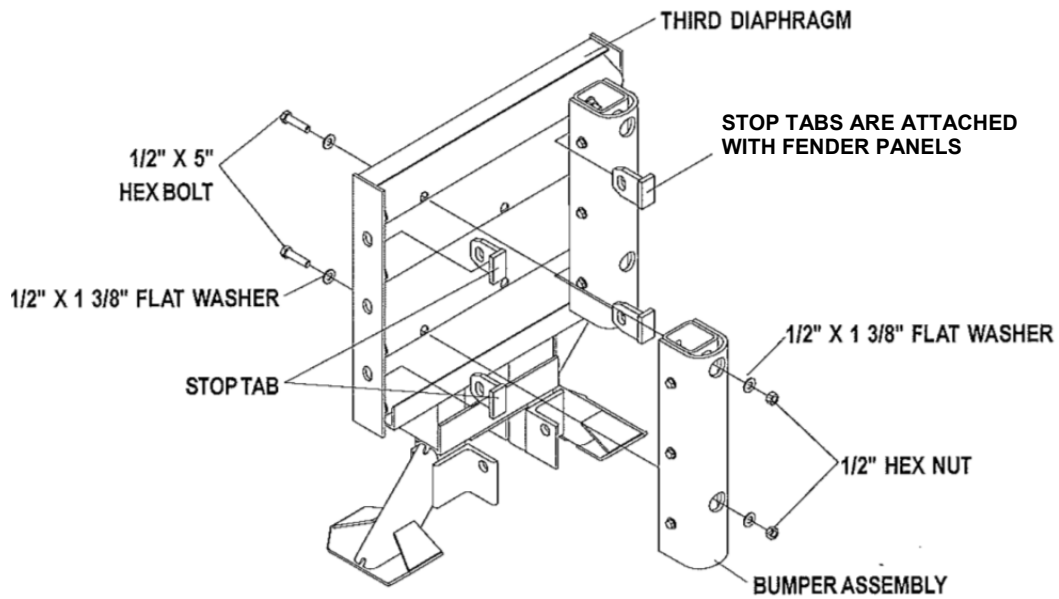
Figure 30
Bumper Belt Assembly



Detail 30a



Detail 30b



Detail 30c

16) Attach Nose Belt

Finally attach the Nose Belt to the Fender Panels using (6) 5/8" x 2" long hex head bolts, (24) 5/8" flat washers, and (18) 5/8" hex nuts through the Belt Clamps (see Figure 28).

The Nose of the system may be delineated to comply with local codes (chevron, reflectorized sign, etc.).



Warning: Placing the wrong type Cylinder in the Nose or any Bay **will** result in unacceptable crash performance as described in NCHRP Report 350.

Adjust the hex nuts so that the faces of the flat washers are flush with the outside humps of the Fender Panels (see Figure 31).

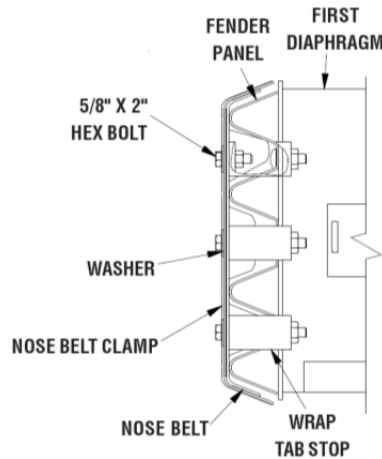


Figure 31

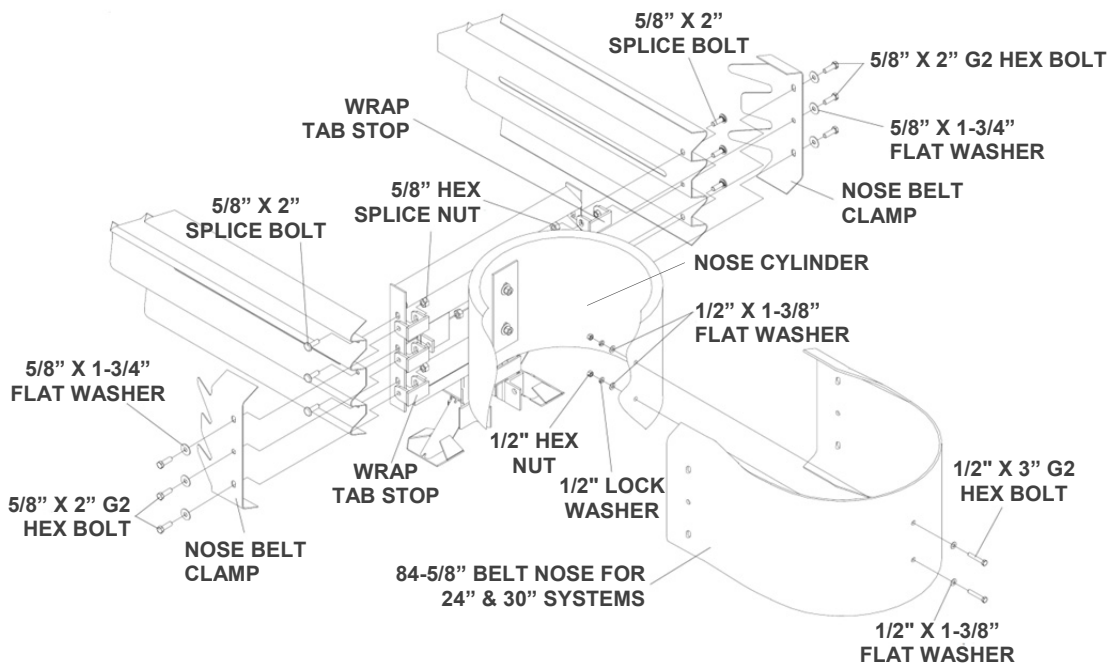


Figure 32
Attach Nose Belt to Fender Parts

17) Attach Hit Indicator to Diaphragm No. 1

The Hit Indicator should be the last component attached to the system. Center and bolt the Hit Indicator to the first Diaphragm with the hardware provided as shown in Figure 33.

Rotate the Hit Indicator to its horizontal position and lock it into position by bending the Trigger Clip around the top of the second Diaphragm (see Figure 34).

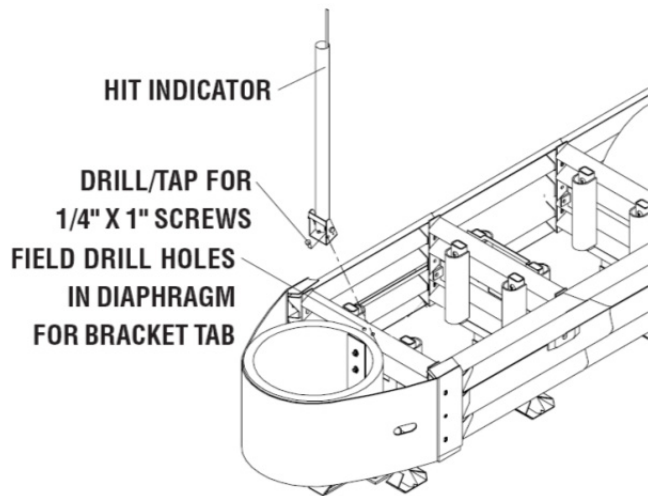


Figure 33
Attach Hit Indicator

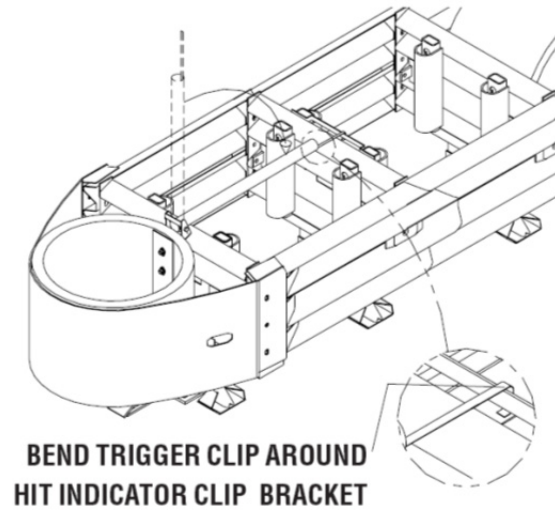


Figure 34
Rotate Hit Indicator/Bend Trigger Clip

18) Checking The System Assembly

At this point tighten all Mushroom Bolts and recheck to ensure that all fasteners are properly tightened throughout the system (anchor bolts, etc.) (see Table B). Check all Fender Panels. If they do not fit tightly against the underlying panel, system realignment may be necessary (see Figure 35).

Table B
Bolt Torque Specifications



Warning:

Anchor Studs	Torqued to 165 N-m [120 ft-lb] May slightly protrude above nuts (see Figure 14 on p. 18)
All Other Bolts	Tightened
Fender Panel	Maximum gap allowed: Narrow Systems – 20 mm [0.78"]
Cable Clamps	Torqued to 84 N-m [65 ft-lb]

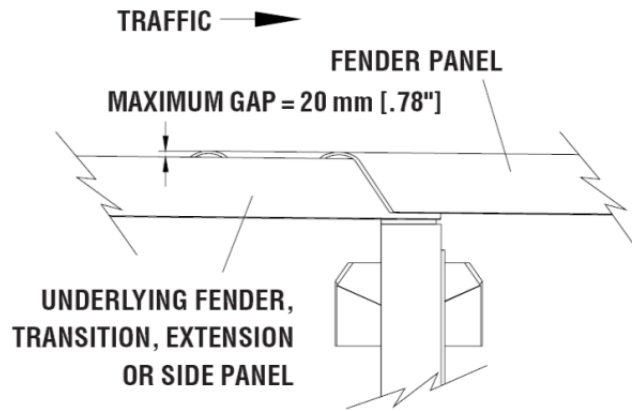


Figure 35
Fender Panel Gap for Narrow Systems

19) Inspect System

Inspect the system in accordance with the QuadGuard® Elite Maintenance Flow Chart on page 66.

QuadGuard® Elite for Wide Roadside Obstacles



Assembly Wide

Site Preparation/Foundation

A QuadGuard® Elite should be deployed only on an existing or freshly placed and cured concrete base (28 MPa [4000 psi] minimum). Location and orientation of the concrete base and attenuator must comply with project plans or as otherwise determined by the resident project engineer.

Recommended dimension and reinforcement specifications for new concrete pads are provided in Trinity Highway concrete pad drawing supplied with this system. The system may be deployed on a non-reinforced concrete roadway (minimum 200 mm [8"] thick). Concrete base cross-slope shall not exceed 8% and no more than 2% over the length of the system; the foundation surface shall have a light broom finish.



Caution: Accurate placement of all steel rebar is critical to avoid interference with the Concrete Anchor Bolts.



Warning: Location of the Backup in relation to nearby objects will affect the operation of the attenuator. Upon impact, the Fender Panels telescope rearward and extend beyond the rigid Backup as much as 635 mm [25"] from their pre-impact location. Position the Backup so that the rear ends of the last Fender Panels are a minimum of 635 mm [25"] forward of objects that would otherwise interfere with movement of the panels. Failure to comply with this requirement is likely to result in system performance which has not been crash tested pursuant to NCHRP Report 350 criteria and may also cause component damage which will necessitate maintenance or replacement of the system.

Inspect Shipping

Before deploying the QuadGuard® Elite, check the received parts against the shipping list supplied with the system. Make sure all parts have been received.

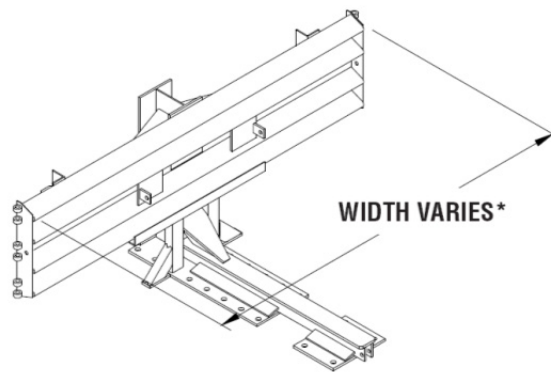
Assembly Procedures

Note: The Drawing Package supplied with the QuadGuard® Elite must be used with these instructions for proper assembly and should take precedence over these general instructions.

1) Determine Backup and Transition Type

The QuadGuard® Elite uses a Tension Strut Backup.

A Transition Panel or Side Panel must be used for the system to perform as crash tested on each side of the backup. A side panel is not needed when a Transition Panel is used. Several types of transitions are available for use with the QuadGuard® 69/90 Elite system. Refer to Figures 38 through 42 and the Drawing Assembly Package to determine which types of panels are being attached.



* 1620 mm [64"] FOR 1755 mm [69"] WIDE SYSTEM
2100 mm [83"] FOR 2285 mm [90"] WIDE SYSTEM

Figure 36
Tension Strut Backup

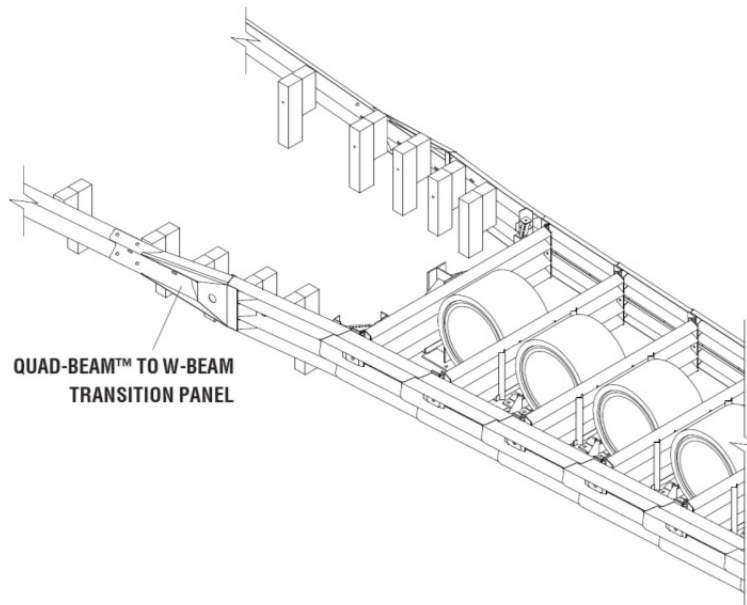


Figure 37
Transitioning the QuadGuard® Elite



Figure 38
Wide Side Panel

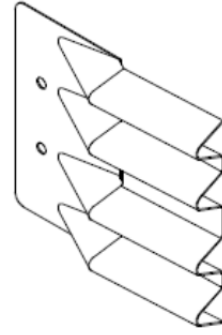


Figure 39
Quad-Beam™ End Shoe

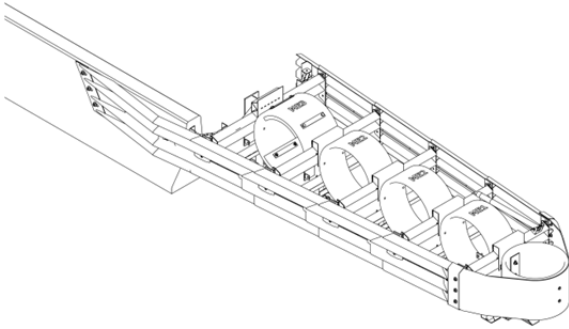


Figure 40
Quad-Beam™ to Safety Shape Barrier
Transition Panel

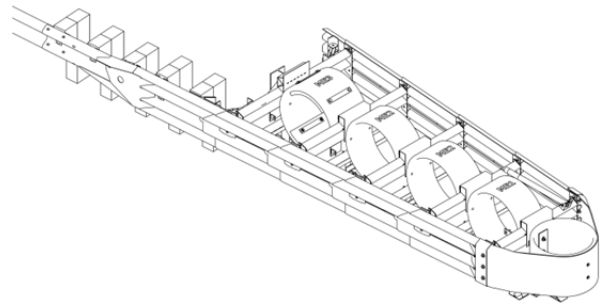


Figure 41
Quad-Beam™ to W-Beam
Transition Panel

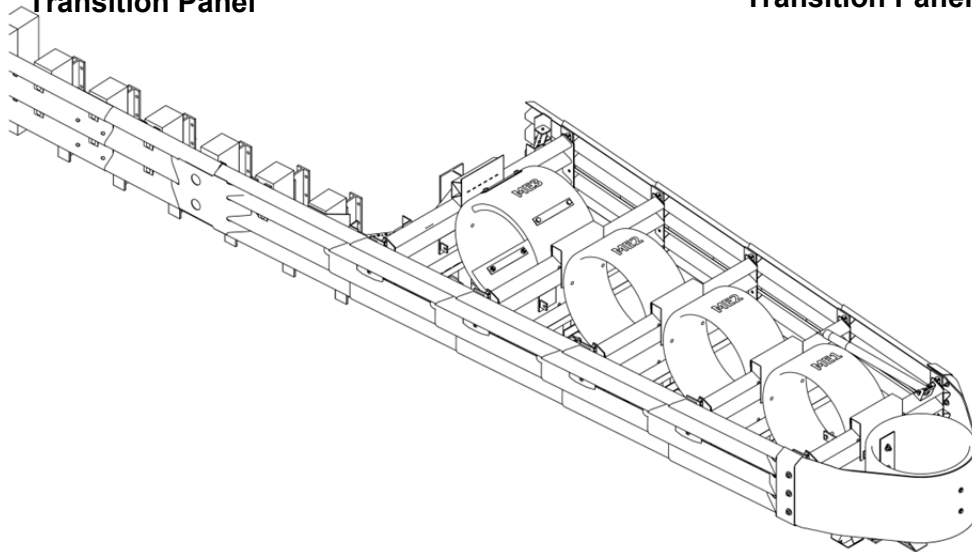


Figure 42
Quad-Beam™ to Thrie-Beam Transition Panel



Important: The proper Transition Panel or Side Panel must be used for intended impact performance of the system. The correct panel to use will depend on the direction of traffic and what type of barrier or fixed object the QuadGuard® Elite is shielding. Contact the Customer Service Department prior to deployment if you have any questions.

2) Mark System Location

Locate the centerline of the system by measuring the proper offset from the roadside obstacle. Refer to the drawing package supplied with the system. Place chalk line to mark the centerline of the system. Mark a construction line parallel to the center line and offset 165 mm [6.5"] to one side as shown in Figure 43. The edge of the Monorail will be placed on this line.

Note: The concrete pad should be configured per the project plans supplied with the system.



Warning: Location of system with respect to the road feature is critical and dependent of the type of Transition Panel used. See the project plans supplied with the system for details.



Figure 43
(Top view of Concrete Pad)
Locating Construction Line

3) Anchor the Backup and Monorail

See Figure 44 (showing Backup Assembly) and Figure 45 (showing Monorail diagram). Also see the drawing package and the MP-3[®] Polyester Anchoring System Instructions included with this Manual.

A) Tension Strut Backup Assembly (Figure 36 on page 35)

Locate the Backup and Monorail on the centerline of the pad with the side of the Monorail on the construction line (Figure 44). Verify that applicable Transition Panels fit properly before anchoring the Backup. Drill 140 mm [5 1/2"] deep anchor holes in the pad using the Backup as a template. Do not drill through pad. Anchor the Backup to the concrete pad using the MP-3[®] Vertical Kits provided (see MP-3[®] anchoring p. 52).

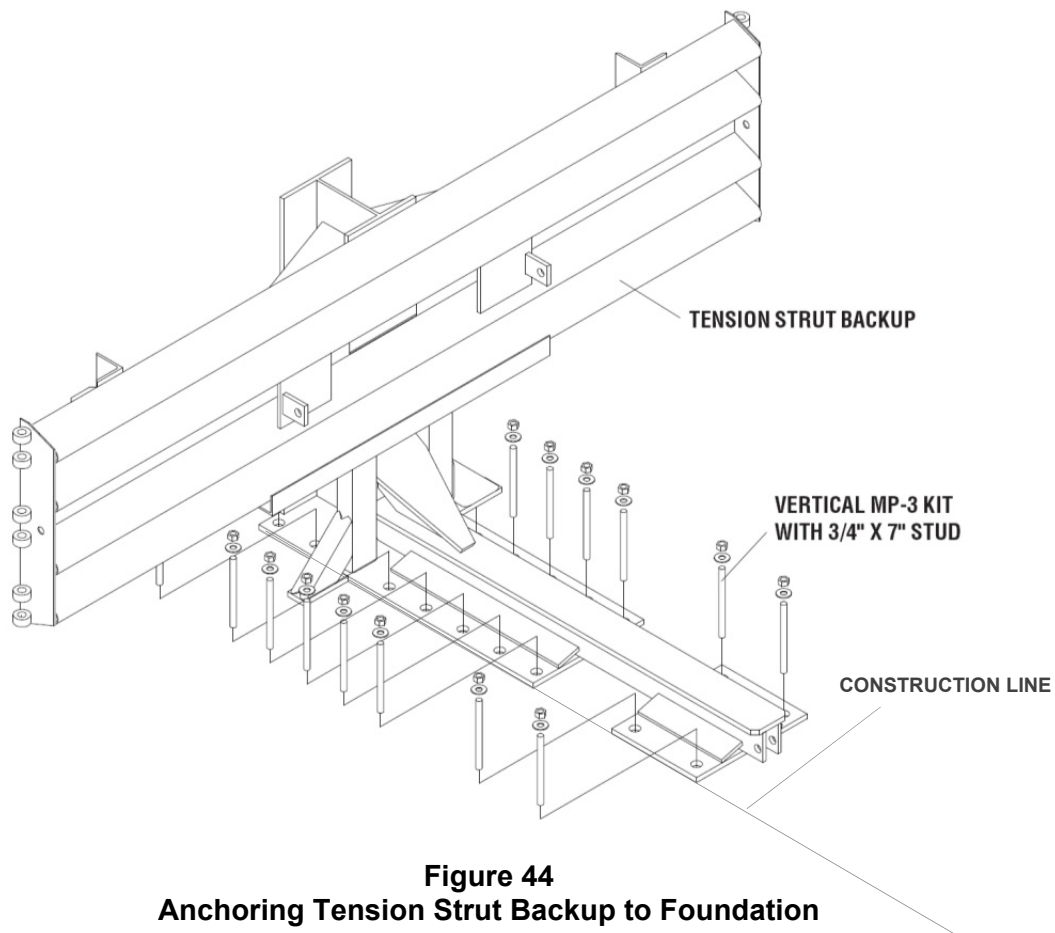


Figure 44
Anchoring Tension Strut Backup to Foundation

B) Monorail Assembly

Locate the Monorail on the construction line as shown in the Monorail Assembly drawings. Drill 140 mm [5 1/2"] deep anchor holes using the Monorail as a template (see Figure 46). Do not drill through pad. Anchor each Monorail section using the MP-3[®] Vertical Kits provided. See Figure 45 and the MP-3[®] Polyester Anchoring System Instructions included with this Manual. It is important to assemble each segment of Monorail in alignment from the back to the front of the system (± 6 mm [1/4"]).



Warning: Improper alignment at the Monorail Splice Joints **will** prevent proper system collapse during a NCHRP Report 350 in-criteria impact.



Warning: Every hole and slot in Backup and Monorail must have an MP-3[®] stud anchoring it.

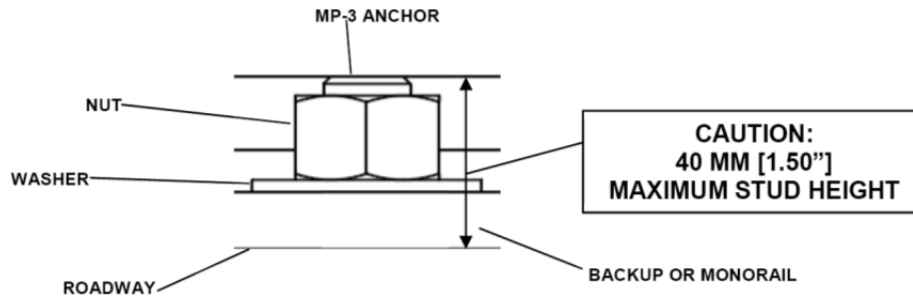


Figure 45
Proper Stud Height

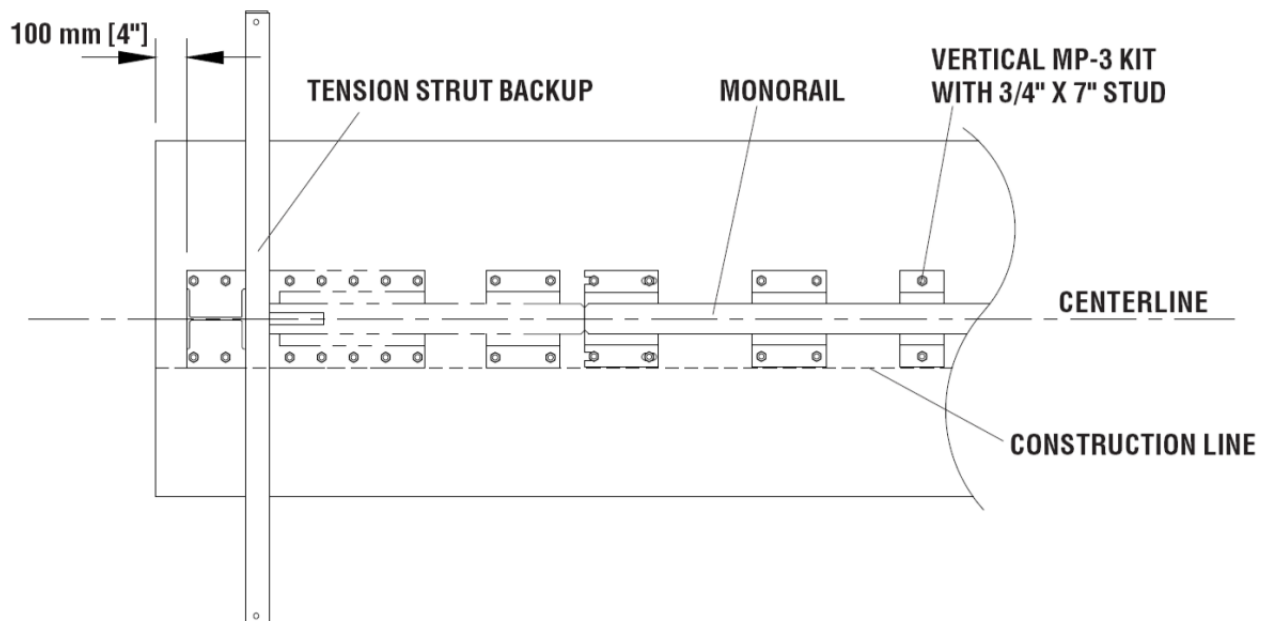


Figure 46
Backup and Monorail Location for Tension Strut Backup

4) Attach Side Panels / Transition Panels to Backup Assembly

Attach the Transition Panel or Side Panel as appropriate to each side of the Backup. See Figure 49 and drawing package for more information.

Note: A Side Panel is not needed when a Transition Panel is used.

5) Attach Monorail Guides

Attach Monorail Guides to Diaphragms as shown in Figure 47 and the Diaphragm Assembly drawing.

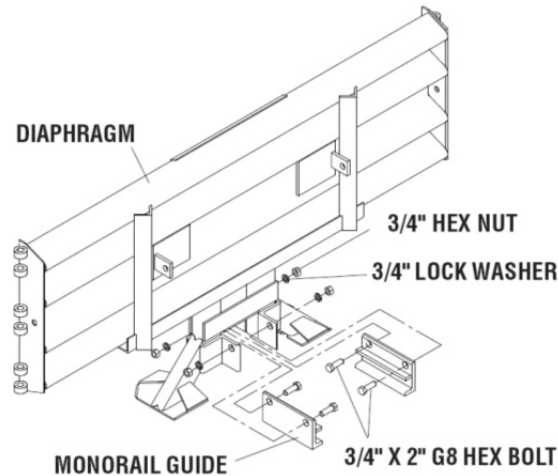


Figure 47
Monorail Guide Attachment

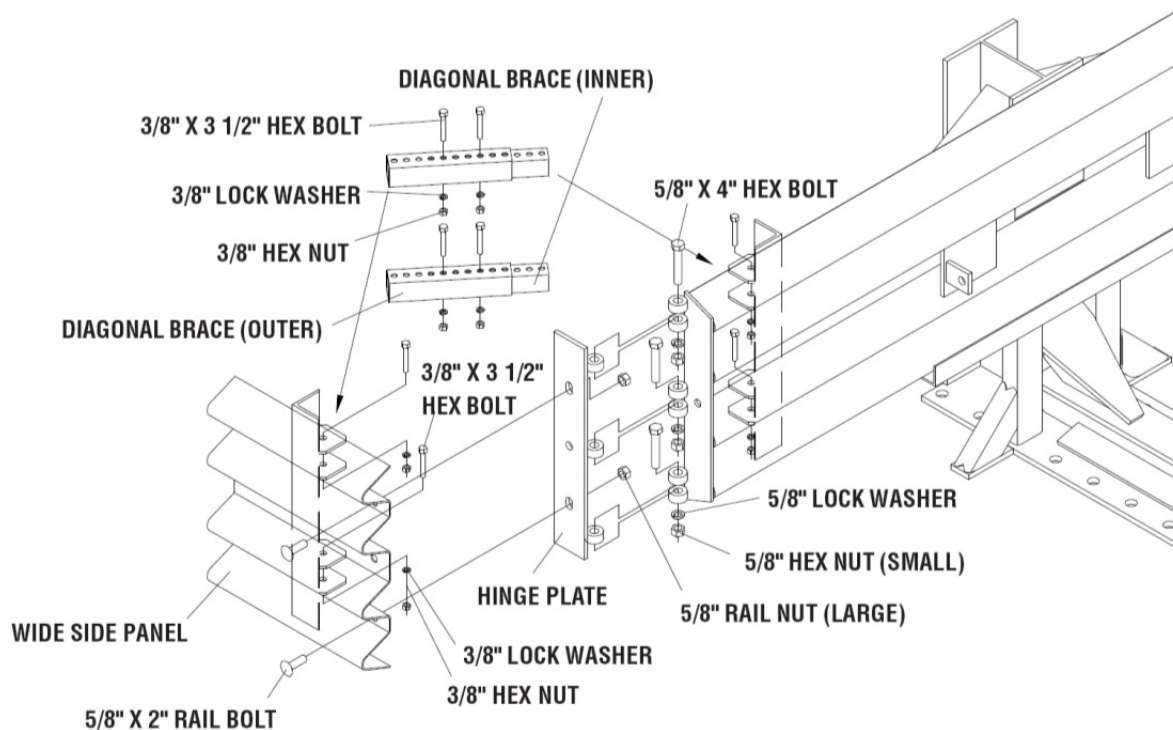


Figure 48
Side Panel/Transition Panel Attachment for Wide Applications

6) Attach Diaphragms

Orient Diaphragms so that the front face of the Quad-beam shape faces toward the Nose of the system as shown in Figure 49. The widest Diaphragm must be assembled closest to the Backup with each subsequent Diaphragm being progressively narrower.

Slide the widest Diaphragm onto the Monorail and all the way to the Backup to ensure system is able to collapse properly during impact. Once this has been verified, slide the Diaphragm forward to approximately 889 mm [35"] in front of the backup. See Figure 50 for the proper location.

Orient and slide all other Diaphragms (except the first three) onto the Monorail and position each as shown in Figure 50. The Diaphragm spacing shown in Figure 50 allows the system to be assembled. Once the system is assembled, the Diaphragms will be moved to their final locations.

Diaphragms 1, 2 and 3 each have bumpers attached to them. Orient Diaphragms 3, 2 and 1 with the bumpers as shown in Figure 50 and the front face of the Quad-Beam shape facing toward the Nose of the system as shown in Figures 49 and 50.

Slide Diaphragms 3, 2 and 1 onto the Monorail and space as shown in Figure 50.

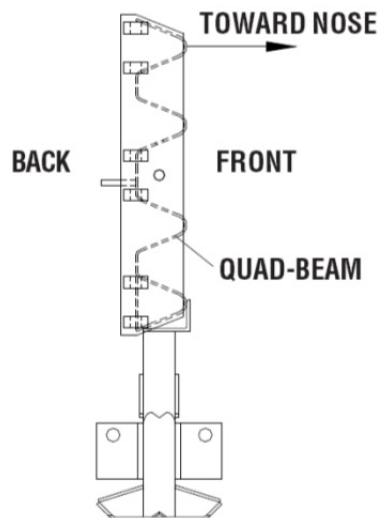


Figure 49
Diaphragm Orientation

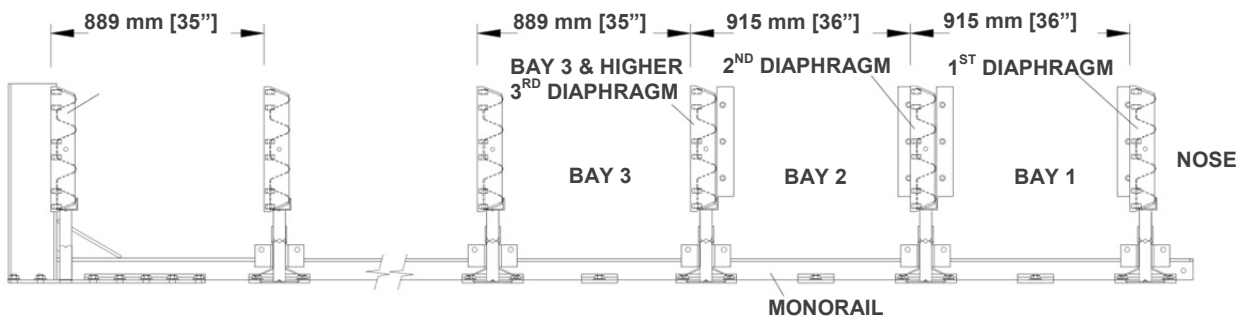


Figure 50
Diaphragm spacing

7) Cylinder Assembly

All QuadGuard® Elite systems utilize a specific Cylinder configuration. Each system may be equipped with up to three different types of Cylinders. See Figure 51 with corresponding Cylinder configuration depending on the number of Bays.

Bays 1 and 2 are always left empty.

Bays 3 through 5 contain a single walled 813 mm [32"] outside diameter Cylinder with QE1 stenciled on the outer surface (see p. 22).

When systems have more than five Bays, the remaining Bays contain double walled 813 mm [32"] outside diameter Cylinders with QE2 stenciled on the outer surface.

The Nose Assembly contains a single walled 711 mm [28"] outside diameter Cylinder with QEN stenciled on the outer surface.



Warning: Placing the wrong type Cylinder in the Nose or any Bay may result in unacceptable crash performance as described in NCHRP Report 350 and this configuration has not been crash tested.

8) Assemble Rear-most Cylinder

Beginning at the Backup, locate and position a Cylinder so it is centered and resting on the Monorail.

Slide the rear-most Diaphragm towards the Cylinder so no gaps exist between the Backup, the Cylinder, and the Diaphragm.

Thread the 1/2" diameter wire rope around the back face of the Backup structure, the Cable Jacketing Tube, and the center of the Cylinder as shown in Figure 51.

Attach ends of the cable using (2) 1/2" Cable Clamps as shown in Figure 51. The Cable Clamps should be separated by approximately 102 mm [4"] as shown.

Take slack out of the cable prior to tightening the Cable Clamps. Draw down the Cable Clamp evenly and torque nuts to 88 N-m [65 ft-lb].

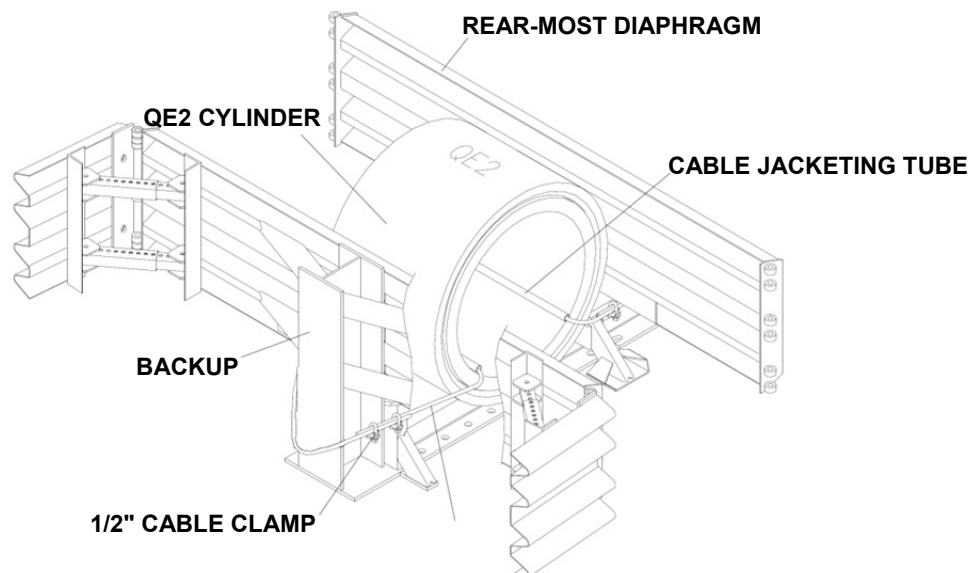


Figure 51
Cylinder Assembly

9) Assemble the Remaining Cylinders

Continue attaching the Cylinders to their common diaphragms using the 1/2" cable, Cable Clamps, and Cable Jacketing Tube (see Figures 52 – 56).

Work forward from the Backup assembling Cylinders as you proceed forward.

Be sure to remove any clearance between the Cylinders and their adjacent Diaphragms prior to removing all possible cable slack before tightening the Cable Clamps.

Except where otherwise noted, the Cable Jacketing Tube should be centered within the length of the Cylinders as shown to prevent the cable from damaging the Cylinders. Figures 53 – 56 illustrate Cylinder configuration at each Diaphragm location.

10) Assemble the QE1 Cylinders

Assemble the QE1 Cylinders in the appropriate Bays towards the front of the system in the same manner used to assemble the QE2 Cylinders.

Again, it is important that all clearance be removed between the QE1 Cylinders and their adjacent Diaphragms before tightening cable.

There is no Cylinder in Bays 1 and 2, therefore, the 1/2" diameter cable just wraps around the legs on the front of the third Diaphragm as shown in Figure 56.

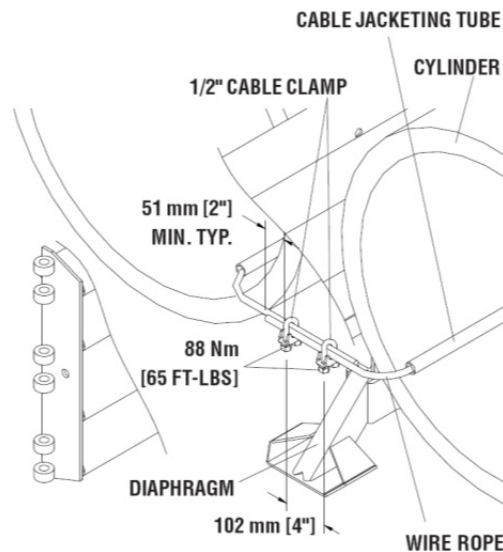


Figure 52

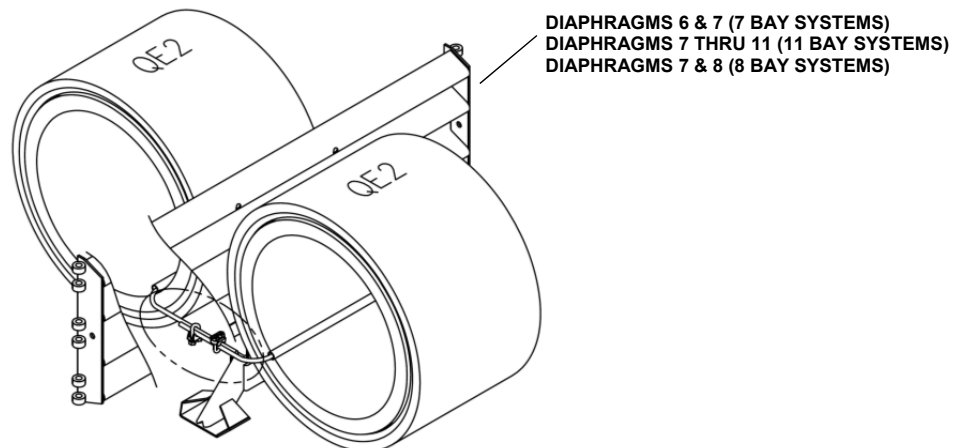


Figure 53

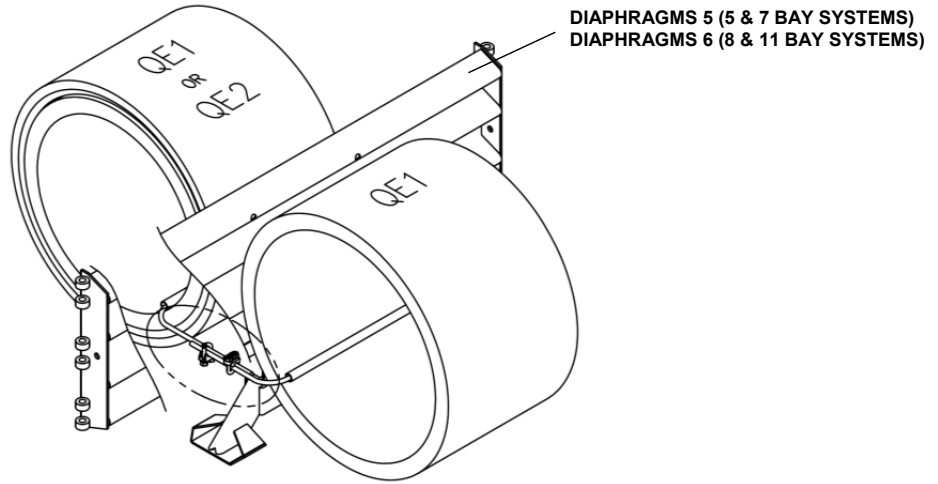


Figure 54

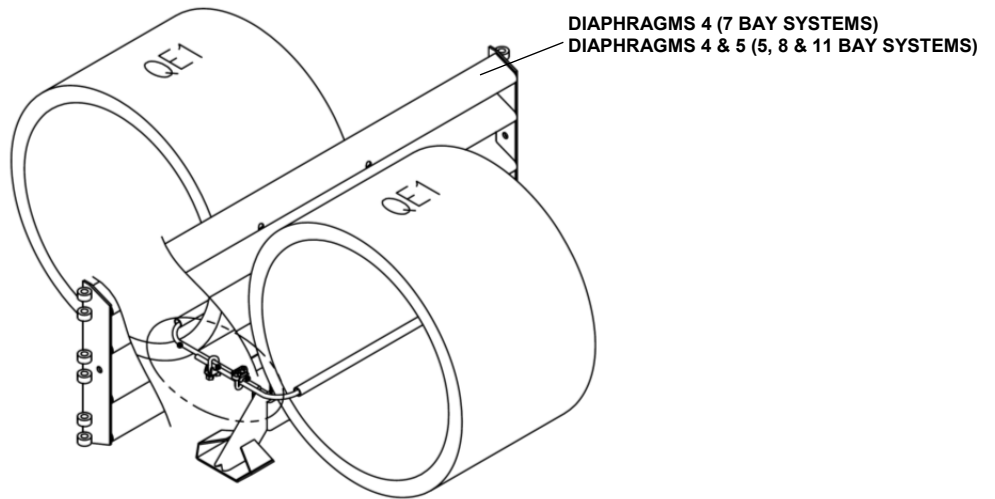


Figure 55

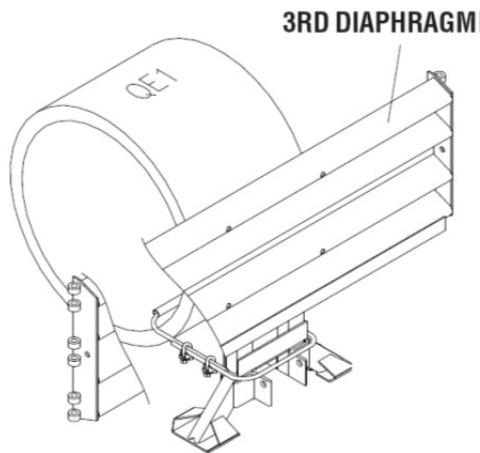


Figure 56
QE1 Cylinder Mounting to 3rd Diaphragm

11) Assemble Indexing Chains

For Bays 3 to the Backup, use (2) Indexing Chains in each Bay. Attach Indexing Chains using 1/2" diameter x 2" long hex head bolts, nuts, and washers as shown in Figure 57.

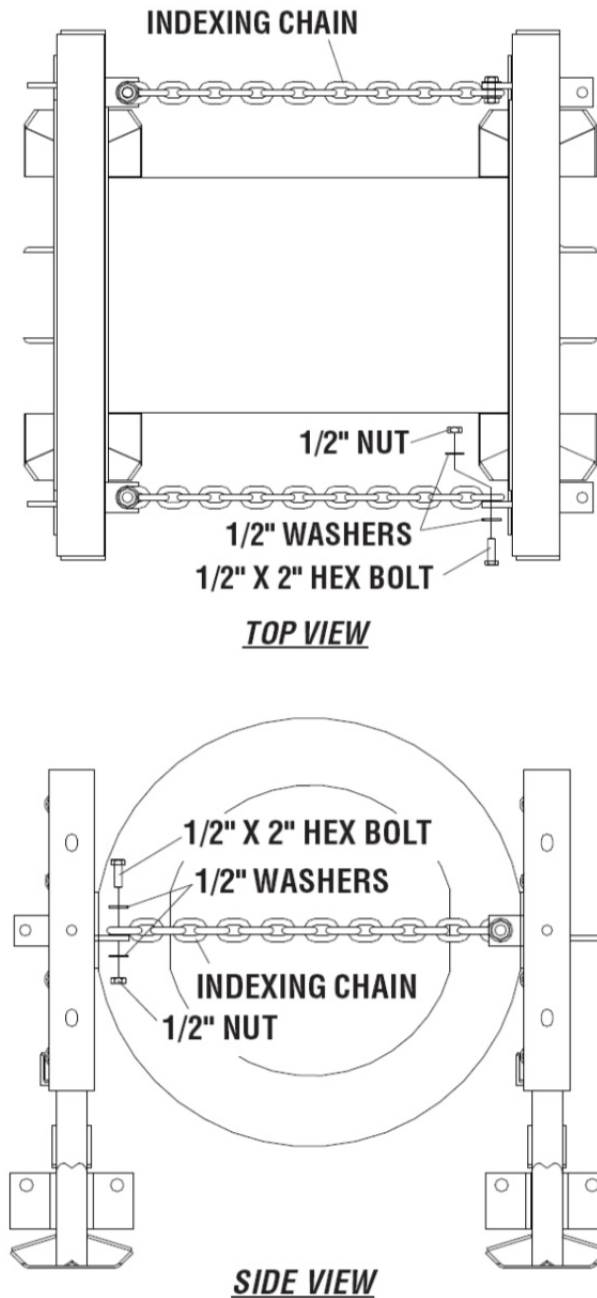


Figure 57
Attach Indexing Chains
(Fender panels not shown for clarity)

12) Attach End Cap

Using 5/8" x 3 1/2" G5 hex bolt, 5/8" hex nut, and 5/8" lock washer, attach the end cap to the front of the first Monorail segment (see Figure 58).

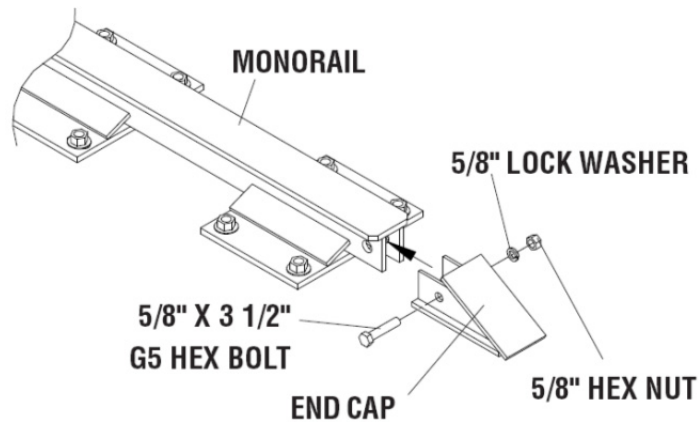


Figure 58
End Cap Attachment

13) Attach Fender Panel

Note: Hinge plates may be factory assembled to Diaphragms. If not, use 5/8" x 4" hex bolts, lock washers, and nuts as hinge pins to attach Hinge Plates to Diaphragm.

Starting at the last Bay, attach left and right Fender Panels as shown in Figure 60. Attach the hinge plate at the front of the Fender Panels to the Diaphragm in front using (3) 5/8" x 4" hex bolts, 5/8" hex nuts, and 5/8" lock washers.

Attach Mushroom Washer Assembly as shown in Figures 60 and 61 but do not torque at this time.

Be sure Mushroom Washer lays flat against the Fender Panel as shown in Figure 62. Standoff on washer must be seated completely through slot.

Note: Do not mix the 5/8" rail nuts (large) with the 5/8" hex nuts (small). The rail nuts are oversized.

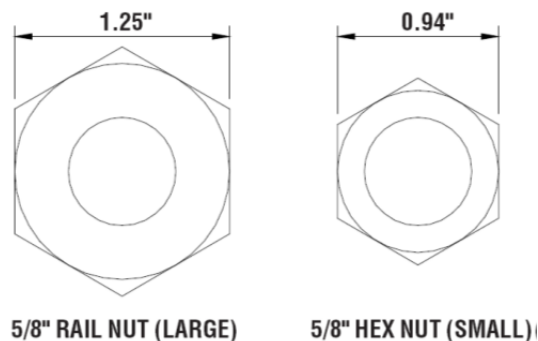


Figure 59
Rail Nuts are Oversized

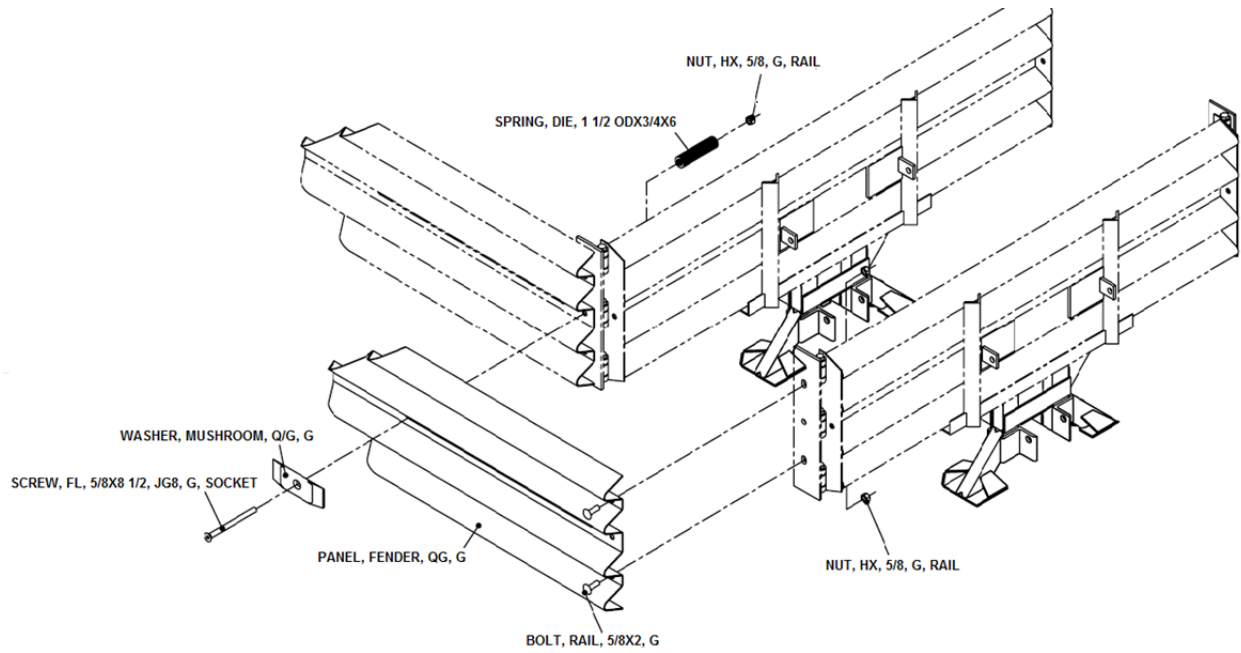


Figure 60
Fender Panel Assembly

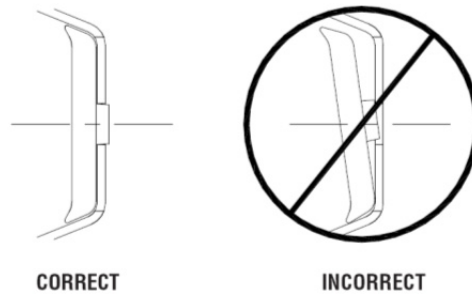


Figure 61
Mushroom Washer Orientation

14) Attach Pullout Brackets

Using 5/8" X 2 1/4" G8 hex bolts, 5/8" x 1 3/4" flat washers, and 5/8" hex nuts, attach Pullout Brackets to 1st Diaphragm as shown in Figure 62.

Be sure Mushroom Washer lays flat against the Fender Panel as shown in Figure 61. Standoff on washer must be seated completely through slot.

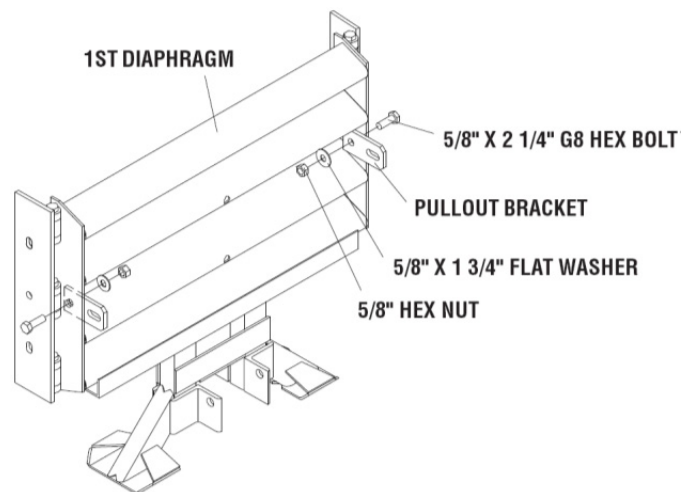


Figure 62
Pullout Bracket Attachment

Revision F August 2014
All rights in copyright reserved

15) Attach Nose Assembly

Attach the Nose Cylinder using (2) 1/2" x 5 3/4" long threaded rods through the Nose Cylinder Plate, Nose Cylinder, and Diaphragm (see Figure 63). Secure each 1/2" threaded rod with flat washers, nuts, and a Nose Clamp Shim and torque to 27 N-m [20 ft-lb] minimum to 80 N-m [60 ft-lb] maximum.



Warning: Placing the wrong type Cylinder in the Nose or any Bay **will** result in unacceptable crash performance as described in NCHRP Report 350.

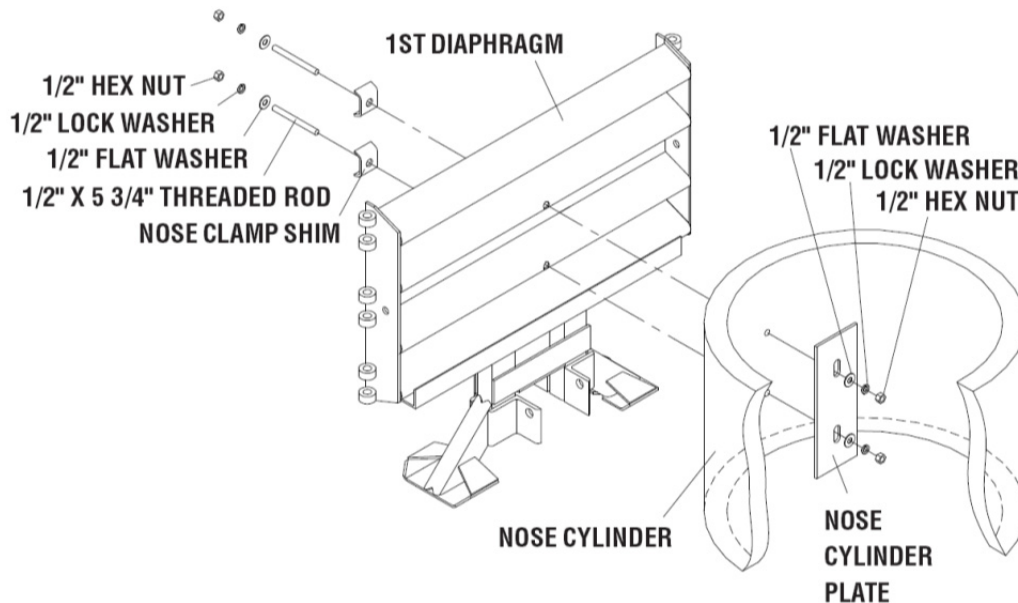


Figure 63
Attach Nose Cylinder to First Diaphragm

A) Belt Nose Assembly:

- Using 5/8" x 5" hex bolts, 5/8" x 1 3/4" flat washers, and 5/8" hex nuts, attach hinge plate to Fender Panel as shown in Figure 65 (three places per side).
- Thread second 5/8" nuts onto the assembled bolts. Be sure the faces of the nuts are flush with humps on Fender Panels (see Figure 65). Slide second 5/8" x 1 3/4" flat washers onto bolts (three places per side).
- Align holes in each end of the Nose Belt with the assembled bolts (three per side) and slide Nose Belt onto bolts.
- Align holes in Belt Clamps with bolts and slide Belt Clamps onto bolts.
- Using third 5/8" x 1 3/4" flat washers and third 5/8" hex nuts, secure the Belt Clamps and Nose Belt (three places per side).
- Be sure Fender Panel assembly is bolted to Diaphragm at the hinge plate with 5/8" x 5" hex bolts, 5/8" nuts, and 5/8" flat washers in 3 places on each side.

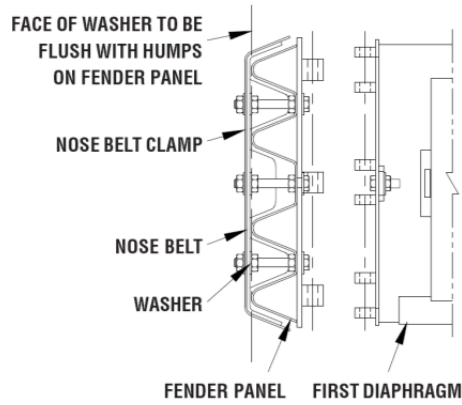


Figure 64

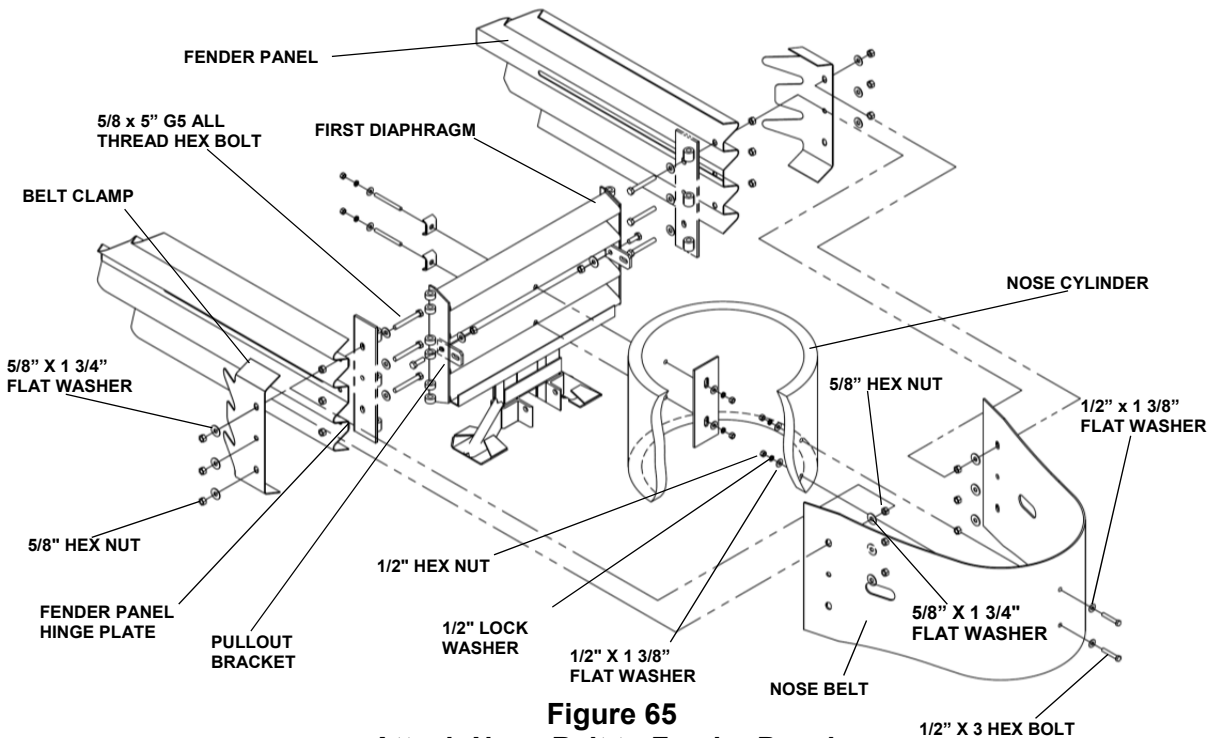


Figure 65

Attach Nose Belt to Fender Panels

Note: The Nose of the system may be delineated to comply with local codes (inverted chevron, reflectorized sign, etc.).

16) Diaphragm Spacing

Attach 10 mm [3/8"] grade 40 x 6 m [20'] chain to Pullout Brackets on Diaphragm No. 1 (see Figure 66). Attach both ends of chain to a heavy vehicle (such as a 1 ton pickup truck).

Pull the QuadGuard® Elite forward slowly until the system is fully extended, chains are taut, and Mushroom Bolts are bottomed out in slots in Diaphragms without chains.

Torque all Mushroom Washer Assembly nuts until they bottom out on threads of screws. Remove chains from Pullout Brackets.



Warning: Stand clear in case chain breaks or becomes disconnected.

Note: Do not wrap a chain around the bottom legs of the front Diaphragm and pull. This may cause binding of the system. The pull force should be aligned with the long slots in the Fender Panels to prevent system binding.

17) Assemble Hit Indicator to Diaphragm No. 1

The Hit Indicator should be the last component attached to the system. Bolt the Hit Indicator to the first Diaphragm with the hardware provided as shown in Figure 66.

Rotate the Hit Indicator to its horizontal position and lock it into position by bending the Trigger Clip around the second Diaphragm as shown in Figure 67.

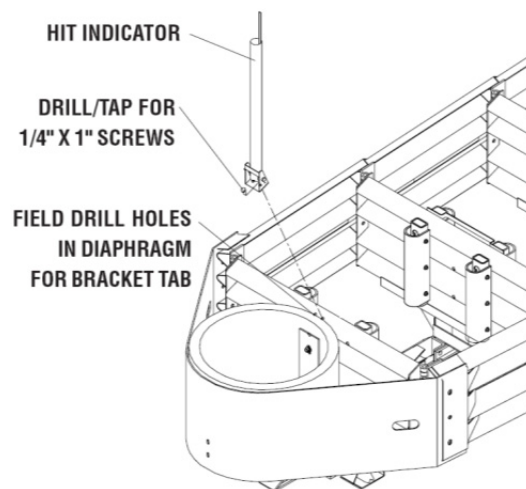


Figure 66
Attach Hit Indicator



Important:

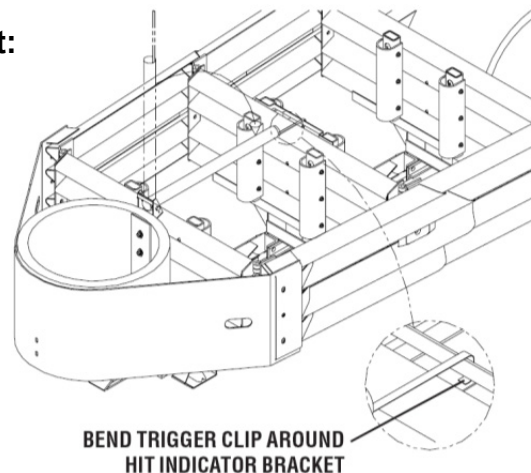


Figure 67
Rotate Hit Indicator/Bend Trigger Clip

18) Checking the System Assembly

Check to ensure that all fasteners are properly tightened throughout the system at this point (anchor bolts, etc.). Check all Fender Panels (see Table C). If they do not fit tightly against the underlying panel, system realignment may be necessary (see Figure 68).



Warning:

Table C

Mushroom Bolt Assemblies	Torqued to 80 N-m [60 ft-lb]
Anchor Studs	Torqued to 165 N-m [120 ft-lb] May slightly protrude above nuts see Figure 45 on p. 39
All Other Bolts	Tightened
Fender Panel Wide Systems See below	Maximum Gap Allowed 25 mm [1.00"] see Figure 68

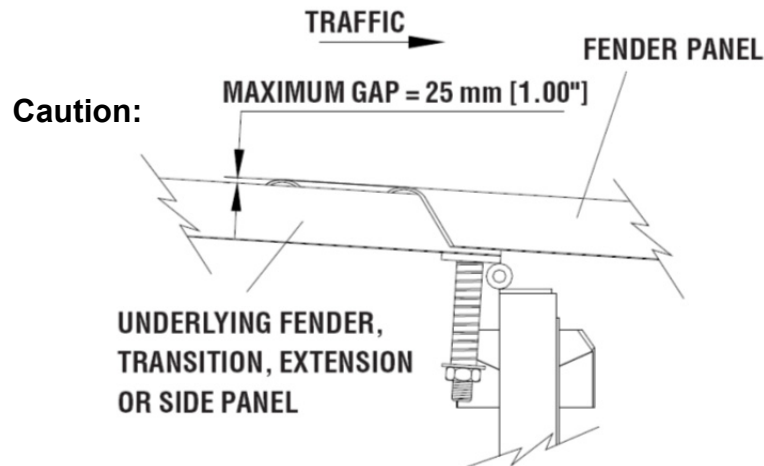


Figure 68

Maximum Fender Panel Gap on Bidirectional Traffic Side of System

MP-3[®] Polyester Anchoring System

The MP-3[®] Polyester Anchoring System is a quick and easy way to securely anchor crash cushions and other common highway devices. MP-3[®] features high pullout strength, superior vibration resistance, and exceptional durability.

Each MP-3[®] kit contains a can of MP-3[®] resin, hardener, cold weather promoter, studs, washers, and a complete safety sheet. The cold weather promoter shortens hardening time by as much as seven hours. Both vertical and horizontal assemblies are possible using the MP-3[®] system.

Vertical Assemblies

Note: Read MP-3[®] Instructions before starting.

1) Prepare the Concrete Pad



Warning: Do not allow the MP-3[®] resin or hardener to contact skin or eyes. See material safety data sheet supplied with the MP-3[®] kit for first-aid procedures. Use only in well-ventilated area. Do not use near open flame.



Warning: Wear safety goggles and gloves during application process.

The Anchor Bolts (studs) that anchor the QuadGuard Elite system Backup and/or Monorail sections to the concrete pad must be those shipped in the kit or of high strength steel (830 MPa [120,000 psi] minimum tensile strength or equal). These studs must be set in minimum 28 MPa [4000 psi] concrete. Allow the concrete to cure a minimum of seven days before applying MP-3[®].

2) Drill Holes

Note: Trinity Highway recommends using (2) double fluted drill bits to achieve optimum tensile strength when assembling the MP-3[®] anchoring system.

Use the part that is to be anchored as a drilling template. Drill the holes 3 mm [1/8"] larger than the stud diameter to the recommended depth, using a rotary hammer drill. If a diamond drill bit is used, the surface will be too smooth for the MP-3[®] to adhere and full strength will not be achieved. Refer to the MP-3[®] assembly instructions provided with your kit. Check to be sure all the holes are drilled to the proper depth and aligned with the part to be anchored. Please refer to Table D.

Table D
MP-3[®] Anchoring Information

Stud Size:	Concrete Bit Size	Minimum Depth	Recommended Torque
3/4"x 6 1/2"	22 mm [7/8"]	125 mm [5"]	165 N-m [120 ft-lb]
3/4"x 7"	22 mm [7/8"]	140 mm [5" 1/2"]	165 N-m [120 ft-lb]
3/4"x 18"	22 mm [7/8"]	420 mm [16 1/2"]	<15 N-m [<10 ft-lb]

3) Clean the Holes

Blow the concrete dust from the hole using oil-free compressed air. Thoroughly brush it with a stiff-bristled brush and then blow it out again. If the hole is wet, completely flush it with water while brushing. Then blow it clean using oil-free compressed air.

4) Mix the Resin and Hardener

Wear gloves, apron, and safety goggles when opening MP-3[®] Part A-resin and Part B-hardener containers. Pour Part B into Part A, and mix vigorously for 30 seconds to form MP-3[®] grout (an anchor stud may serve as a stirring rod).

5) Add Cold Weather Promoter (in Cold Weather)

For faster hardening in cold weather, promoter may be used. Add the entire contents of the partially filled promoter container to the MP-3[®] grout, then mix for an additional 30 seconds. Use immediately because the MP-3[®] grout will thicken quickly. Refer to Table E for hardening times.



Warning: Do not use promoter when the temperature is above 15 degrees Celsius (60 degrees Fahrenheit). Grout will harden too quickly. Use only in well-ventilated area. Do not use near open flame.

6) Pour Grout into Holes

Crimp the mouth of the can to form a spout, and pour the MP-3[®] grout mixture down into the hole through the part. Fill the hole to 1/3 - 1/2 full.



Caution: Do not overfill or under fill the hole. If the hole is overfilled, there will not be enough grout for all of the anchor studs/kit. If hole is under filled the grout may not develop the required pull out strength.

7) Add the Washers and Nuts

Place a flat washer onto the stud, then thread a nut on until 1 or 2 threads of the NUT are left exposed.

8) Insert Studs in Holes and Wait for Grout to Harden

Push the stud down through the part to be anchored and into the hole. Give the stud several twists in the MP-3[®] to wet the threads.



Caution: Do not disturb or load the stud until the MP-3[®] material has hardened (see Table E).

9) Torque the Nuts

Once the grout has hardened, torque the nut to the recommended values (see Table D).

Table E
Approximate Hardening Times (hours)

Temperature		Hardening Times (hours)	
C°	F°	No Promoter	With Promoter
>26	>80	1/2	N/R*
22-26	70-79	1	N/R
16-21	60-69	2	N/R
10-15	50-59	4	3/4
4-9	40-49	8	1
-1-3	30-39	N/R	1 1/2
<-1	<30	N/R	N/R**
*Not recommended			
**Contact Customer Service Department for more information			

Horizontal Assemblies

The horizontal MP-3[®] kit is the same as the vertical kit except that a dispenser cartridge for a standard caulking gun is supplied in the horizontal kits and the resin is a thixotropic (TX) resin. The TX-Resin is a gelled resin designed to keep the grout in place in horizontal holes during application.

When using the horizontal MP-3[®] kits, follow the vertical instructions with the following exceptions:

1) Thread Dispensing Tip onto Dispenser

Prior to mixing the grout, carefully thread the dispensing tip onto the cartridge.

2) Pour Mixed Grout into Cartridge

Once the grout is mixed, crimp the mouth of the can to form a spout and pour the MP-3[®] grout into the open end of the cartridge (use mixing stud to scrape out the portion remaining in the can). You may use the box to hold the cartridge upright. Close the box lid and poke the cartridge tip into the top of it. Seal the cartridge with the plunger provided.

3) Place Cartridge in Caulking Gun and Dispense Grout

Cut off the small end of the cartridge tip. Place the cartridge into caulking gun and dispense until MP-3[®] TX grout reaches the tip of the cartridge, then release pressure. Push the cartridge tip through the part to the bottom of the hole and dispense while slowly withdrawing the tip.



Caution: Do not overfill or under fill the hole. Fill hole approximately 1/3 to 1/2 full. If the hole is overfilled, there will not be enough grout for all of the anchor studs/kit. If hole is under filled the grout may not develop the required pull out strength.

4) Add the Washers and Nuts

Put washer and nut on stud, leaving nut flush with end of stud.

5) Insert Studs into Holes

Push stud through part to be anchored and into hole.

Note: In horizontal applications, the stud should be flush with the top of the nut and torqued to 165 N-m [120 ft-lb].

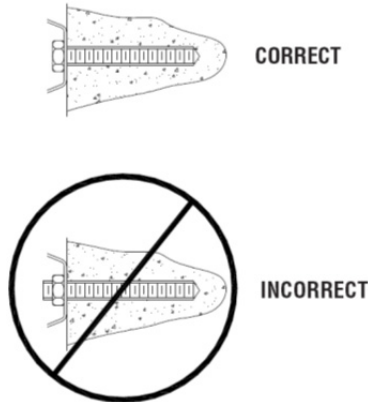


Figure 69
MP-3[®] Horizontal Application

MP-3[®] Assembly Cautions

1) Shelf life

If the shelf life of the MP-3[®] has expired (see MP-3[®] kit for expiration information), mix a small amount of MP-3[®] in the proportions of one part A to two parts B by volume. If the material does not set according to the instructions, contact Trinity Highway for guidance.



Warning: Do not use MP-3[®] if: the material fails to set up, Part A-Resin had gelled (for vertical applications), or TX-Resin is NOT gelled (for horizontal applications).

2) Steel rebar

If steel rebar is encountered while drilling an MP-3[®] anchor bolt hole, apply one of the following solutions:

- A) Using a diamond core drill or rebar drilling tool, drill through the rebar only and then switch back to the concrete bit to drill into the underlying concrete until the proper hole depth is reached.



Caution: Do not drill through rebar without first obtaining permission to do so from the local project engineer.

- B) Drill a new hole down at an angle past the rebar to the proper depth. Anchor the stud by completely filling both holes with MP-3[®].

Maintenance

Frequency

Inspections are recommended, as needed, based upon volume of traffic and impact history. Visual Drive-By Inspections are recommended at least once a month. Walk-Up Inspections are recommended at least once a year.

Visual Drive-By Inspection

- 1) Encountering a system with the Hit Indicator in the vertical position mandates inspection of the system. A walk-up inspection will be necessary.
- 2) Inspect the system in accordance with the QuadGuard® Elite Maintenance Flow Chart on page 65.



Caution: It is important to inspect a system after it has been impacted even if it appears to be self-restored and fully maintained. In particular, check the Fender Panels/Diaphragm attachment bolts to be sure none have failed. Again, only the local highway authority can determine if the system is reusable after impact.

Note: Refer to Cylinder placement on pages 63 and 64.

- 3) Be sure the Nose Cover is in place.
- 4) Note the location and condition of the QuadGuard® Elite and the date of visual drive-by inspection.

Walk-Up Inspection



Caution: A system that has been impacted can store energy in collapsed Cylinders and may spring back unexpectedly causing possible serious injury (see “Restoring Collapsed Systems” on page 61). Use caution when inspecting, disassembling or restoring systems that are collapsed in any amount.

Maintenance Checklist

- 1) Clear and dispose of any debris on the site.
- 2) Be sure all bolts are tight and rust free.
- 3) Be sure Concrete Anchor Bolts are securely anchored.
- 4) Be sure Diaphragm Legs are straight and chains are taut.
- 5) Be sure all Mushroom Washer Assemblies are properly aligned and positioned (see Figure 71).
- 6) Fender Panels and Transition Panels should nest tightly against the system. For wrong way traffic, the maximum gap allowed is 20 mm [.78”] (see Figure 73).
- 7) Be sure Cylinders are in good condition and are properly positioned on their Support Brackets.
- 8) Inspection of the system is necessary if the Hit Indicator is in the UP position, even if system appears normal.

Note: The energy-absorbing plastic Cylinders lose their ability to absorb energy with increasing number of system impacts. After multiple full capacity design impacts, the system will no longer be able to meet the requirements as specified in NCHRP Report 350. To ensure that Cylinder replacement is accomplished before this condition occurs, it is essential that this part of the inspection be conducted every time the Hit Indicator indicates the system has been impacted. It is the sole discretion of the local highway authority that has specified the use of this system as to whether the system or any part thereof can continue in use.

The rear-most Cylinder must measure at least 660 mm [26"] for proper impact performance (see Figure 70). If distance is less than 660 mm [26"], replace all QE1, QE2 and QEN Cylinders. If distance is greater than 660 mm [26"], inspect all Cylinders for major cracks, tears or cuts. Replace any damaged Cylinders. Please call Trinity Highway Customer Service Department if you have any questions.

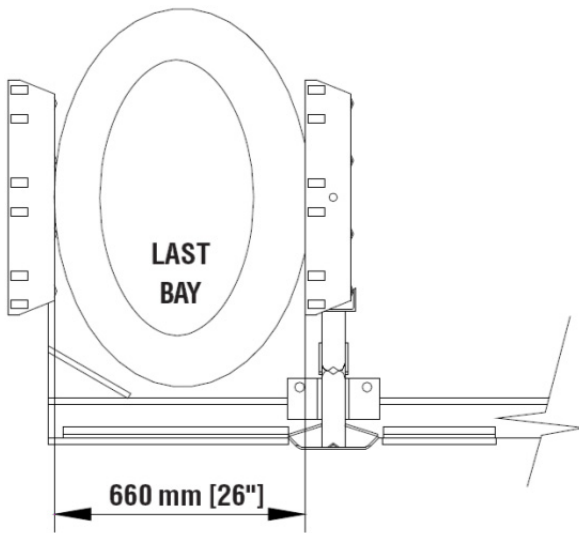


Figure 70

Distance Across Minor Axis of QE2 Cylinder

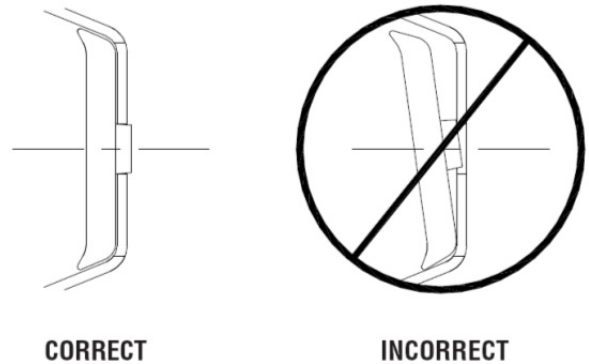


Figure 71

Mushroom Washer Orientation

Note: Refer to Cylinder placement on pages 63 and 64.

- 9) Be sure system is at its full length.



Caution: Systems that are not restored to their full length **will not** perform to impact performance standards of NCHRP Report 350.

- 10) Make all necessary repairs as described above (see p. 58 for Post-Impact Instructions).
- 11) Note the location and condition of the QuadGuard® Elite, and any work done, in the Impact Attenuator Inspection Logbook under the date of this inspection. If further repair is required, note repair request date in logbook. Walk-up inspections are recommended, as needed, based upon volume of traffic and impact history. Refer to Post-Impact Instructions beginning on page 58 for more information.

Post-Impact Instructions

- 1) Deploy the appropriate traffic-control devices to protect your crew. Follow the local codes and traffic control plan as set forth by the local highway authority.



Warning: A system that has been impacted can store energy in collapsed Cylinders and **may spring back unexpectedly** causing possible serious injury. Use caution when disassembling and refurbishing damaged units.

- 2) Check to see that all Anchor Bolts have remained firmly anchored to the roadway surface. Replace any that are loose, broken, or pulled out. Proper performance of the system depends on the Monorail Anchors being properly deployed.
- 3) Clear and dispose of any debris on the site.
- 4) Check the system to be certain that the Mushroom Washer Assemblies holding the Fender Panels together are still intact and that the system has not been deformed in a way that would prevent pulling it back to its original position.
- 5) Be sure that the Diaphragm Support Legs are all properly attached to the Monorail.
- 6) Attach 10 mm [3/8"] x 6 m [20'] Grade 40 (minimum) chain to Pullout Brackets on first Diaphragm (see Figure 72). Attach both ends of chain to a heavy vehicle (such as a 1 ton pickup).



Warning: Stand clear when pulling system out in case chain breaks or becomes disconnected.

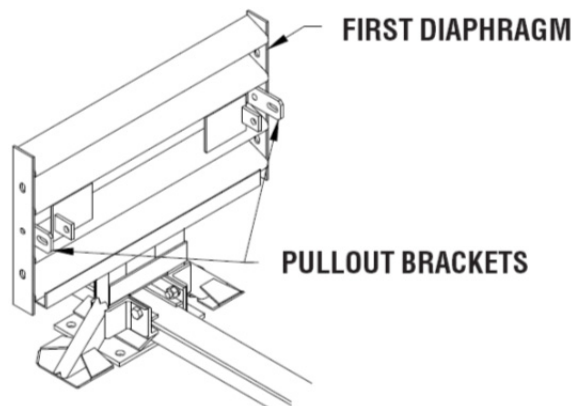


Figure 72
Attach Chain to Pullout Brackets

Note: Do not wrap a chain around the bottom legs of the front Diaphragm and pull. This may cause binding of the system. The pull force should be aligned with the long slots in the Fender Panels to prevent system binding.



Important: Slowly pull the QuadGuard® Elite forward until the system reaches its original length. Have someone watch the system during repositioning to be certain previously undetected damage does not cause the Diaphragms to bind or pull out improperly.

- 7) Remove all damaged Cylinders from within the system. Inspect the system in accordance with the QuadGuard® Elite Maintenance Flow chart on page 65. After typical design speed impacts, the Cylinders are potentially reusable: See Limitations and Warnings on page 6.
- 8) Check to see that the Diaphragms are in usable condition. Diaphragms that are bowed or have bent legs must be replaced.
- 9) Check that the Fender Panels are properly attached with the Mushroom Washer Assemblies. Check all bolt connections of Fender Panels to Diaphragms. Damaged bolts, Fender Panels, and Transition Panels must be replaced.
- 10) Check the gap of the Fender Panels. The maximum gap allowed for these overlapping parts on the side of the system with traffic approaching from the rear (including Fender Panels overlapping components behind the system) is 20 mm [.78"] for narrow systems and 25 mm [1.00"] for wide systems (see Figure 73). Be sure the Mushroom Washer Assemblies are torqued to 80 N-m [60 ft-lb]. If the gaps between the Fender Panels are still too large, it may be necessary to replace bent parts.
- 11) Replace all damaged Cylinders. Inspect the system in accordance with the QuadGuard® Elite Maintenance Flow Chart on page 65. If a Cylinder's condition is questionable, a photo of the Cylinder may be forwarded to Trinity Highway for evaluation.
- 12) Check the torque of all fasteners on the system (see Table F on p. 60).
- 13) Check that the site is free from any debris. The QuadGuard® Elite is once again ready for use.



Caution:

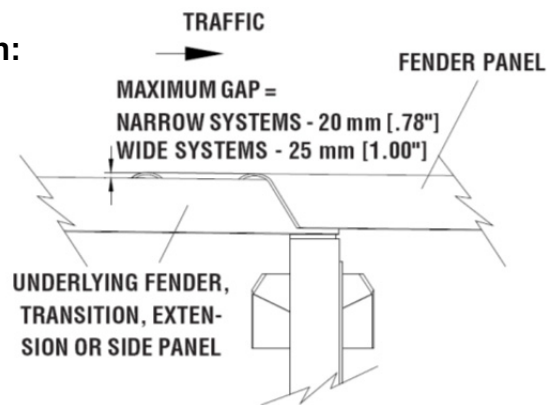


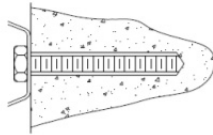
Figure 73
Fender Panel Gap

Table F Torque Specifications

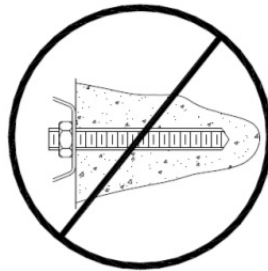


Warning:

Mushroom Bolt Assemblies	Torqued to 80 N-m [60 ft-lb]
Anchor Studs	Torqued to 165 N-m [120 ft-lb] May slightly protrude Above Nuts (see Figure 74).
All Other Bolts	Tightened



CORRECT



INCORRECT

**Figure 74
MP-3[®] Horizontal Assembly**



Warning: Self-restoring systems, such as the QuadGuard[®] Elite, have the ability to “store” spring-back energy that could potentially cause sudden movement of these systems and potential injury to unsuspecting workers. After impacts that exceed the NCHRP Report 350 criteria, these systems may suffer damage and bind up. This condition would be visually evident by Bays of the system staying collapsed after an impact (with Bay-spacing of 24” or less for the QuadGuard[®] Elite). Extreme compression of QuadGuard[®] Elite cylinders after an impact, especially the thick-walled cylinder (QE2), is an indication that the system is storing large amounts of “spring-back” energy that could potentially cause sudden movement of the system and potential injury to an unsuspecting person. Repair of QuadGuard[®] Elite in this condition must be done with caution.



Warning: A compressed and locked up system may store large amounts of potential energy in the Cylinders. DO NOT stand in front of, on top of, or put any member of your body on or inside any portion of a collapsed system. Instead, use a chain and truck to pull from the front of the system, as explained in the next section.

Restoring Collapsed System

1) System Restoration

Before starting this procedure, please read and understand the foregoing “**Warning**” statement. The following instructions outline a set of steps for positioning a large vehicle up against a compressed system to prevent unexpected system spring-back while maintenance workers are attempting to repair the system.

- A) Position a truck of not less than 6000 kg [13,000 lbs.] centered on the system just in front of the Nose Assembly. The truck should be presenting its strongest bumper to the system. The selected bumper’s height should be such that the center of the bumper rests on the middle of the system’s Nose Assembly (approximately, 610 mm [24”] in height).
- B) Drive the truck so that the bumper displaces the systems Nose Cylinder approximately 150 mm [6”]. In the absence of the Nose Assembly, place a protective material between the bumper and the leading Diaphragm leaving approximately 25 mm [1”] gap between the protective material and the vehicle’s bumper. The driver should remain in the vehicle depressing the brake pedal after the vehicle has been placed in position.



Warning: Once the leading bumper is over the system’s Monorail, the vehicle may be subject to impact by the system due to an unexpected restoration. The driver should be wearing a seat belt and have the vehicle in the lowest possible gear when approaching the system. In the event that the system unexpectedly deploys before Step B is completed, the driver should apply the brakes immediately, bringing the vehicle to a controlled stop. The driver should then put the vehicle in neutral while still applying the brakes. Gradually release the brakes, allowing the system to push the vehicle back in a safe and controlled manner.

- C) It should now be safe for a maintenance worker to inspect the system to determine where mechanical binding is present. Remove all debris from the system prior to checking for binding. The binding will probably be located at the monorail guides on the forward-most Diaphragm(s) or Fender Panels. Cautiously using a pry bar or jostling the system with a vehicle may aid in releasing the mechanism of binding. Once released, the driver should allow the system to extend in a safe and controlled manner.



Warning: Use caution when releasing the mechanism of binding. Keep hands and other body parts as far away as practically possible from the system. Be careful of tools (pry bar, etc.) that may move unexpectedly by the system if binding is released.

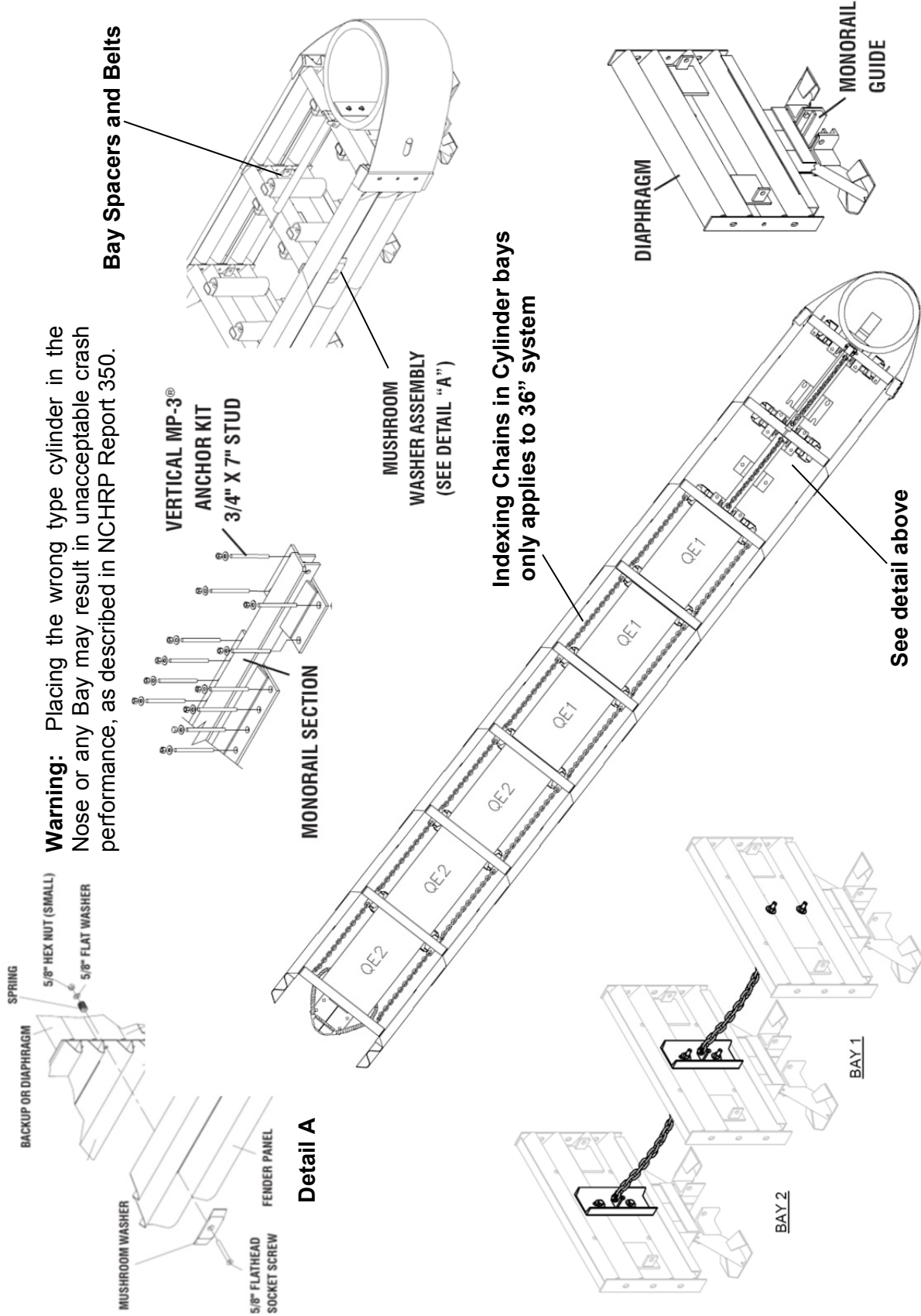
- D) Replace all damaged system components and reassemble per the QuadGuard Elite Manual Assembly instructions.

Parts Ordering Procedure

Make a list of all damaged parts using part descriptions shown on pages 63 and 64. Answer the following questions in the spaces provided. This information is necessary to receive the proper parts.

Table G
QuadGuard® Elite Ordering Information Chart

Description:	Choices	Fill in this section
What type of Transition Panel? Be sure to note right side, left side, or no Transition (see p. 14).	Quad to W Quad to Thrie Quad to End Shoe Quad to Safety Shape Barrier	
Width of Backup	100 mm [4"] Offset Panel 610 mm [24"] 760 mm [30"] 915 mm [36"] 1620 mm [64"] 2100 mm [83"] Other	



Detail of indexing chains for 24", 30" and 36" system

Figure 75

Warning: Placing the wrong type cylinder in the Nose or any Bay may result in unacceptable crash performance, as described in NCHRP Report 350.

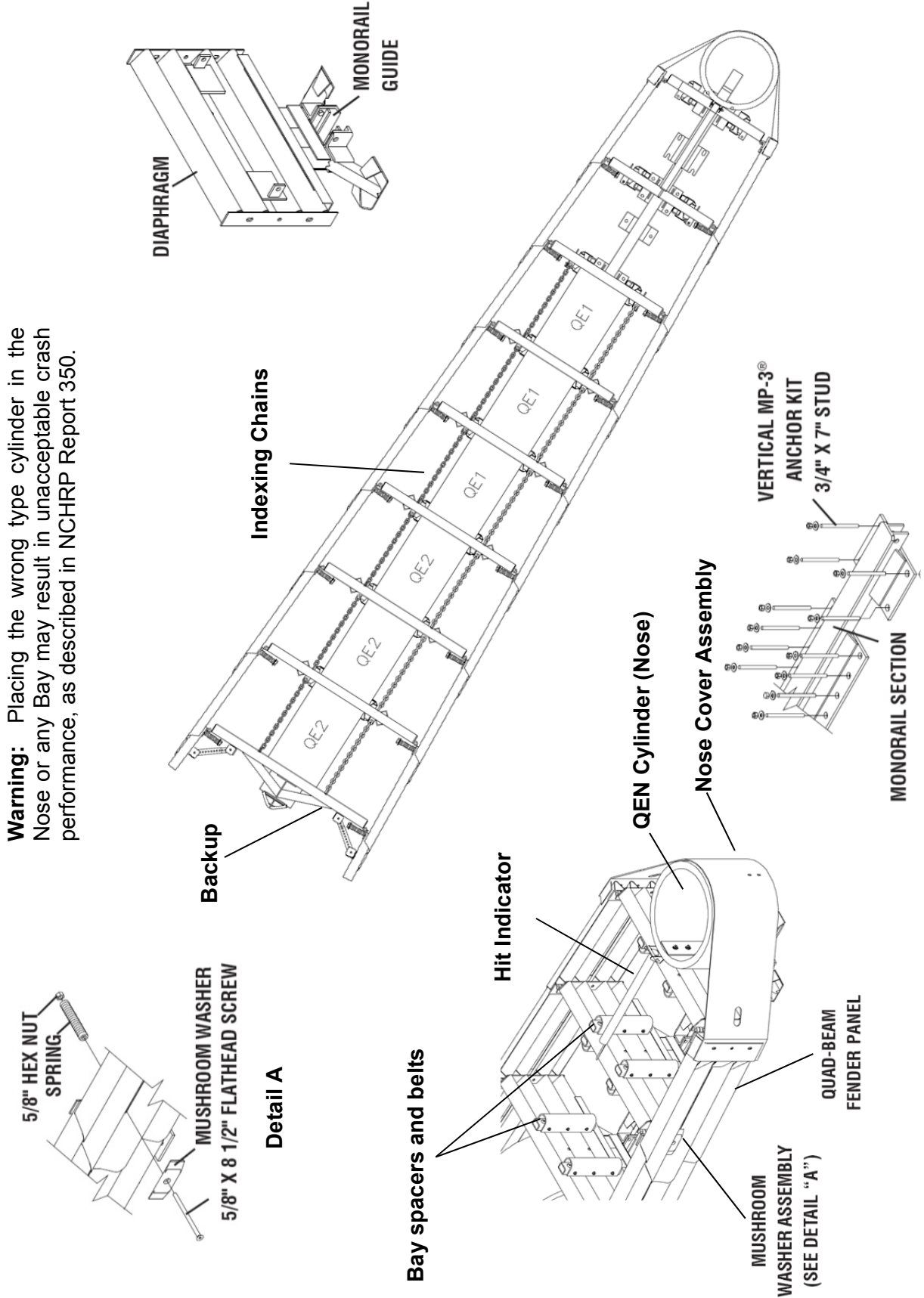
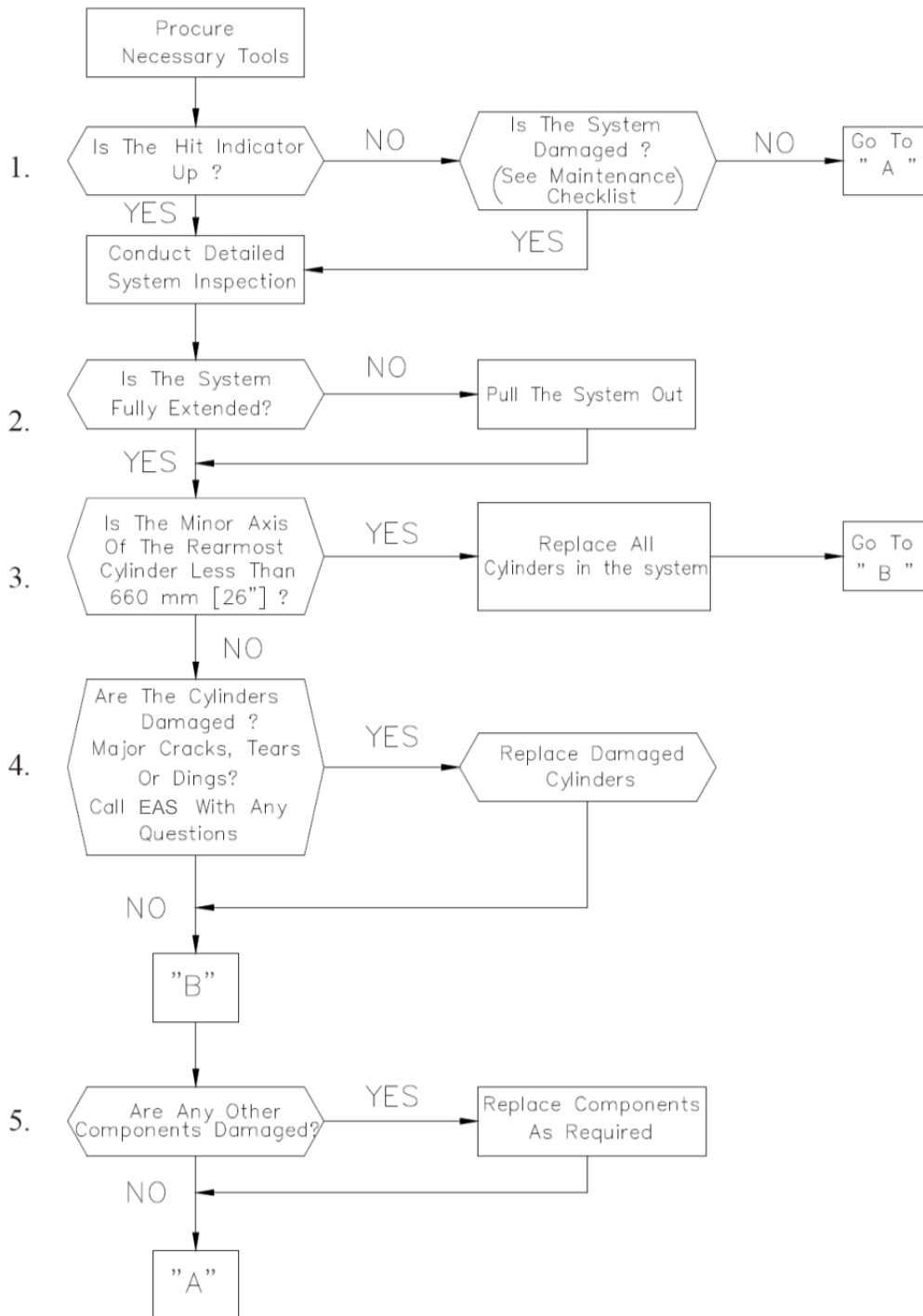


Figure 76

Maintenance Flow Chart

This flow chart is provided only to clarify the sequence of steps. Refer to the appropriate sections of this manual for any procedures that need to be performed.



QuadGuard® Elite Maintenance Flow Chart

Notes:



TRINITY

HIGHWAY

Ahead of the Curve™

For more complete information on Trinity Highway products and services, visit us on the web at www.trinityhighway.com. Materials and specifications are subject to change without notice. Please contact Trinity Highway to confirm that you are referring to the most current instructions.

www.trinityhighway.com

888.323.6374 (USA)

+1 214.589.8140 (International)