

NOTE:  
INSTALL RAIL PARALLEL TO ROADWAY EDGE LINE.  
WHEN TAPER IS REQUIRED BY DESIGN ENGINEER,  
A 25 TO 1 TAPER OVER THE LENGTH OF SYSTEM IS  
ALLOWABLE.

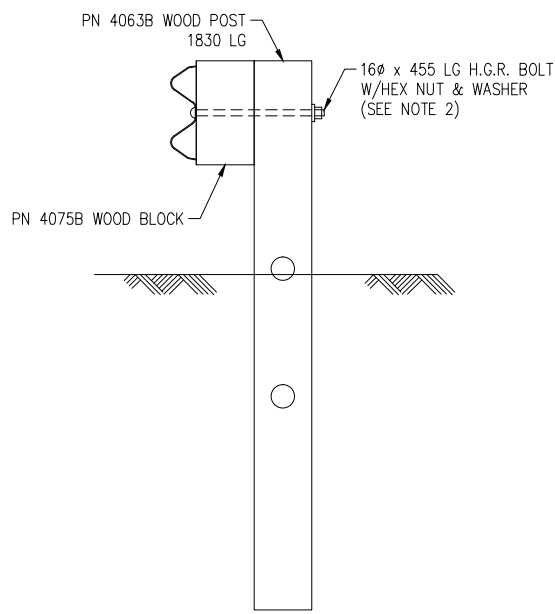

SECTION "C-C"  
(TYP @ POSTS #3 THRU 8)

METRIC MEASUREMENTS NOTE:  
1. ALL DIMENSION SHOWN ARE IN mm UNLESS NOTED  
2. ALL HARDWARE, WOOD PRODUCTS AND OTHER FABRICATED MATERIAL  
USED IN THIS SYSTEM WILL BE CONVERTED TO NEAREST AVAILABLE  
ENGLISH MEASUREMENTS.

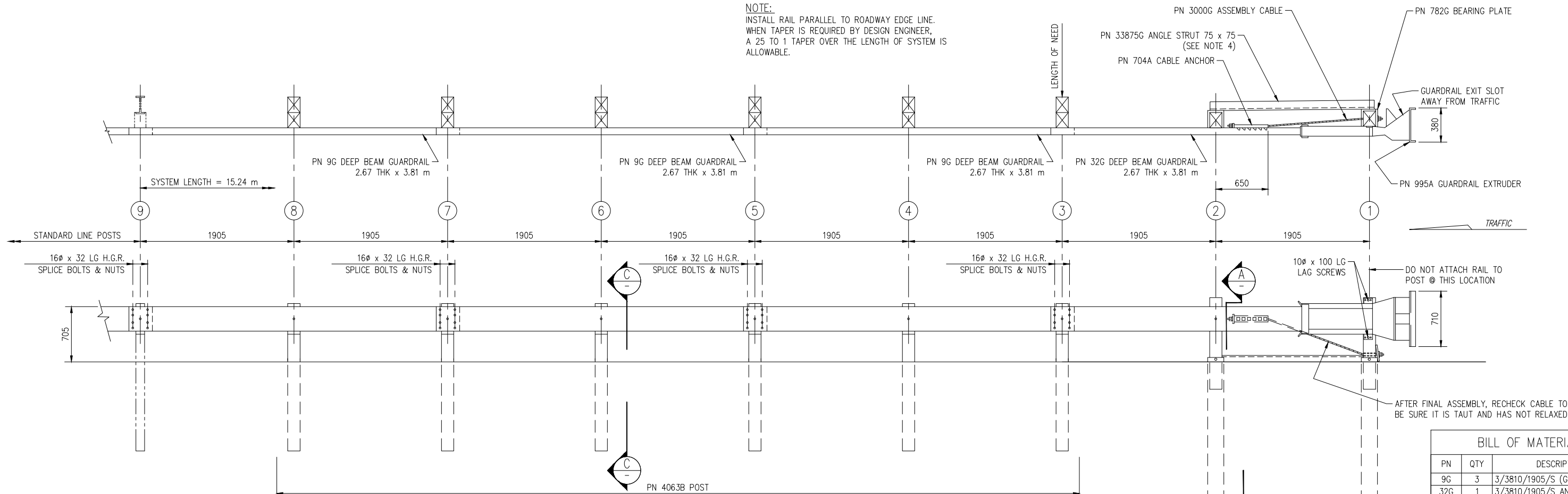
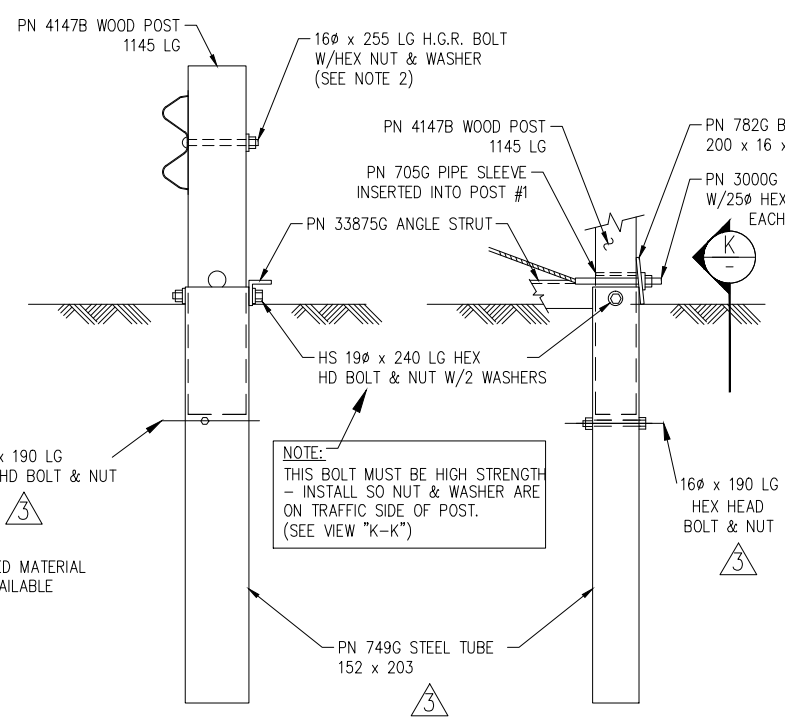

SECTION "A-A"  
(@ POST #2)

PARTIAL VIEW @ POST #1  
(DO NOT ATTACH GUARDRAIL TO POST)

- NOTES:
- 1.) DO NOT ATTACH GUARDRAIL TO POST # 1.
  - 2.) THE 16 FLAT WASHER IS USED UNDER THE NUT BEHIND THE POST ONLY. NO WASHER IS USED AT THE RAIL.
  - 3.) MANUFACTURER SUGGESTS CUSTOMER TO PROVIDE REFLECTORIZATION OF TERMINAL.
  - 4.) ANGLE STRUT MUST BE ATTACHED USING 19 DIA HIGH STRENGTH BOLTS.

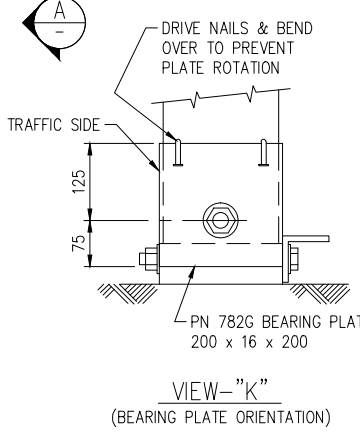
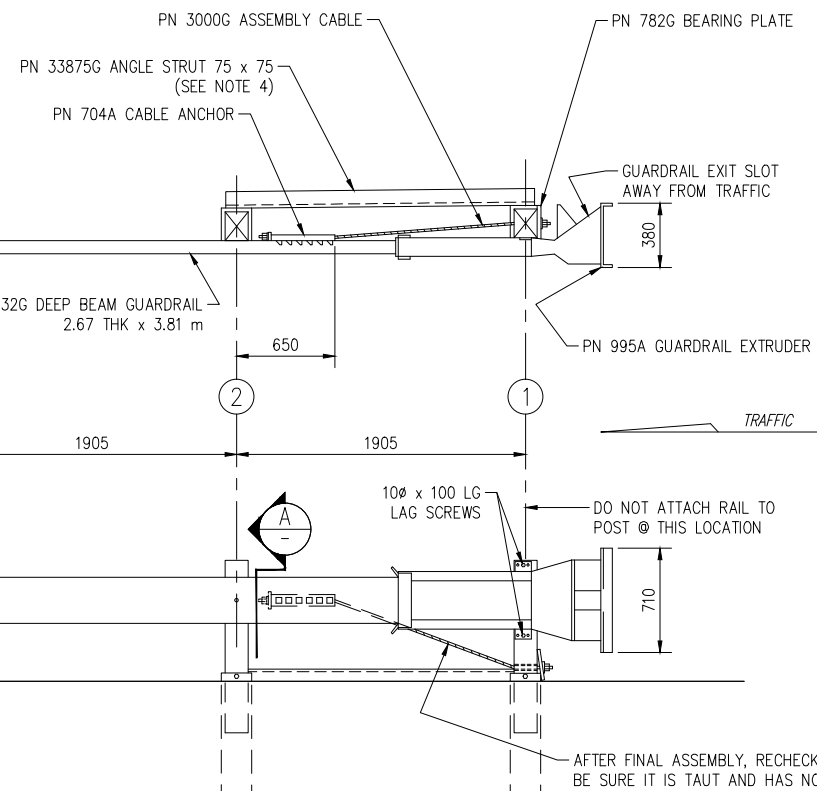

VIEW-"K"  
(BEARING PLATE ORIENTATION)

BILL OF MATERIAL		
PN	QTY	DESCRIPTION
9G	3	3/3810/1905/S (GUARDRAIL)
32G	1	3/3810/1905/S ANC (GUARDRAIL)
704A	1	CABLE ANCHOR BRACKET
705G	1	50 x 140 PIPE
749G	2	1830 TUBE SLEEVE
782G	1	16 x 200 x 200 BEARING PLATE
995A	1	ET-PLUS EXTRUDER
3000G	1	CABLE 19 x 1980
3300G	7	16 WASHER
3340G	41	16 HEX NUT
3360G	32	16φ x 32 SPLICE BOLT
3478G	2	16φ x 190 HEX HD BOLT
3500G	1	16φ x 255 POST BOLT
3580G	6	16φ x 455 POST BOLT
3700G	4	19 WASHER
3704G	2	19 HEX NUT
3900G	2	25 WASHER
3910G	2	25 HEX NUT
4063B	6	WD 1830 POST 150 x 200
4075B	6	WD BLOCK 356 x 150 x 200 DR
4147B	2	WD 1145 POST 140 x 190
4228G	2	10φ x 100 LAG SCREW
5148G	2	19φ x 240 HEX HD BOLT
33875G	1	ANGLE STRUT

METRIC

REV.	CHK'D	BY	DATE	REMARKS
3	B.T.	L.H.	4/18/07	ADDED 7 1/2" BOLTS @ POSTS 1 & 2; SWITCHED TUBES @ 1 & 2
2	B.T.	L.H.	8/25/06	ATTACHED G-RAIL TO POSTS #3, 5, 7; CHANGED TAPER NOTE
1		E.A.S.	10/24/01	UPDATED VIEWS & ADDED VIEW-"K"



ET-PLUS - 15.24 m  
WITH 3.81 m RAILS & 2 POST SLEEVES  
WITHOUT SOIL PLATE, HBA STRUT  
PLAN, ELEVATION & SECTION

TRINITY HIGHWAY PRODUCTS, LLC.  
2525 STEMMONS FREEWAY  
DALLAS, TX 75207

DRAWN	BT
CHECKED	
SCALE	N.T.S.
DATE	09/25/01
ENG. FILE #	SS334-01M
SHT.No.	E1 OF 1
DRAWING NO.	SS-334
REV.	3

This drawing and the information shown thereon is the sole property of TRINITY H.P., LLC. Neither the drawing nor such information is to be used for any purpose other than that for which it was specifically furnished by TRINITY H.P., LLC., nor is any reproduction authorized without written permission.